

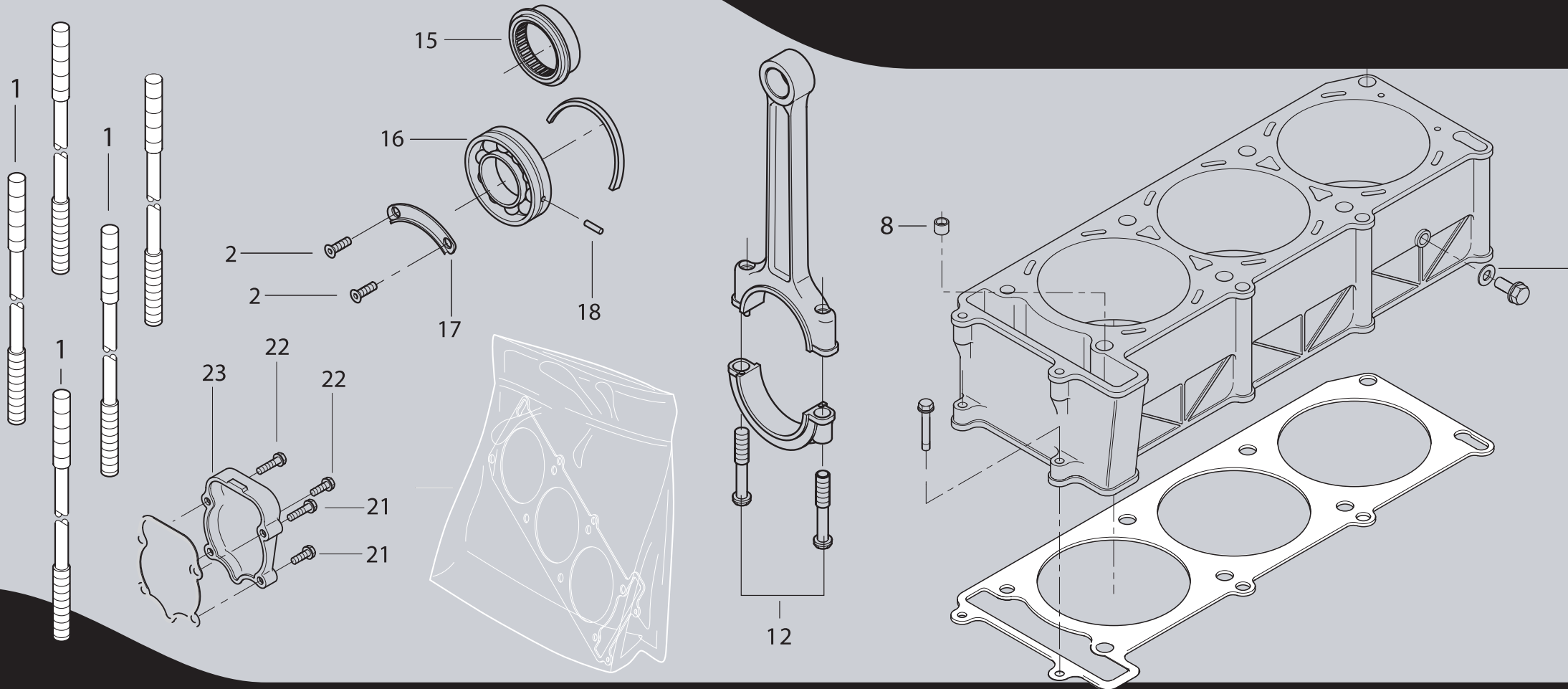

Pure Passion since 1911



aggiornamento
ver. 03 Aprile 2009



CATALOGO RICAMBI • SPARE PARTS CATALOGUE • CATALOGUE PIÉCES DETACHEES
ERSATZTEILKATALOG • CATALOGO PIEZAS DE REPUESTO

QUESTO CATALOGO SERVE PER RICHIEDERE CON ESATTEZZA LE PARTI DI RICAMBIO.

NELLE ORDINAZIONI INDICARE: IL NUMERO DEI CODICI DEI PARTICOLARI SEGUITO DALLA DESCRIZIONE E LA QUANTITÀ DESIDERATA.

LE INDICAZIONI CON LE FRECCIE SI RIFERISCONO AI LATI DEL VEICOLO RISPETTO AL SENSO DI MARCIA.

I DISEGNI DELLE PARTI DI RICAMBIO SONO SOLO INDICATIVI E NON RAPPRESENTANO IL PEZZO IN OGGETTO.

I DATI CONTENUTI IN QUESTO CATALOGO SONO INDICATIVI E POSSONO ESSERE SOGGETTI A MODIFICHE SENZA IMPEGNO DI PREAVVISO.

THE PRESENT SPARE PARTS ORDER EXACTLY THE RIGHT SPARE PARTS.

WHEN ORDERING SPECIFY: THE PART'S CODE NUMBER FOLLOWED BY ITS DESCRIPTION AND QUANTITY NEEDED.

REFERENCE WITH ARROWS APPLY TO THE VEHICLE IN TERMS OF ITS DIRECTION OF MOVEMENT.

SPARE PARTS DRAWINGS ARE GENERAL AND DO NOT REPRESENT THE PART.

THE CONTENTS OF THIS CATALOGUE ARE GENERAL AND CAN UNDERGO CHANGES WITHOUT PRIOR NOTICE.

CE CATALOGUE PERMET DE COMMANDER CORRECTEMENT LES PIÈCES DETACHEES.

LES COMMANDES DOIVENT ÊTRE PASSÉES EN INDIQUANT: LE NUMERO DE CODE DES PIÈCES DÉTACHÉES SUIVI DE LEUR DESCRIPTION ET QUANTITÉ DÉSIRÉE.

RÉFÉRENCE AVEC DES FLÈCHES SONT LES CÔTÉS DU VÉHICULE PAR RAPPORT AU SENS DE LA MARCHÉ.

LES PLANS DES PIÈCES DÉTACHÉES SONT FOURNIS SEULEMENT À TITRE INDICATIF ET NE REPRÉSENTENT PAS LA PIÈCE CONCERNÉE.

LES DONNÉES DE CE CATALOGUE SONT CITÉES SEULEMENT À TITRE INDICATIF ET PEUVENT ÊTRE L'OBJET DE MODIFICATIONS SANS AVIS PRÉALABLE.

DIESER ERSATZTEILKATALOG DIENT ZUR GENAUEN ANGABE DER TEILE BEI ERSATZTEILBESTELLUNGEN.

BEIERSATZBESTELLUNG IST FOLGENDES ANZUGEBEN: DIE BESTELLNUMMER DER ERSATZTEILE MIT DER ENTSPRECHENDEN BESCHREIBUNG UND GENAUE MENGE.

DIE ANGABEN MIT PFEILE BEZIEHEN SICH AUF DAS FAHRZEUG IN FAHRRICHTUNG.

DIE ZEICHNUNGEN DER ERSATZTEILE SIND NUR ALS HINWEISE GEDACHT UND STELLEN NICHT DAS BETROFFENE TEIL DAR.

BEI DEN IM KATALOG ANGEFÜHRTEN DATEN HANDELT ES SICH UM ANHALTSDATEN, DIE JEDERZEIT, OHNE VORANKÜNDIGUNG, GEÄNDERT WERDEN KÖNNEN.

EL PRESENTE CATÁLOGO SIRVE PARA PEDIR CON EXACTITUD LAS PARTES DE REPUESTO.

EN LOS PEDIDOS SE DEBE INDICAR: EL NÚMERO DE CÓDIGO DE LA PARTE Y A CONTINUACIÓN LA DESCRIPCIÓN Y CANTIDAD DESEADA.

LAS INDICACIONES CON LAS FLECHAS SE REFIEREN A LOS LADOS DEL VEHÍCULO RESPECTO DEL SENTIDO DE MARCHA.

LOS DISEÑOS DE LAS PARTES DE RECAMBIO SON SOLO INDICATIVOS Y NO REPRESENTAN LA PIEZA EN CUESTIÓN.

LOS DATOS CONTENIDOS EN EL PRESENTE CATÁLOGO SON INDICATIVOS Y PUEDEN MODIFICARSE SIN AVISO PREVIO.

3	00A	ATTREZZI SPECIALI	SPECIAL TOOLS	OUTILS SPECIAUX	SONDERWERKZEUGE	HERRAMENTAL ESPECIALES
5	001	DISTRIBUZIONE	TIMING	DISTRIBUTION	VENTILSTEUERUNG	DISTRIBUCIÓN
9	002	GRUPPO TESTA	CYLINDER HEAD	GROUPE CULASSE	ZYLINDERKOPFGRUPPE	GRUPO CULATA
15	003	CILINDRO PISTONI	CYLINDER PISTONS	CYLINDRE PISTONS	ZYLINDER KOLBEN	CILINDRO PISTONES
17	004	ASSIEME MANOVELLISMO	CRANK GEAR ASSEMBLY	ENSEMBLE BIELLISME	KURBELGETRIEBE KOMPLETT	JUNTO CINEMATISMO
19	005	COPPIA SEMICARTER	HALF CRANKCASES	DEMI-CARTERS	GEHÄUSEHÄLFTE	PAREJA SEMI-CARTER
21	006	ASSIEME CARTER	GUARD ASSEMBLY	ESEMBLE CARTERS	GEHÄUSE KOMPLETT	GRUPO CARTER
25	007	COPERCHI MOTORE	ENGINE COVERS	COUVERCLES MOTEUR	MOTOR DECKEL	TAPAS MOTOR
29	008	LUBRIFICAZIONE	LUBRIFICATION	LUBRIFICATION	SCHMERUNG	LUBRICACIÓN
31	009	POMPA ACQUA	WATER PUMP	POMPE EAU	WASSERPUMPE	BOMBA AGUA
35	010	FRIZIONE	CLUTCH	EMBRAYAGE	KUPPLUNG	EMBRAGUE
39	011	COMANDO CAMBIO	GEARCHANGE	COMMANDE BOÎTE A VITESSES	GANGSCHALTUNG	MANDO CAMBIO
43	012	CAMBIO	GEAR-BOX	BOÎTE A VITESSES	SCHALTUNG	CAMBIO
47	013	RADIATORE ACQUA	WATER RADIATOR	RADIATEUR D'EAU	WASSERKUEHLER	RADIATOR AGUA
51	014	CIRCUITO DI RAFFREDDAMENTO	COOLING CIRCUIT	CIRCUIT DE REFROIDISSEMENT	KÜHLREISLAUF	CIRCUITO DE REFRIGERADOR
53	015	ALIMENTAZIONE	FEEDING	ALIMENTACION	VERSORGUNG	ALIMENTACIÓN
57	016	ASPIRAZIONE	INTAKE	ASPIRATION	LUFTEINZUG	ASPIRACIÓN
61	017	GRUPPO SCARICO	EXHAUST SYSTEM	ECHAPPEMENT	AUSPUFFANLAGE	GRUPO ESCAPE
65	018	IMPIANTO ELETTRICO	ELECTRIC SYSTEM	INSTALLATION ELECTRIQUE	ELEKTRISCHE ANLAGE	SISTEMA ELECTRICO
67	019	AVVIAMENTO ELETTRICO	ELECTRIC STARTER	DEMARRAGE ELECTRONIQUE	ELEKTROSTARTER ANLASSER	PUESTA EN MARCHA ELECTRICA
69	020	STRUMENTAZIONE	INSTRUMENTATION	INSTRUMENTATION	INSTRUMENTEN-AUSRÜSTUNG	INSTRUMENTACIÓN
71	021	SENSORI	SENSORS	CAPTEURS	SENSOR	SENSORS
73	022	FANALI	HEAD-LIGHTS	PHARES	SCHEINWERFERS	FAROS
75	023	TELAIO	FRAME	CADRE	RAHMEN	CHASIS
77	024	CAVALLETTA	STAND	BEQUILLE	BOCK	CABALLETTE
79	025	FORCELLONE	SWINGARM	FOURCHE	SCHWINGE	BASCULANTE
81	026	ASSIEME FORCELLONE	SWING ARM ASSEMBLY	ENSEMBLE FOURCHE	GABEL KOMPLETT	GRUPO BASCULANTE
83	027	SOSPENSIONE POSTERIORE	REAR SUSPENSION	SUSPENSION ARRIÈRE	HINTERRADFEDERUNG	SUSPENSION TRASERA
85	028	CODONE	TAIL GUARD	CORPS DE SELLE	HECK	CUERPO ASIENTO
87	029	SCATOLA BATTERIA	BATTERY BOX	BOÎTE BATTERIE	BATTERIEGEHÄUSE	CAJA BATERÍA
91	030	PORTATARGA	NUMBER PLATE HOLDER	PORTE-PLAQUE	NUMMERSCHILDTAFEL	PORTA-MATRÍCULA
93	031	PEDANE ANTERIORI	FRONT FOOT PEG	REPOSE PIEDS AVANT	VORDERE FUSSRASTE	ESTRIBERAS DELANTERA
95	032	PEDANE POSTERIORI	REAR FOOT PEG	REPOSE PIEDS ARRIÈRE	HINTERE FUSSRASTE	ESTRIBERAS TRASERA
97	033	PARAFANGO ANTERIORE	FRONT MUDGUARD	GARDE-BOUE AVANT	VORDERES SCHUTZBLECH	GUARDABARROS DELANTERO
99	034	FORCELLA ANTERIORE	FRONT FORK	FOURCHE AVANT	TELEGABEL	HORQUILLA DELANTERA
101	035	MANUBRIO E COMANDI	HANDLEBAR AND CONTROLS	GUIDON ET COMANDES	LENKER UND STEUERORGANE	MANILLAR Y MANDOS
103	036	FRENO ANTERIORE	FRONT BRAKE	FREIN AVANT	VORD BREMSE	FRENO DELANTERO
105	037	FRENO POSTERIORE	REAR BRAKE	FREIN ARRIÈRE	HINTERBREMSE	FRENO TRASERO
107	038	RUOTA ANTERIORE	FRONT WHEEL	ROUE AVANT	VORDERRAD	RUEDA DELANTERA
109	039	RUOTA POSTERIORE	REAR WHEEL	ROUE ARRIÈRE	HINTERRAD	RUEDA TRASERA
111	040	CUPOLINO	HEADLIGHT FAIRING	CARÉNAGE	FAHRTWINDSCHUTZ	CÚPULA
113	041	CARENATURE	FAIRING	CARÉNAGE	SCHALE	BASTIDOR
115	042	SERBATOIO	FUEL TANK	RÉSEVOIR CARBURANT	KRAFTSTOFFTANK	DEPÓSITO GASOLINA
117	043	SERRATURE	LOCKS	SERRURE	SCHLOß	CERRADURES
119	044	PARAFANGO POSTERIORE	REAR MUDGUARD	GARDE-BOUE ARRIÈRE	HINTERE SCHUTZBLECH	GUARDABARROS TRASERO

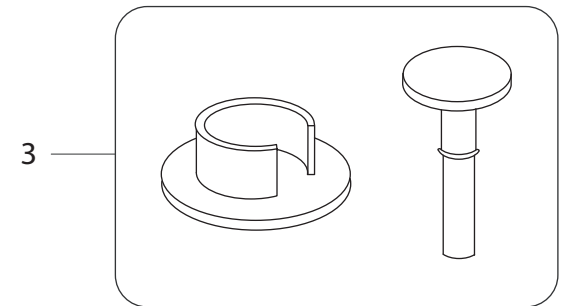
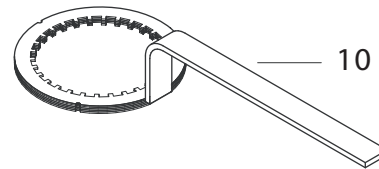
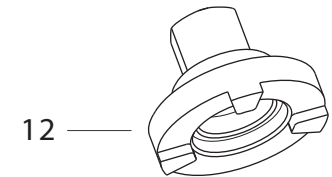
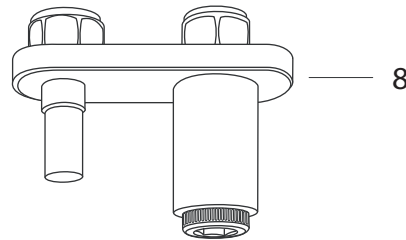
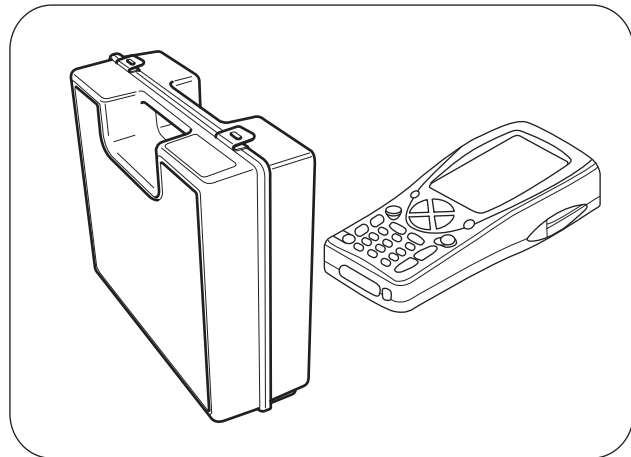
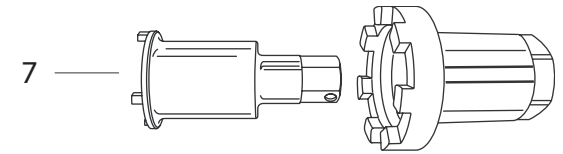
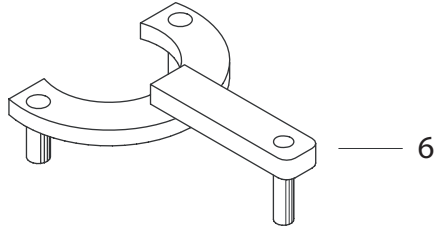
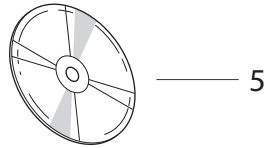
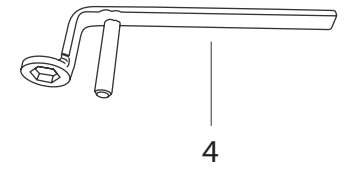
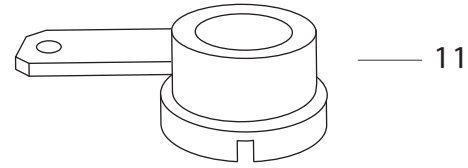
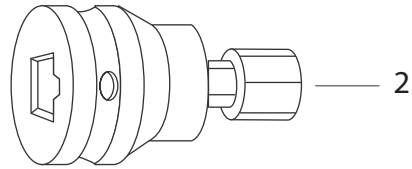
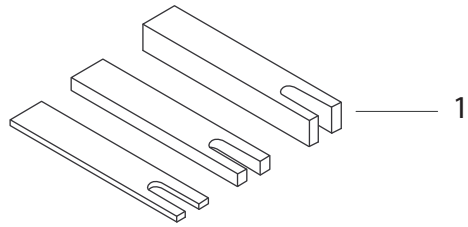

POS. NO. N. INDEX POS.	N. CODICE CODE NO. Nr. CODE ATRIKEL Nr. CODICO Nr.	DESCRIZIONE	DESCRIPTION	DESIGNATION	BEZEICHNUNG	DENOMINACION	NOTE NOTES MARKE NOTAS	Q.TA' Q.TY Q.TE M.GE C.AD	
1	R180197018000	DISTANZIALE MONTAGGIO CILINDRO	SPACER TO ASSEMBLY CYLINDER	ENTRETOISE AU CYLINDRE D'ASSEMBLÉE	DISTANZSTÜCK ZUM VERSAMMLUNG ZYLINDER	DISTANCIAL DEL CILINDRO		1	
2	R300097146000	CHIAVE MONTAGGIO TESTA DI STERZO	WRENCH MOUNTING STEERING HEAD	CLÉ DE TÊTE DE DIRECTION	SCHLÜSSEL FÜR MONTAGE GABELKOPF	LLAVE DEL MONTAJE DE LA TIJA SUPERIOR		1	
3	R180100143000	KIT SGANCIO RAPIDO	KIT RAPID REMOVE	KIT RAPIDE ENLEVER	KIT SCHNELL ENTFERNEN	KIT RÁPIDO QUITAR		1	
4	R180297130000	CHIAVE REGOLAZIONE SPINGIDISCO	WRENCH REGULATION PRESSURE PLATE	CLÉ DE POUSSÉ-DISQUE RÉGLEMENTAIRE	SCHLÜSSEL REGELUNG SCHEIBENDRÜCKER	LLAVE DE LA REGLA PLACA DE PRESIÓN		1	
5	R300094104000	MANUALE UTENTE	OWNER'S MANUAL	MANUEL UTILISATEUR	BENUTZER HANDBUCH	MANUAL USUARIO		1	
6	R180297048000	CHIAVE MONTAGGIO PIGNONE	WRENCH MOUNTING SPROCKET	CLÉ DE TÊTE DE PIGNON	SCHLÜSSEL FÜR MONTAGE RITZEL	LLAVE DEL MONTAJE DEL PIÑÓN		1	
7	R180297129000	CHIAVE MONTAGGIO GHIERA DI STERZO	WRENCH MOUNTING STEERING RING NUT	CLÉ DE TÊTE DE BAGUE DE DIRECTION	SCHLÜSSEL FÜR MONTAGE LENKUNGSZAPFEN	LLAVE DEL MONTAJE DEL ZUNCHO DE DIRECCIÓN		1	
8	R300097147000	CHIAVE TENSIONAMENTO CATENA TRASMISSIONE	WRENCH FOR TENSIONING TRANSMISSION CHAIN	CLÉ DE MISE EN TENSION CHAÎNE DE TRANSMISSION	SCHLÜSSEL FÜR SPANNGETRIEBE-KETTE	LLAVE PARA LA CADENA TENSORA DE LA TRANSMISIÓN		1	
9	R180197036000	STRUMENTO DIAGNOSI (IT)	DIAGNOSIS INSTRUMENT (IT)	INSTRUMENT DE DIAGNOSTIC (IT)	DIAGNOSE INSTRUMENT (IT)	INSTRUMENTO DE LA DIAGNOSIS (IT)		1	
9	R1801970360UK	STRUMENTO DIAGNOSI (UK)	DIAGNOSIS INSTRUMENT (UK)	INSTRUMENT DE DIAGNOSTIC (UK)	DIAGNOSE INSTRUMENT (UK)	INSTRUMENTO DE LA DIAGNOSIS (UK)		1	
9	R18019703600F	STRUMENTO DIAGNOSI (F)	DIAGNOSIS INSTRUMENT (F)	INSTRUMENT DE DIAGNOSTIC (F)	DIAGNOSE INSTRUMENT (F)	INSTRUMENTO DE LA DIAGNOSIS (F)		1	
9	R18019703600D	STRUMENTO DIAGNOSI (D)	DIAGNOSIS INSTRUMENT (D)	INSTRUMENT DE DIAGNOSTIC (D)	DIAGNOSE INSTRUMENT (D)	INSTRUMENTO DE LA DIAGNOSIS (D)		1	
9	R18019703600E	STRUMENTO DIAGNOSI (E)	DIAGNOSIS INSTRUMENT (E)	INSTRUMENT DE DIAGNOSTIC (E)	DIAGNOSE INSTRUMENT (E)	INSTRUMENTO DE LA DIAGNOSIS (E)		1	
10	R180297047000	CHIAVE FERMA CAMPANA TAMBURO FRIZIONE	WRENCH TO HOLD CLUCH HOUSING DRUM STEADY	CLÉ DE MANTEN TAMBOUR CLOCHE D'EMBTAYAGE	KUPPLUNGSGLOCKENSCHLÜSSEL	LLAVE SUJETA-TAMBOR CAJA EMBRAGUE		1	
11	R300097161000	CHIAVE ALTERNATORE	GENERATOR KEY	CLÉ ALTERNATEUR	DREHSTOMGENERATOR SCHLÜSSEL	LLAVE ALTERNADOR		1	
12	R300097162000	CHIAVE TAPPO FORCELLA	FORK CAP KEY	CLÉ BOUCHON FOURCHE	SCHLÜSSEL VERSCHLUß GABEL	LLAVE TAPÓN HORQUILLA		1	

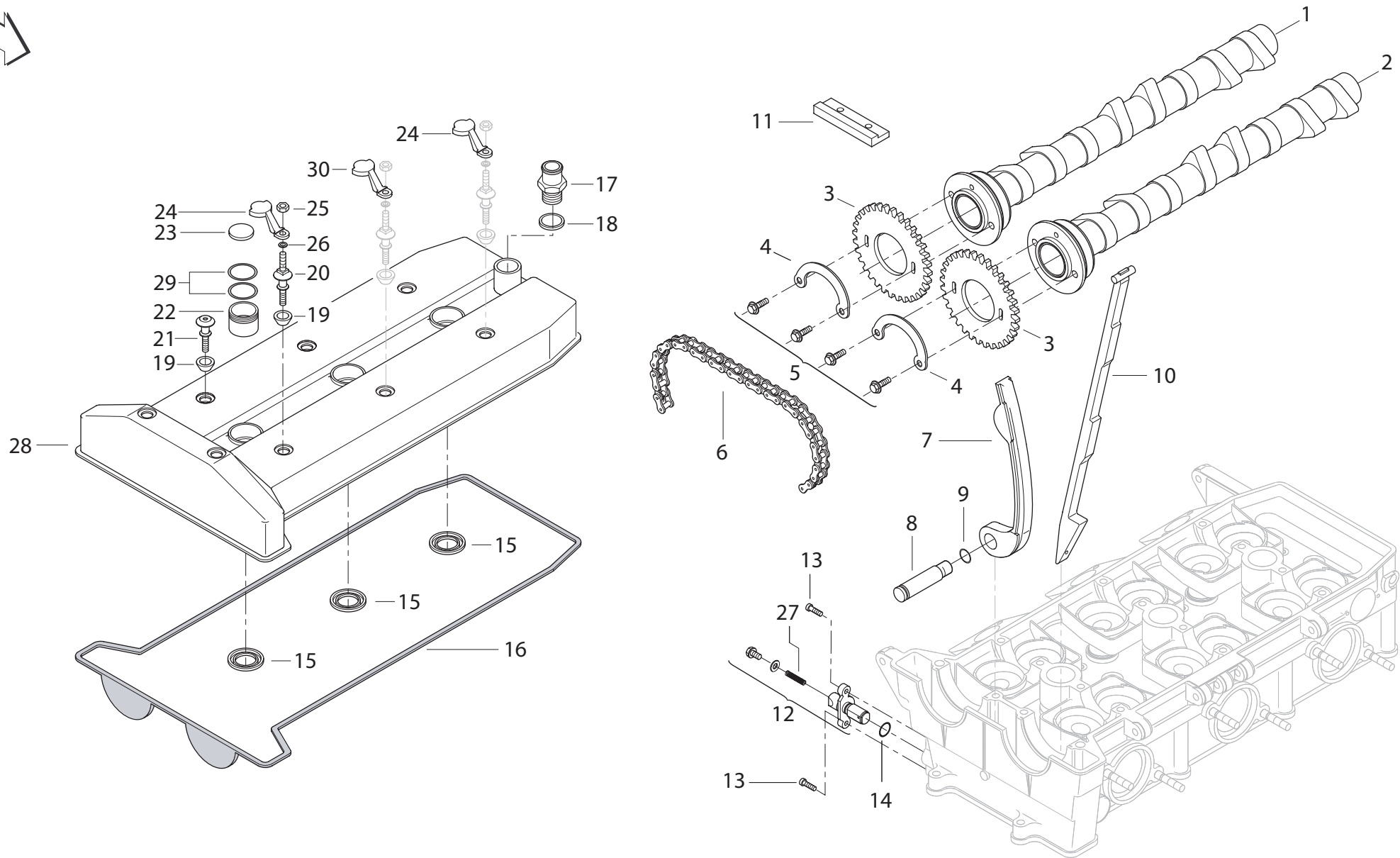

POS. NO. N. INDEX POS.	N. CODICE CODE NO. Nr. CODE ATRIKEL Nr. CODICO Nr.	DESCRIZIONE	DESCRIPTION	DESIGNATION	BEZEICHNUNG	DENOMINACION	NOTE NOTES MARKE NOTAS	Q.TA' Q.TY Q.TE M.GE C.AD	
1	R300017001000	ALBERO DISTRIBUZIONE ASPIRAZIONE	INTAKE CAMSHAFT	ARBRE DISTRIBUTION ASPIRATION	VERTEILERWELLE DER ANSAUGUNG	ARBOL DISTRIBUCIÓN ASPIRACIÓN		1	
2	R180217002000	ALBERO DISTRIBUZIONE SCARICO	EXHAUST CAMSHAFT	ARBRE DISTRIBUTION ÉCHAPPEMENT	VERTEILERWELLE AUSLAß	ARBOL DISTRIBUCIÓN DESCARGA		1	
3	R180217011000	INGRANAGGIO Z 34	GEAR Z 34	ENGRENAGE Z 34	ZAHNRAD Z 34	ENGRANAJE Z 34		2	
4	R180217012000	PIASTRINO SPECIALE	SPECIAL PLATE	PLAQUETTE SPÉCIALE	SPEZIALPLÄTTCHEN	LÁMINA ESPECIAL		2	
5	R15113281A	VITE	SCREW	VIS	SCHRAUBE	TORNILLO		4	
6	R15243031A	CATENA DISTRIBUZIONE	CHAIN DISTRIBUTION	DISTRIBUTION À CHAÎNE	KETTENVERTEILUNG	DISTRIBUCIÓN DE CADENA		1	
7	R15313141A	PATTINO CATENA	CHAIN SLIDER	PATIN CHAÎNE	KETTENGLEITSCHUH	PATÍN CADENA		1	
8	R15313201A	PERNO	PIN	PIVOT	ZAPFEN	PERNO		1	
9	R92850079M	ANELLO ELASTICO	SNAP RING	BAGUE ELASTIQUE	SPRENGRING	SEAGER		1	
10	R15313031A	PATTINO CATENA INFERIORE	LOWER CHAIN SLIDING SHOE	PATIN CHAÎNE INFÉRIEURE	UNTERER KETTENGLEITSCHUH	PATÍN CADENA INFERIOR		1	
11	R15313061A	PATTINO CATENA SUPERIORE	UPPER CHAIN SLIDING SHOE	PATIN CHAÎNE SUPÉRIEURE	OBERER KETTENGLEITSCHUH	PATÍN CADENA SUPERIOR		1	
12	R15343101A	TENDICATENA	CHAIN TENSIONER	TENDEUR DE CHAÎNE	KETTENSANNER	SENSOR DE CADENA		1	
13	R90750522B	VITE	SCREW	VIS	SCHRAUBE	TORNILLO		2	
14	R92850089M	GUARNIZIONE OR	O-RING	JOINT D'ÉTANCHÉITÉ	DICHTUNG OR	JUNTA OR		1	
15	R15513021A	GUARNIZIONE	GASKET	GARNITURE	DICHTUNG	JUNTA		3	
16	R15513011A	GUARNIZIONE COPERCHIO	COVER GASKET	GARNITURE COUVERCLE	DECKELDICHTUNG	JUNTA TAPA		1	
17	R180107002000	RACCORDO RAPIDO	QUICK-COUPLING UNION	RACCORD RAPIDE	STECKANSCHLUß	CONEXIÓN RÁPIDA		1	
18	R11043511A	ANELLO DI TENUTA	SEAL RING	BAGUE D'ÉTANCHÉITÉ	DICHTRING	ANILLO DE RETÉN		1	
19	R15513041A	GOMMINO	RUBBER PAD	JOINT EN CAOUTCHOUC	GUMMISTÜCK	JUNTA DE GOMA		2	
20	R15513061A	VITE SPECIALE	SPECIAL SCREW	VIS SPÉCIALE	SPEZIALSCHRAUBE	TORNILLO ESPECIAL		1	
21	R15513031A	VITE SPECIALE	SPECIAL SCREW	VIS SPÉCIALE	SPEZIALSCHRAUBE	TORNILLO ESPECIAL		1	
22	R500033007000	DISTANZIALE	SPACER	ENTRETOISE	DISTANZSTÜCK	DISTANCIAL		1	
23	R180133001000	GOMMINO	RUBBER PAD	JOINT EN CAOUTCHOUC	GUMMISTÜCK	JUNTA DE GOMA		1	
24	R500033002000	STAFFA	BRACKET	BRIDE	BÜGEL	SOPORTE		1	

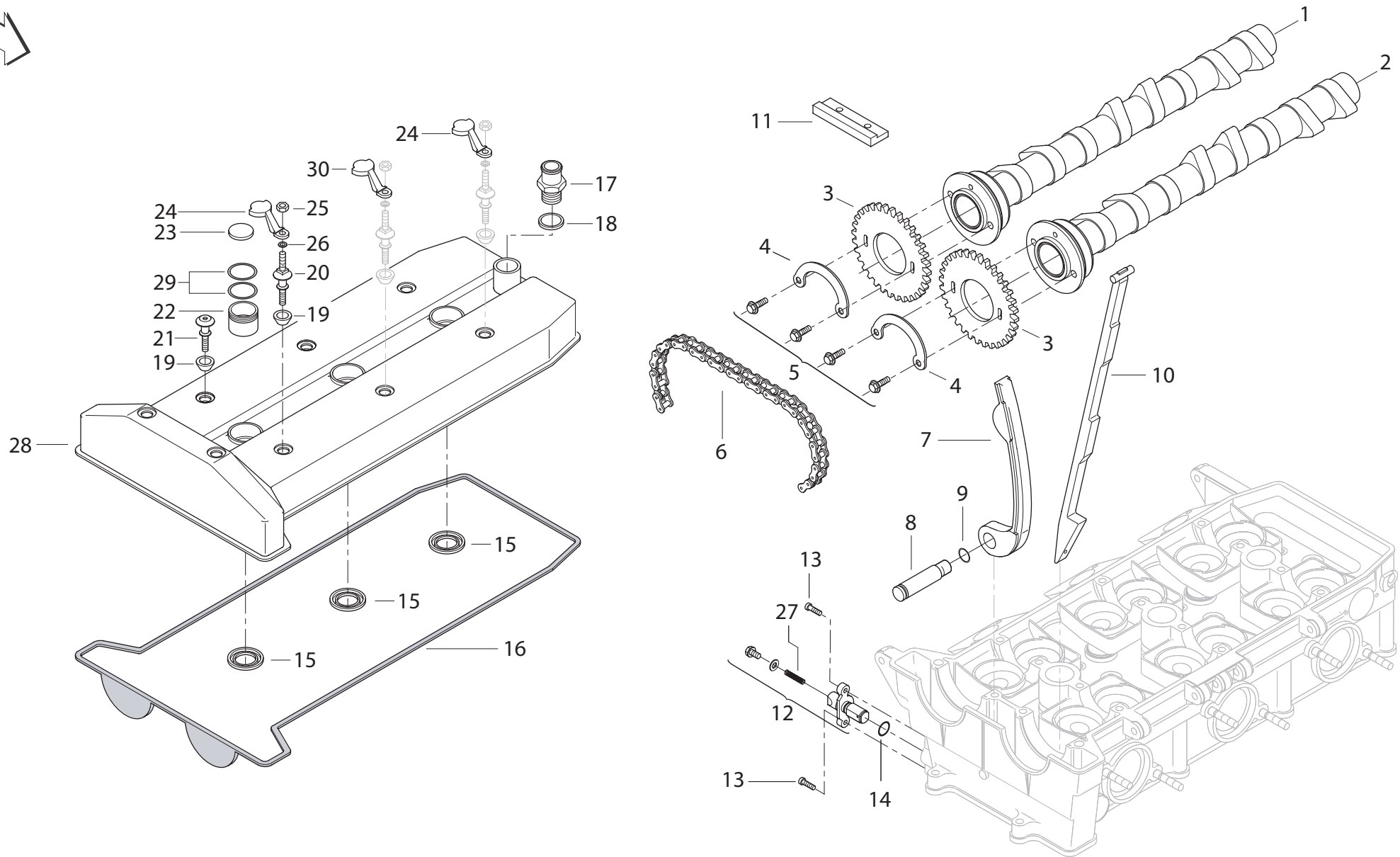

POS. NO. N. INDEX POS.	N. CODICE CODE NO. Nr. CODE ATRIKEL Nr. CODICO Nr.	DESCRIZIONE	DESCRIPTION	DESIGNATION	BEZEICHNUNG	DENOMINACION	NOTE NOTES MARKE NOTAS	Q.TA' Q.TY Q.TE M.GE C.AD	
25	R18243281A	DADO	NUT	ECROU	MUTTER	TUERCA		1	
26	R92751632B	RONDELLA	WASHER	RONDELLE	UNTERLEGSCHIEBE	ARANDELA		1	
27	R300018005000	MOLLA	SPRING	RESSORT	FEDER	MUELLE		1	
28	R1802010060CE	COPERCHIO DISTRIBUZIONE	CAMSHAFT COVER	COUVERCLE D'ARBRE Á CAMES	DECKELVERTEILER	CADENA DISTRIBUCIÓN		1	
29	R92850339M	GUARNIZIONE OR	O-RING	JOINT D'ÉTANCHÉITÉ	DICHTUNG OR	JUNTA OR		2	
30	R500033014000	STAFFA	BRACKET	BRIDE	BÜGEL	SOPORTE		1	

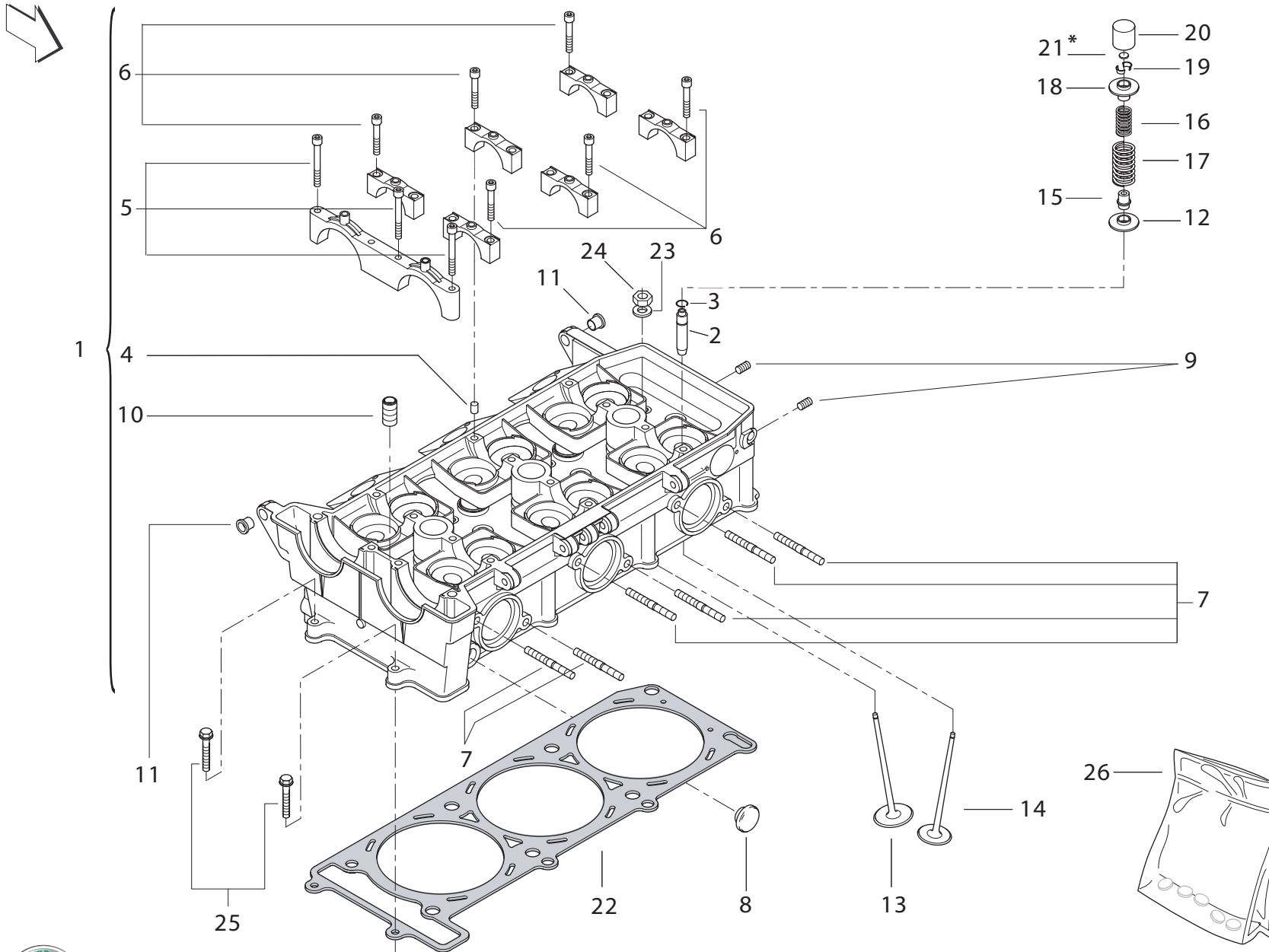

MISURA PASTIGLIA VALVOLE VALVES PAD MEASURE MESURE PASTILLE MASS PASTILLE VENTIL MEDIDA PASTILLA VÁLVULAS	
Codice Code Code Code Codice	
R14214641A	2,8 mm
R14214631A	2,775 mm
R14214621A	2,75 mm
R14214611A	2,725 mm
R14214601A	2,7 mm
R14214591A	2,675 mm
R14214581A	2,65 mm
R14214571A	2,625 mm
R14214561A	2,6 mm
R14214551A	2,575 mm
R14214541A	2,55 mm
R14214531A	2,525 mm
R14214521A	2,5 mm
R14214511A	2,475 mm
R14214501A	2,45 mm
R14214491A	2,425 mm
R14214481A	2,4 mm
R14214471A	2,375 mm
R14214461A	2,35 mm
R14214451A	2,325 mm
R14214441A	2,3 mm
R14214431A	2,275 mm
R14214421A	2,25 mm
R14214411A	2,225 mm
R14214401A	2,2 mm
R14214391A	2,175 mm
R14214381A	2,15 mm
R14214371A	2,275 mm
R14214361A	2,25 mm
R14214321A	2,000 mm
R14214331A	2,025 mm
R14214341A	2,050 mm
R14214351A	2,075 mm
R14214301A	1,950 mm
R14214311A	1,975 mm



POS. NO. N. INDEX POS.	N. CODICE CODE NO. Nr. CODE ATRIKEL Nr. CODICO Nr.	DESCRIZIONE	DESCRIPTION	DESIGNATION	BEZEICHNUNG	DENOMINACION	NOTE NOTES MARKE NOTAS	Q.TA' Q.TY Q.TE M.GE C.AD	
1	R1802130011CE	TESTA CILINDRO	CYLINDER HEAD	CYLINDRE TÊTE	ZYLINDERKOPFBEFESTIGUNG	CULATA CILINDRO		1	
2	R14013051A	GUIDA VALVOLA	VALVE GUIDE	GUIDE SOUPAPE	VENTILFÜHRUNG	GUÍA VÁLVULA		1	
3	R14013061A	ANELLINO DI FERMO	CHECK RING	BAGUE D'ARRÊT	SICHERUNGSRING	ANILLO DE BLOQUEO		1	
4	R16313361A	BUSSOLA	BUSH	DOUILLE	BUCHSE	CASQUILLO		1	
5	R90250740C	VITE	SCREW	VIS	SCHRAUBE	TORNILLO		3	
6	R90250720C	VITE	SCREW	VIS	SCHRAUBE	TORNILLO		6	
7	R14013111A	PRIGIONIERO	STUD BOLT	GOUJON	STIFTSCHRAUBE	TORNILLO SIN FIN		6	
8	R14043131A	TAPPO	CAP	BOUCHON	VERSCHLUß	TAPÓN		1	
9	R14043141A	TAPPO FILETTATO	THREADED CAP	BOUCHON FILETÉE	GEWINDE VERSCHLUß	TAPÓN FILETEADO		2	
10	R11043531A	TAPPO FILETTATO	THREADED CAP	BOUCHON FILETÉE	GEWINDE VERSCHLUß	TAPÓN FILETEADO		1	
11	R21213861A	BOCCOLA	BUSH	DOUILLE	BUCHSE	CASQUILLO		2	
12	R180217013000	SCODELLINO INFERIORE	LOWER CUP	COUPELLE D'APPUI	UNTERER BECHER	TAZA INFERIOR		1	
13	R180236121000	VALVOLA ASPIRAZIONE	INTAKE VALVE	SOUPAPE ADMISSION	EINLAßVENTIL	VÁLVULA DE ASPIRACIÓN		1	
14	R180236122000	VALVOLA DI SCARICO	EXHAUST VALVE	SOUPAPE D'ÉCHAPPEMENT	AUSLABVENTIL	VÁLVULA DE DESGARGA		1	
15	R14043121A	GOMMINO VALVOLA	RUBBER PAD VALVE	JOINT EN CAOUTCHOUC SOUPAPE	GOMMISTÜCK AUSLA	JUNTA DE GOMA VÁLVULA		1	
16	R14213051A	MOLLA INTERNA	INNER SPRING	RESSORT INTERNE	INNERE FEDER	MUELLE INTERIOR		1	
17	R14213041A	MOLLA ESTERNA	OUTER SPRING	RESSORT EXTERNE	ÄÜßERE FEDER	MUELLE EXTERIOR		1	
18	R180236123000	SCODELLINO SUPERIORE	UPPER CUP	COUPELLE SUPERIEURE	OBERER BECHER	TAZA SUPERIOR		1	
19	R180236124000	SEMICONO	HALF CONE	DEMICONE	HALBKEGEL	SEMICONO		1	
20	R14213001B	BICCHIERINO	LIFTER BUCKET	POUSSOIR	BECHER	COPITA		1	
21	R14214641A	PASTIGLIA VALVOLA 2.8 mm	VALVE PAD	PASTILLE SOUPAPE	PASTILLEVENTIL	PASTILLA VÁLVULA		1	
21	R14214631A	PASTIGLIA VALVOLA 2.775mm	VALVE PAD	PASTILLE SOUPAPE	PASTILLEVENTIL	PASTILLA VÁLVULA		1	
21	R14214621A	PASTIGLIA VALVOLA 2.75mm	VALVE PAD	PASTILLE SOUPAPE	PASTILLEVENTIL	PASTILLA VÁLVULA		1	
21	R14214611A	PASTIGLIA VALVOLA 2.725 mm	VALVE PAD	PASTILLE SOUPAPE	PASTILLEVENTIL	PASTILLA VÁLVULA		1	

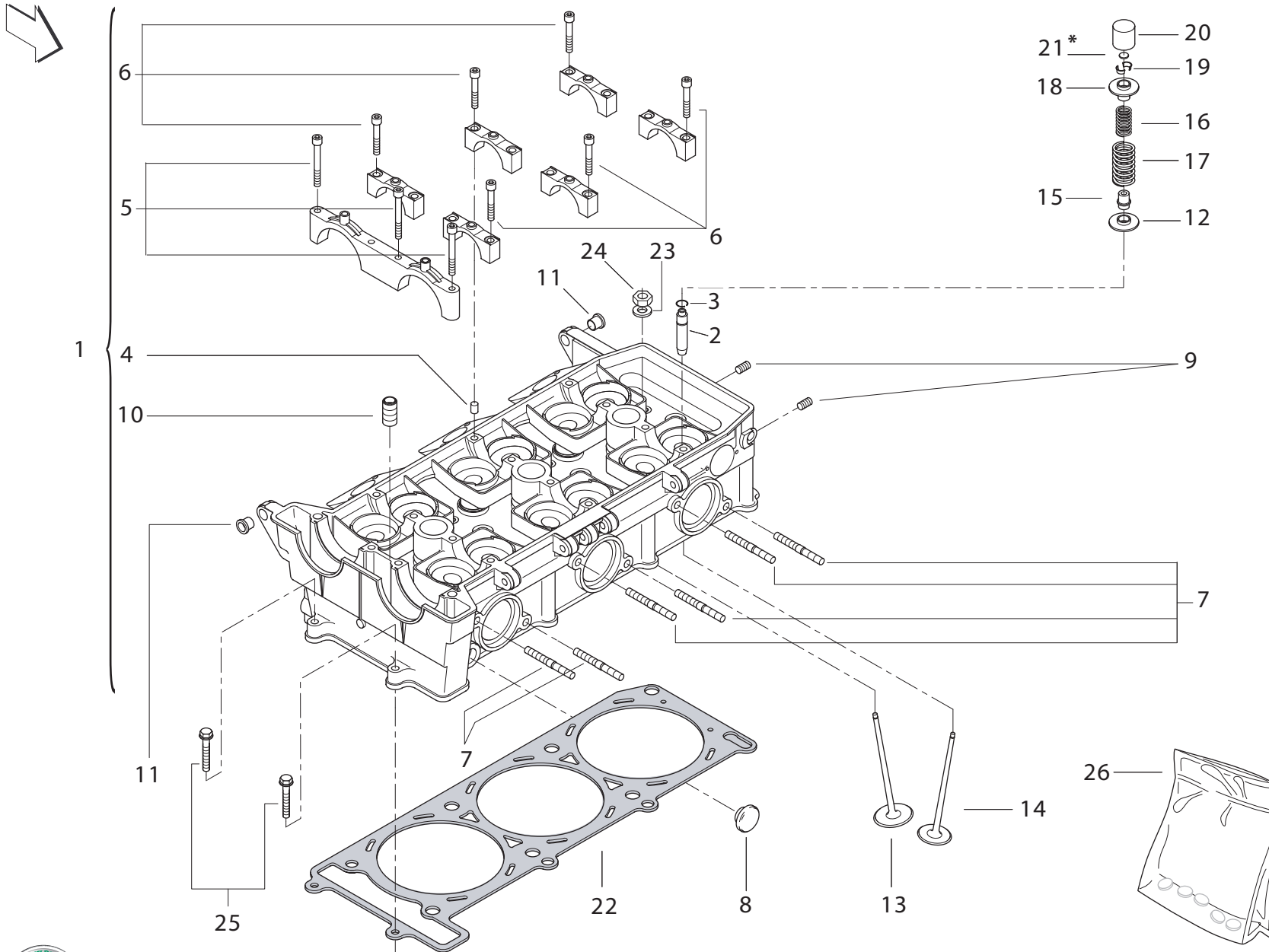

MISURA PASTIGLIA VALVOLE
VALVES PAD MEASURE
MESURE PASTILLE
MASS PASTILLE VENTIL
MEDIDA PASTILLA VÁLVULAS

Codice
Code
Code
Code
Codice

R14214641A	2,8 mm
R14214631A	2,775 mm
R14214621A	2,75 mm
R14214611A	2,725 mm
R14214601A	2,7 mm
R14214591A	2,675 mm
R14214581A	2,65 mm
R14214571A	2,625 mm
R14214561A	2,6 mm
R14214551A	2,575 mm
R14214541A	2,55 mm
R14214531A	2,525 mm
R14214521A	2,5 mm
R14214511A	2,475 mm
R14214501A	2,45 mm
R14214491A	2,425 mm
R14214481A	2,4 mm
R14214471A	2,375 mm
R14214461A	2,35 mm
R14214451A	2,325 mm
R14214441A	2,3 mm
R14214431A	2,275 mm
R14214421A	2,25 mm
R14214411A	2,225 mm
R14214401A	2,2 mm
R14214391A	2,175 mm
R14214381A	2,15 mm
R14214371A	2,275 mm
R14214361A	2,25 mm
R14214321A	2,000 mm
R14214331A	2,025 mm
R14214341A	2,050 mm
R14214351A	2,075 mm
R14214301A	1,950 mm
R14214311A	1,975 mm

POS. NO. N. INDEX POS.	N. CODICE CODE NO. Nr. CODE ATRIKEL Nr. CODICO Nr.	DESCRIZIONE	DESCRIPTION	DESIGNATION	BEZEICHNUNG	DENOMINACION	NOTE NOTES MARKE NOTAS	Q.TA' Q.TY Q.TE M.GE C.AD	
21	R14214601A	PASTIGLIA VALVOLA 2.7 mm	VALVE PAD	PASTILLE SOUPAPE	PASTILLEVENTIL	PASTILLA VÁLVULA		1	
21	R14214591A	PASTIGLIA VALVOLA 2.675 mm	VALVE PAD	PASTILLE SOUPAPE	PASTILLEVENTIL	PASTILLA VÁLVULA		1	
21	R14214581A	PASTIGLIA VALVOLA 2.65 mm	VALVE PAD	PASTILLE SOUPAPE	PASTILLEVENTIL	PASTILLA VÁLVULA		1	
21	R14214571A	PASTIGLIA VALVOLA 2.625 mm	VALVE PAD	PASTILLE SOUPAPE	PASTILLEVENTIL	PASTILLA VÁLVULA		1	
21	R14214561A	PASTIGLIA VALVOLA 2.6 mm	VALVE PAD	PASTILLE SOUPAPE	PASTILLEVENTIL	PASTILLA VÁLVULA		1	
21	R14214551A	PASTIGLIA VALVOLA 2.575 mm	VALVE PAD	PASTILLE SOUPAPE	PASTILLEVENTIL	PASTILLA VÁLVULA		1	
21	R14214541A	PASTIGLIA VALVOLA 2.55 mm	VALVE PAD	PASTILLE SOUPAPE	PASTILLEVENTIL	PASTILLA VÁLVULA		1	
21	R14214531A	PASTIGLIA VALVOLA 2.525 mm	VALVE PAD	PASTILLE SOUPAPE	PASTILLEVENTIL	PASTILLA VÁLVULA		1	
21	R14214521A	PASTIGLIA VALVOLA 2.5 mm	VALVE PAD	PASTILLE SOUPAPE	PASTILLEVENTIL	PASTILLA VÁLVULA		1	
21	R14214511A	PASTIGLIA VALVOLA 2.475 mm	VALVE PAD	PASTILLE SOUPAPE	PASTILLEVENTIL	PASTILLA VÁLVULA		1	
21	R14214501A	PASTIGLIA VALVOLA 2.45 mm	VALVE PAD	PASTILLE SOUPAPE	PASTILLEVENTIL	PASTILLA VÁLVULA		1	
21	R14214491A	PASTIGLIA VALVOLA 2.425 mm	VALVE PAD	PASTILLE SOUPAPE	PASTILLEVENTIL	PASTILLA VÁLVULA		1	
21	R14214481A	PASTIGLIA VALVOLA 2.4 mm	VALVE PAD	PASTILLE SOUPAPE	PASTILLEVENTIL	PASTILLA VÁLVULA		1	
21	R14214471A	PASTIGLIA VALVOLA 2.375 mm	VALVE PAD	PASTILLE SOUPAPE	PASTILLEVENTIL	PASTILLA VÁLVULA		1	
21	R14214461A	PASTIGLIA VALVOLA 2.35 mm	VALVE PAD	PASTILLE SOUPAPE	PASTILLEVENTIL	PASTILLA VÁLVULA		1	
21	R14214451A	PASTIGLIA VALVOLA 2.325 mm	VALVE PAD	PASTILLE SOUPAPE	PASTILLEVENTIL	PASTILLA VÁLVULA		1	
21	R14214441A	PASTIGLIA VALVOLA 2.3 mm	VALVE PAD	PASTILLE SOUPAPE	PASTILLEVENTIL	PASTILLA VÁLVULA		1	
21	R14214431A	PASTIGLIA VALVOLA 2.275 mm	VALVE PAD	PASTILLE SOUPAPE	PASTILLEVENTIL	PASTILLA VÁLVULA		1	
21	R14214421A	PASTIGLIA VALVOLA 2.25 mm	VALVE PAD	PASTILLE SOUPAPE	PASTILLEVENTIL	PASTILLA VÁLVULA		1	
21	R14214411A	PASTIGLIA VALVOLA 2.225 mm	VALVE PAD	PASTILLE SOUPAPE	PASTILLEVENTIL	PASTILLA VÁLVULA		1	
21	R14214401A	PASTIGLIA VALVOLA 2.2 mm	VALVE PAD	PASTILLE SOUPAPE	PASTILLEVENTIL	PASTILLA VÁLVULA		1	
21	R14214391A	PASTIGLIA VALVOLA 2.175 mm	VALVE PAD	PASTILLE SOUPAPE	PASTILLEVENTIL	PASTILLA VÁLVULA		1	
21	R14214381A	PASTIGLIA VALVOLA 2.15 mm	VALVE PAD	PASTILLE SOUPAPE	PASTILLEVENTIL	PASTILLA VÁLVULA		1	
21	R14214371A	PASTIGLIA VALVOLA 2.125 mm	VALVE PAD	PASTILLE SOUPAPE	PASTILLEVENTIL	PASTILLA VÁLVULA		1	

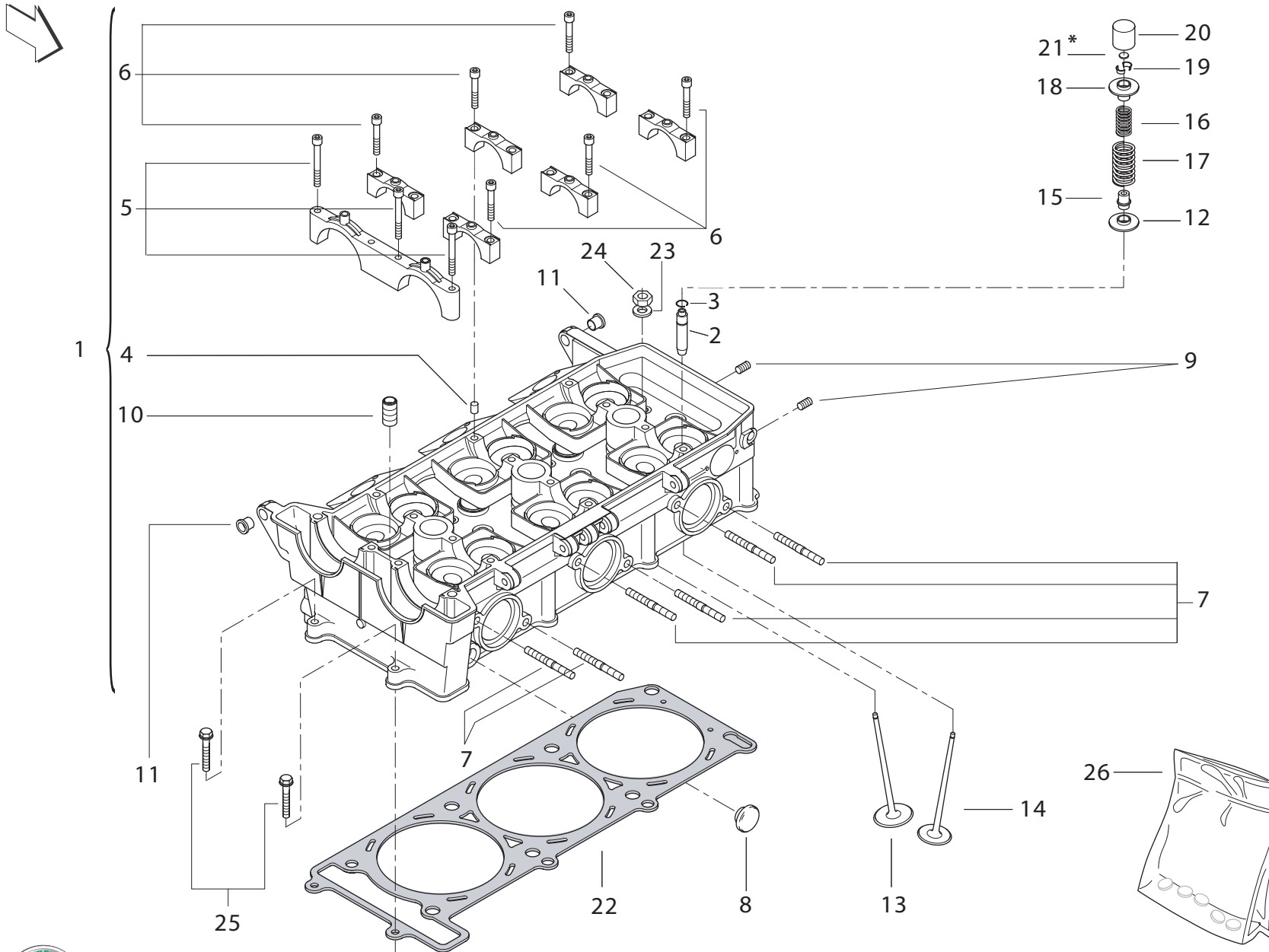

MISURA PASTIGLIA VALVOLE
VALVES PAD MEASURE
MESURE PASTILLE
MASS PASTILLE VENTIL
MEDIDA PASTILLA VÁLVULAS

Codice
Code
Code
Code
Code
Codice

R14214641A	2,8 mm
R14214631A	2,775 mm
R14214621A	2,75 mm
R14214611A	2,725 mm
R14214601A	2,7 mm
R14214591A	2,675 mm
R14214581A	2,65 mm
R14214571A	2,625 mm
R14214561A	2,6 mm
R14214551A	2,575 mm
R14214541A	2,55 mm
R14214531A	2,525 mm
R14214521A	2,5 mm
R14214511A	2,475 mm
R14214501A	2,45 mm
R14214491A	2,425 mm
R14214481A	2,4 mm
R14214471A	2,375 mm
R14214461A	2,35 mm
R14214451A	2,325 mm
R14214441A	2,3 mm
R14214431A	2,275 mm
R14214421A	2,25 mm
R14214411A	2,225 mm
R14214401A	2,2 mm
R14214391A	2,175 mm
R14214381A	2,15 mm
R14214371A	2,275 mm
R14214361A	2,25 mm
R14214321A	2,000 mm
R14214331A	2,025 mm
R14214341A	2,050 mm
R14214351A	2,075 mm
R14214301A	1,950 mm
R14214311A	1,975 mm

POS. NO. N. INDEX POS.	N. CODICE CODE NO. Nr. CODE ATRIKEL Nr. CODICO Nr.	DESCRIZIONE	DESCRIPTION	DESIGNATION	BEZEICHNUNG	DENOMINACION	NOTE NOTES MARKE NOTAS	Q.TA' Q.TY Q.TE M.GE C.AD	
21	R14214361A	PASTIGLIA VALVOLA 2.1 mm	VALVE PAD	PASTILLE SOUPAPE	PASTILLEVENTIL	PASTILLA VÁLVULA		1	
21	R14214491A	PASTIGLIA VALVOLA 2.425 mm	VALVE PAD	PASTILLE SOUPAPE	PASTILLEVENTIL	PASTILLA VÁLVULA		1	
21	R14214321A	PASTIGLIA VALVOLA 2.000 mm	VALVE PAD	PASTILLE SOUPAPE	PASTILLEVENTIL	PASTILLA VÁLVULA		1	
21	R14214331A	PASTIGLIA VALVOLA 2.025 mm	VALVE PAD	PASTILLE SOUPAPE	PASTILLEVENTIL	PASTILLA VÁLVULA		1	
21	R14214341A	PASTIGLIA VALVOLA 2.050 mm	VALVE PAD	PASTILLE SOUPAPE	PASTILLEVENTIL	PASTILLA VÁLVULA		1	
21	R14214351A	PASTIGLIA VALVOLA 2.075 mm	VALVE PAD	PASTILLE SOUPAPE	PASTILLEVENTIL	PASTILLA VÁLVULA		1	
21	R14214301A	PASTIGLIA VALVOLA 1.950 mm	VALVE PAD	PASTILLE SOUPAPE	PASTILLEVENTIL	PASTILLA VÁLVULA		1	
21	R14214311A	PASTIGLIA VALVOLA 1.975 mm	VALVE PAD	PASTILLE SOUPAPE	PASTILLEVENTIL	PASTILLA VÁLVULA		1	
22	R14113111A	GUARNIZIONE	GASKET	GARNITURE	DICHTUNG	JUNTA		1	
23	R14413011A	RONDELLA	WASHER	RONDELLE	UNTERLEGSCHIEBE	ARANDELA		1	
24	R14413031A	DADO	NUT	ECROU	MUTTER	TUERCA		1	
25	R90750712B	VITE	SCREW	VIS	SCHRAUBE	TORNILLO		2	
26	R300000183000	KIT REVISIONE PASTIGLIE VALVOLE	KIT VALVES PAD	KIT PASTILLE SOUPAPE	KIT PASTILLEVENTIL	KIT PASTILLE VÁLVULA		1	

CILINDRO PISTONI



CILINDRO PISTONI



CYLINDER PISTONS



CYLINDRE PISTONS



ZYLINDER KOLBEN



CILINDRO PISTONES

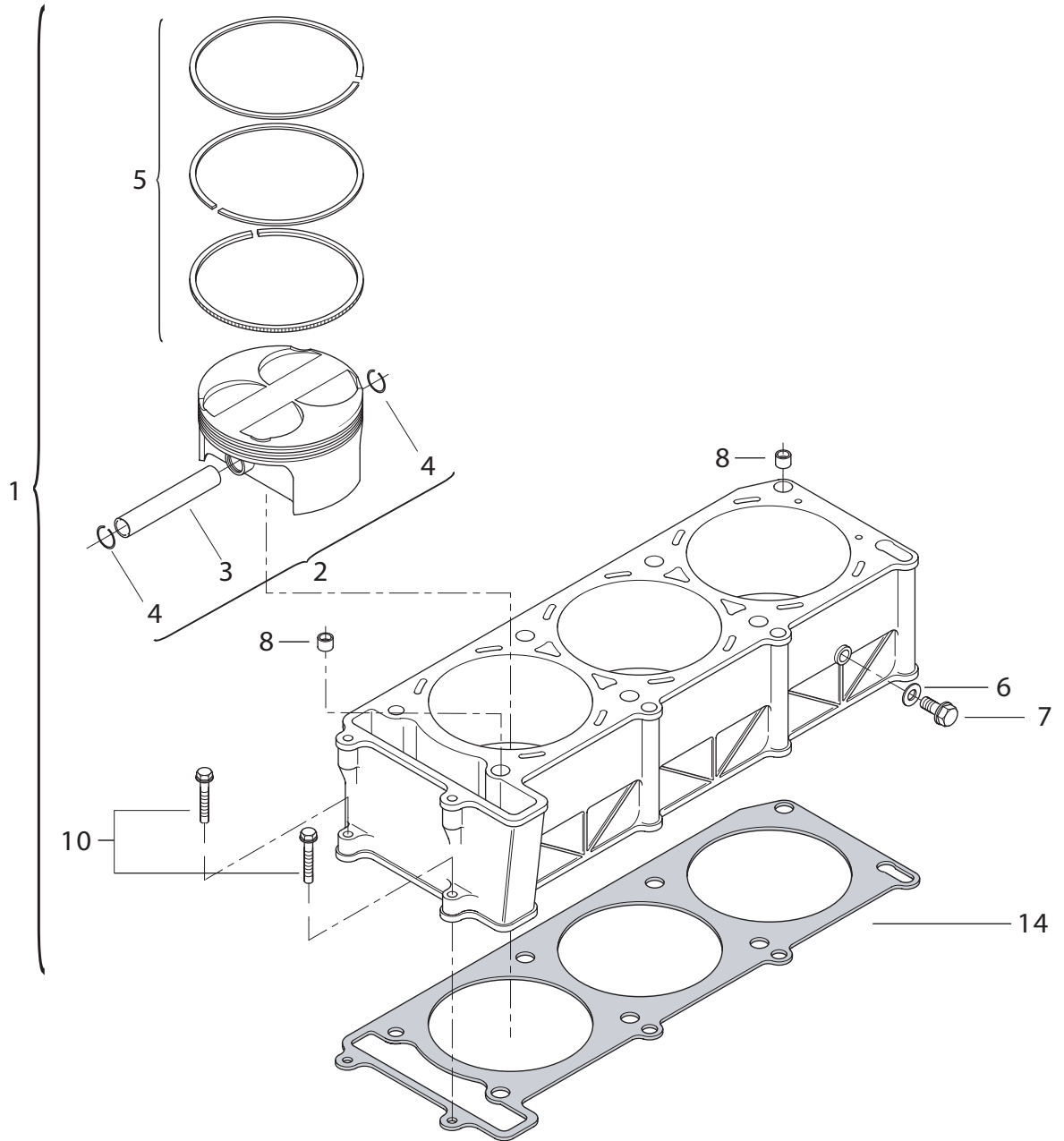
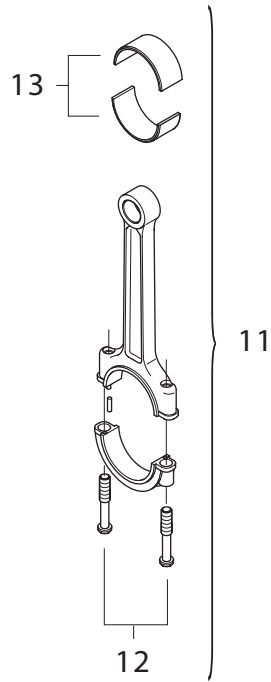
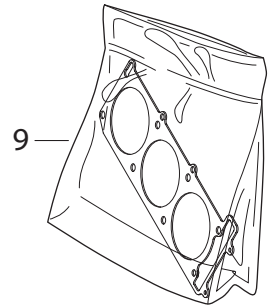

POS. NO. N. INDEX POS.	N. CODICE CODE NO. Nr. CODE ATRIKEL Nr. CODICO Nr.	DESCRIZIONE	DESCRIPTION	DESIGNATION	BEZEICHUNG	DENOMINACION	NOTE NOTES NOTES MARKE NOTAS	Q.TA' Q.TY Q.TE M.GE C.AD	
1	R300000168000	CILINDRO COMPLETO	COMPLETE CYLINDER	CYLINDRE COMPLET	ZYLINDER KOMPLET	CILINDRO COMPLETO		1	
2	R300011002000	PISTONE COMPLETO "B"	COMPLETE PISTON "B"	PISTON COMPLET "B"	KOMPLETTER KOLBEN "B"	PISTÓN COMPLETO "B"		1	
2	R300011005000	PISTONE COMPLETO "A"	COMPLETE PISTON "A"	PISTON COMPLET "A"	KOMPLETTER KOLBEN "A"	PISTÓN COMPLETO "A"		1	
2	R300011006000	PISTONE COMPLETO "C"	COMPLETE PISTON "C"	PISTON COMPLET "C"	KOMPLETTER KOLBEN "C"	PISTÓN COMPLETO "C"		1	
3	R13213011A	SPINOTTO PER PISTONE	PISTON PIN	AXE DE PISTON	KOLBENBOLZEN	BULÓN		1	
4	R13213021A	ANELLO ELASTICO FERMA SPINOTTO	PISTON PIN CIRCLIP	BAGUE ÉLASTIQUE BLOQUE-AXE	SPRENGRING ZUR BOLZENFESTSTELLUNG	ANILLO ELÁSTICO BLOQUEA-CLAVIJA		2	
5	R180100133000	SERIE SEGMENTI PISTONE	PISTON RINGS SET	ETUI SEGMENTS	BEUTEL MIT KOLBENRINGEN	SERIE DE SEGMENTOS		1	
6	R17143231A	RONDELLA	WASHER	RONDELLE	UNTERLEGSCHIEBE	ARANDELA		1	
7	R90750632B	VITE	SCREW	VIS	SCHRAUBE	TORNILLO		1	
8	R14013151A	BOCCOLA	BUSH	DOUILLE	BUCHSE	CASQUILLO		2	
9	R310000077000	SERIE GUARNIZIONI CILINDRO-TESTA	HEAD-CYLINDER GASKETS SET	ETUI GARNITURES CYLINDRE-TÊTE	BEUTEL DICHTUNG ZYLINDER-KOPF	SERIE JUNTAS CILINDRO-CULATA		1	
10	R90750712B	VITE	SCREW	VIS	SCHRAUBE	TORNILLO		2	
11	R180200164000	BIELLA COMPLETA	COMPLETE CONNECTING ROD	BIELLE COMPLET	KOLBENSTANGE	BIELA COMPLETA		1	
12	R12213091A	VITE SPECIALE	SPECIAL SCREW	VIS SPÉCIALE	SPEZIALSCHRAUBE	TORNILLO ESPECIAL		2	
13	R180109001000	SEMICUSCINETTO DI BIELLA (BLU)	HALF-BEARING (BLUE)	DEMI-ROULEMENT (BLUE)	HALBLAGER (BLAU)	SEMI-COJINETE (AZUL)		2	
13	R180109002000	SEMICUSCINETTO DI BIELLA (GIALLO)	HALF-BEARING (YELLOW)	DEMI-ROULEMENT (JAUNE)	HALBLAGER (GELB)	SEMI-COJINETE (AMARILLO)		2	
13	R180109000000	SEMICUSCINETTO DI BIELLA (ROSSO)	HALF-BEARING (RED)	DEMI-ROULEMENT (ROUGE)	HALBLAGER (ROT)	SEMI-COJINETE (ROJO)		2	
14	R13113051A	GUARNIZIONE CILINDRO CARTER	CYLINDER-CRANKCASE GASKET	GARNITURE CYLINDRE CARTER	ZYLINDER/ GEHÄUSEDICHTUNG	JUNTA CILINDRO CARTER		1	

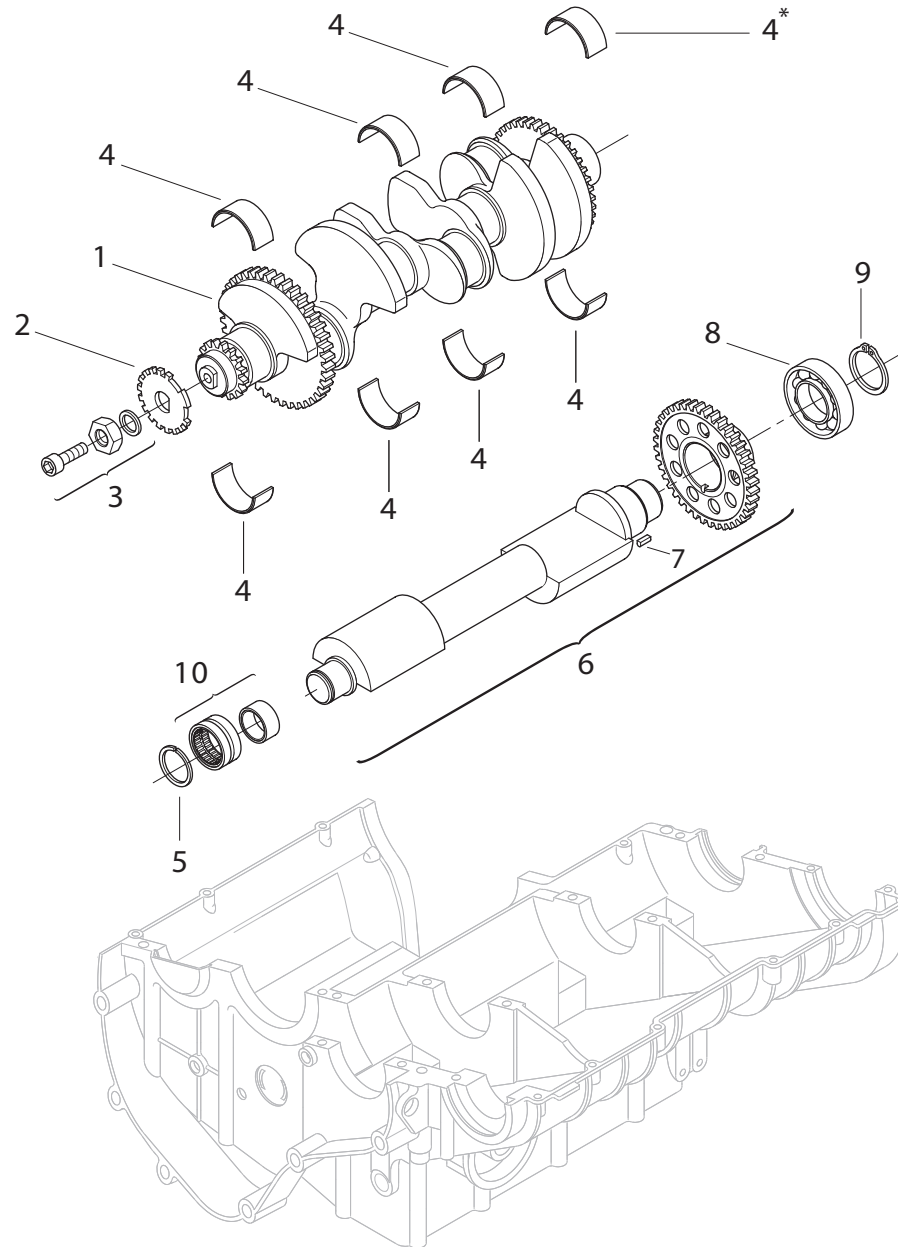

4*

SEMICUSCINETTO DI BANCO		
STD	COLORE COLOUR COULEUR FARBE COLOR	SELEZIONE SELECTION SELECTION AUSWAHL SELECCION
A	Rosso Red Rouge Rot Rojo	1.918 - 1.922
B	Blu Blue Bleu Blau Azul	1.922 - 1.926
C	Giallo Yellow Jaune Gelb Amarillo	1.926 - 1.930
Ø sede std A rosso Ø seat std A red Ø siège std A rouge Ø sitz std A rot Ø sede std A rojo		41.830 - 41.836
Ø sede std A blu Ø seat std A blue Ø siège std A bleu Ø sitz std A blau Ø sede std A azul		41.837 - 41.843
Ø sede std A giallo Ø seat std A yellow Ø siège std A jaune Ø sitz std A gelb Ø sede std A amarillo		41.843 - 41.850
Ø albero std unico Ø single std shaft Ø arbre std unique Ø welle std einheitl Ø arbol std único		37.960 - 37.970

POS. NO. INDEX POS.	N. CODICE CODE NO. Nr. CODE ATRIKEL Nr. CODICO Nr.	DESCRIZIONE	DESCRIPTION	DESIGNATION	BEZEICHNUNG	DENOMINACION	NOTE NOTES NOTES MARKS NOTAS	Q.TA' Q.TY Q.TE M.GE C.AD	
1	R12123231A	ALBERO MOTORE	CRANKSHAFT	ARBRE MOTEUR	ANTRIEBSWELLE	CIGUEÑAL		1	
2	R300033006000	RUOTA FONICA	WHEEL SPEED	ROUE PHONIQUE	GESCHWINDIGKEITS	RUEDA FÓNICA		1	
3	R300000179000	KIT FISSAGGIO RUOTA FONICA	KIT WHEEL SPEED	KIT ROUE PHONIQUE	KIT GESCHWINDIGKEITS	KIT RUEDA FÓNICA		1	
4	R180102000000	SEMICUSCINETTO ROSSO	RED HALF-BEARING	DEMI-ROULEMENT ROUGE	HALBLAGER ROT	SEMI-COJINETE ROJO		2	
4	R180102001000	SEMICUSCINETTO BLU	BLUE HALF-BEARING	DEMI-ROULEMENT BLEU	HALBLAGER BLAU	SEMI-COJINETE AZUL		2	
4	R180102002000	SEMICUSCINETTO GIALLO	YELLOW HALF-BEARING	DEMI-ROULEMENT JAUNE	HALBLAGER GELB	SEMI-COJINETE AMARILLO		2	
5	R92450250D	ANELLO ELASTICO	SNAP RING	BAGUE ÉLASTIQUE	SPRENGRING	SEAGER		1	
6	R12423241A	ALBERO DI BILANCIAMENTO	BALANCE SHAFT	AXE D'ÉQUILIBRE	BALANCE WELLE	EJE DEL BALANCE		1	
7	R92750389C	RULLO	ROLLER CAGE	ROULEAU	RULO	RODILLO		1	
8	R12443081A	CUSCINETTO A SFERE	BALL BEARING	ROULEMANT À BILLES	KUGELLAGER	RODAMIENTO DE BOLAS		1	
9	R92452200D	ANELLO ELASTICO	SNAP RING	BAGUE ÉLASTIQUE	SPRENGRING	SEAGER		1	
10	R12443221A	CUSCINETTO A RULLI	ROLLER BEARING	COUSSINET A ROULEAUX	ROLLENLAGER	COJINETE RODILLOS		1	

COPPIA SEMICARTER



COPPIA SEMICARTER



HALF CRANKCASES



DEMI-CARTERS



GEHÄUSEHÄLFTE



PAREJA SEMI-CARTER

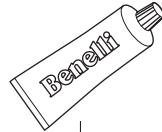

12

11

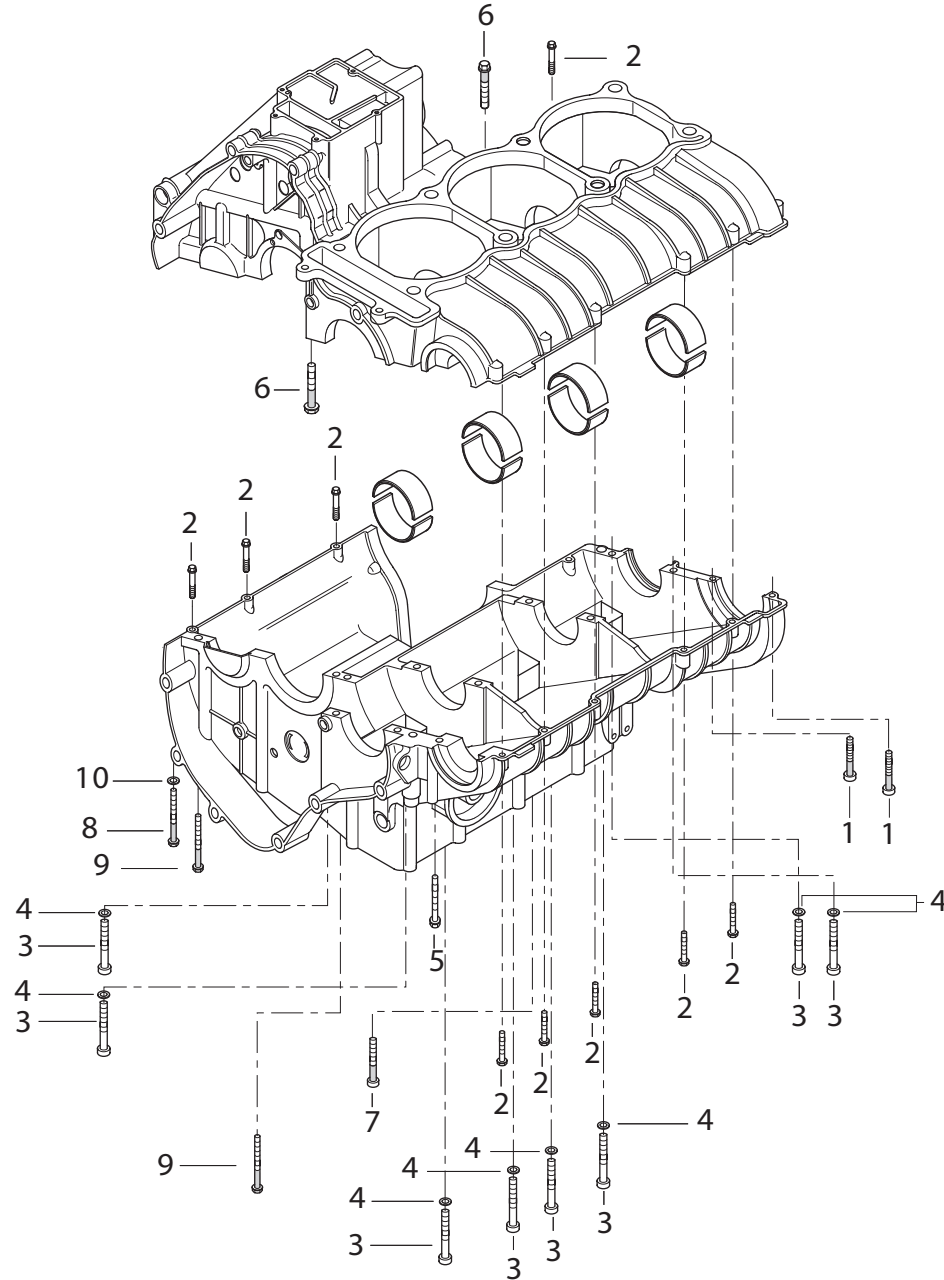



COPPIA SEMICARTER



HALF CRANKCASES



DEMI-CARTERS



GEHÄUSEHÄLFTE



PAREJA SEMI-CARTER

POS. NO. N. INDEX POS.	N. CODICE CODE NO. Nr. CODE ATRIKEL Nr. CODICO Nr.	DESCRIZIONE	DESCRIPTION	DESIGNATION	BEZEICHNUNG	DENOMINACION	NOTE NOTES MARKE NOTAS	Q.TA' Q.TY Q.TE M.GE C.AD	
1	R90751492B	VITE	SCREW	VIS	SCHRAUBE	TORNILLO		2	
2	R90750722B	VITE	SCREW	VIS	SCHRAUBE	TORNILLO		9	
3	R90254470C	VITE	SCREW	VIS	SCHRAUBE	TORNILLO		8	
4	R180204017000	RONDELLA	WASHER	RONDELLE	UNTERLESCHIEBE	ARANDELA		8	
5	R90750772B	VITE	SCREW	VIS	SCHRAUBE	TORNILLO		1	
6	R90751292B	VITE	SCREW	VIS	SCHRAUBE	TORNILLO		2	
7	R90251370C	VITE	SCREW	VIS	SCHRAUBE	TORNILLO		1	
8	R90251410C	VITE	SCREW	VIS	SCHRAUBE	TORNILLO		1	
9	R90251430C	VITE	SCREW	VIS	SCHRAUBE	TORNILLO		2	
10	R92050187A	RONDELLA	WASHER	RONDELLE	UNTERLESCHIEBE	ARANDELA		1	
11	R3009001650B3	COPPIA SEMICARTER	HALF CRANKCASES	DEMI-CARTERS	GEHÄUSEHÄLFTE	PAREJA SEMI-CARTER		1	
12	R310091014000	GUARNIZIONE LIQUIDA	FLUID SEALANT	COLLE LIQUIDE POUR JOINT	FLÜSSIGE DICHTUNG	SELLADOR JUNTA LÍQUIDA		1	

ASSIEME CARTER

ASSIEME CARTER

GUARD ASSEMBLY

ESEMBLE CARTERS

GEHÄUSE KOMPLETT

GRUPO CARTER

TAVOLA
DRAWING
TABLE
BILD
TABLA

006

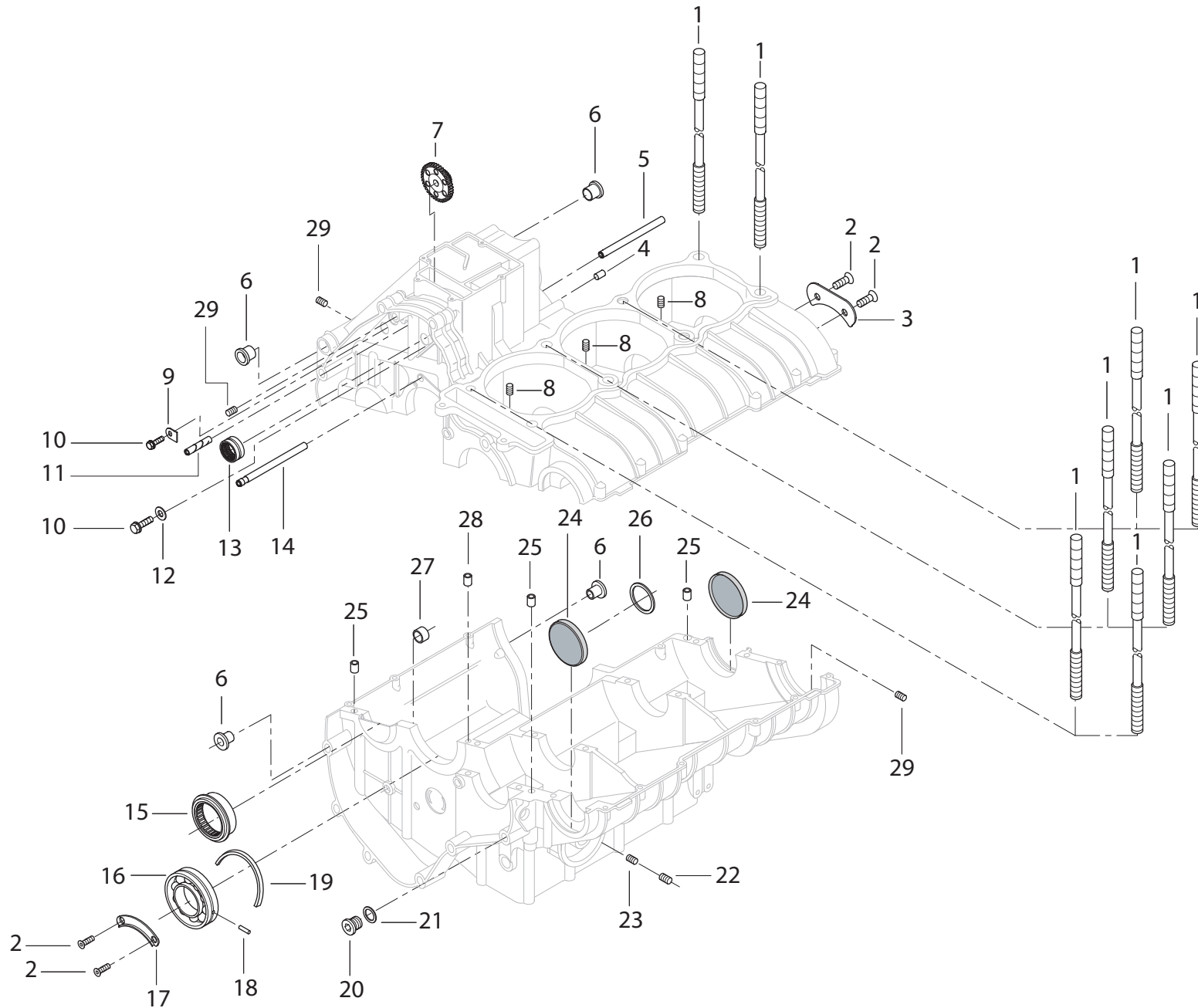

POS. NO. N. INDEX POS.	N. CODICE CODE NO. Nr. CODE ATRIKEL Nr. CODICO Nr.	DESCRIZIONE	DESCRIPTION	DESIGNATION	BEZEICHNUNG	DENOMINACION	NOTE NOTES MARKE NOTAS	Q.TA' Q.TY Q.TE M.GE C.AD	
1	R14413061A	PRIGIONIERO TESTA	HEAD STUD BOLT	GOUJON CULASSE	STIFTSCHRAUBE ZILINDERKOPF	TORNILLO SIN FIN CULATA		8	
2	R90650502B	VITE	SCREW	VIS	SCHRAUBE	TORNILLO		4	
3	R11013251A	PIASTRINA	PLATE	PLAQUETTE	PLÄTTCHEN	PLACA		1	
4	R16313041A	BUSSOLA	BUSH	DOUILLE	BUCHSE	CASQUILLO		1	
5	R180207009000	TUBO OLIO	OIL PIPE	CONDUITE D' HUILE	ÖLLEITUNG	TUBO ACEITE		1	
6	R21213861A	BOCCOLA	BUSH	DOUILLE	BUCHSE	CASQUILLO		4	
7	R19113201A	INGRANAGGIO Z17/67	GEAR Z17/67	ENGRENAGE Z17/67	ZAHNRAD Z17/67	ENGRANAJE Z17/67		1	
8	R180107000000	GETTO OLIO	OIL JET	JET D' HUILE	ÖLSTRAHL	CHORRO ACEITE		3	
9	R11013091A	PIASTRINO	PLATE	PLAQUETTE	PLÄTTCHEN	LÁMINA		1	
10	R90750652B	VITE	SCREW	VIS	SCHRAUBE	TORNILLO		2	
11	R19113041A	ALBERINO INGRANAGGI	GEARS SHAFT	ARBRE ENGRENAGE	ZAHNRADSPINDEL	ÁRBOL ENGRANAJES		1	
12	R16313211A	RONDELLA	WASHER	RONDELLE	UNTERLEGSCHIEBE	ARANDELA		1	
13	R11043141A	CUSCINETTO A RULLI	ROLLER BEARING	COUSSINET A ROULEAUX	ROLLENLAGER	COJINETE RODILLOS		1	
14	R11023781A	TUBO	TUBE	TUBE	ROHR	TUBO		1	
15	R11043921A	CUSCINETTO A RULLI	ROLLER BEARING	COUSSINET A ROULEAUX	ROLLENLAGER	COJINETE RODILLOS		1	
16	R16344151A	CUSCINETTO	BEARING	ROULEMENT	LAGER	COJINETE		1	
17	R11013711A	PIASTRINA	PLATE	PLAQUETTE	PLÄTTCHEN	PLACA		1	
18	R11043431A	SPINA	PIN	GOUPILLE	STIFT	PASADOR		1	
19	R180357182000	ANELLO CUSCINETTO	BEARING RING	BAGUE ROULEMENT	RING LAGER	ANILLO COJINETE		1	
20	R11043501A	TAPPO	CAP	BOUCHON	VERSCHLUß	TAPÓN		1	
21	R11043491A	RONDELLA DI TENUTA	STOP WASHER	RONDELLE D' ETANCHÉITÉ	DICHTUNGSRING	ARANDELA DE RETÉN		1	
22	R11043481A	TAPPO FILETTATO	THREADED CAP	BOUCHON FILETÉE	GEWINDEVERSCHLUß	TAPÓN FILETEADO		1	
23	R11013811A	GRANO	DOWEL	VIS SANS TÊTE	STIFT	CLAVIJA		1	
24	R11043071A	COPERCHIO	COVER	COUVERCLE	DECKEL	TAPA		2	

ASSIEME CARTER

 ASSIEME CARTER

 GUARD ASSEMBLY

 ESEMBLE CARTERS

 GEHÄUSE KOMPLETT

 GRUPO CARTER

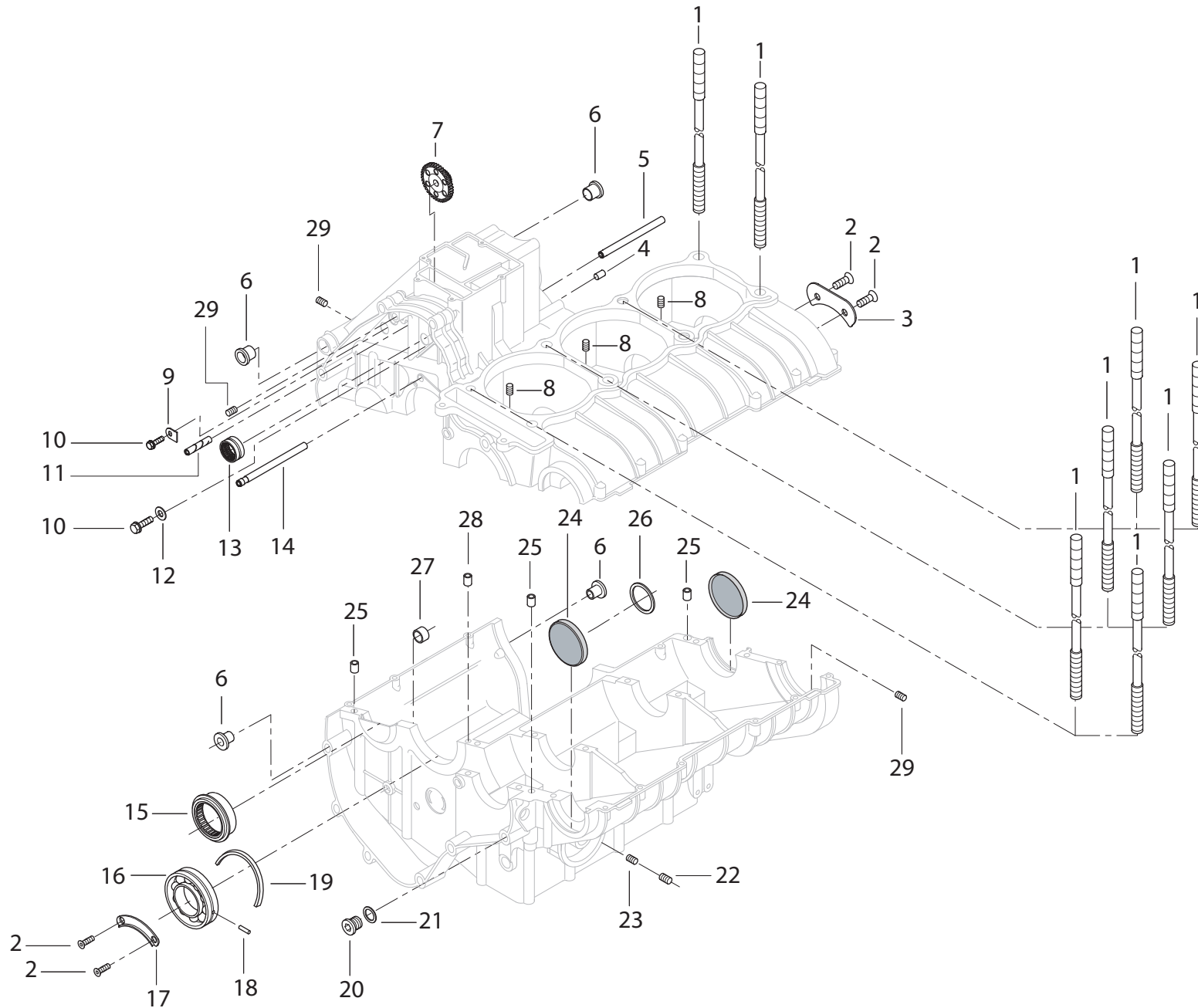

POS. NO. N. INDEX POS.	N. CODICE CODE NO. Nr. CODE ATRIKEL Nr. CODICO Nr.	DESCRIZIONE	DESCRIPTION	DESIGNATION	BEZEICHNUNG	DENOMINACION	NOTE NOTES MARKE NOTAS	Q.TA' Q.TY Q.TE M.GE C.AD	
25	R11013081A	BUSSOLA DI CENTRAGGIO	CENTRING BUSH	DOUILLE DE CENTRAGE	ZENTRIERBUCHSE	CASQUILLO DE CENTRADO		3	
26	R11013761A	ANELLO	RING	BAGUE	RING	ANILLO		1	
27	R11043161A	BOCCOLA	BUSH	DOUILLE	BUCHSE	CASQUILLO		1	
28	R16313361A	BUSSOLA DI CENTRAGGIO	CENTRING BUSH	DOUILLE DE CENTRAGE	ZENTRIERBUCHSE	CASQUILLO DE CENTRADO		1	
29	R14043141A	GRANO	DOWEL	VIS SANS TÊTE	STIFT	CLAVIJA		3	

COPERCHI MOTORE

🇮🇹 COPERCHI MOTORE

🇬🇧 ENGINE COVERS

🇫🇷 COUVERCLES MOTEUR

🇩🇪 MOTOR DECKEL

🇪🇸 TAPAS MOTOR

TAVOLA
DRAWING
TABLE
BILD
TABLA

007

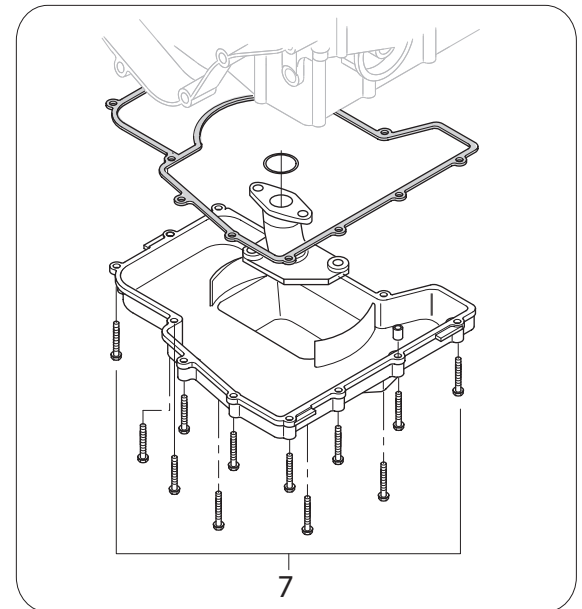
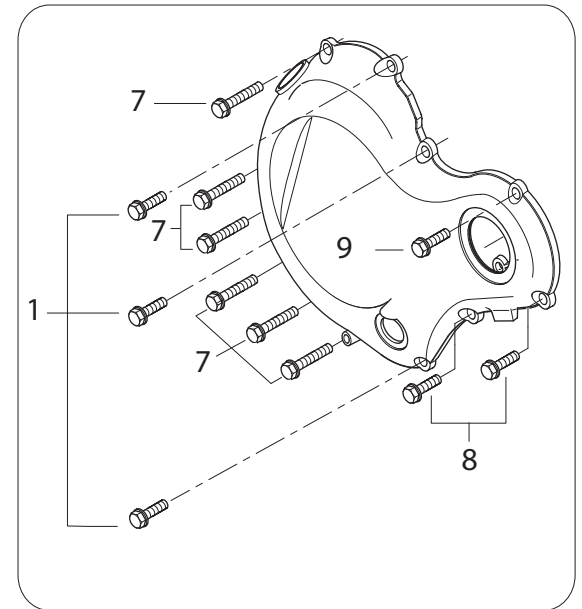
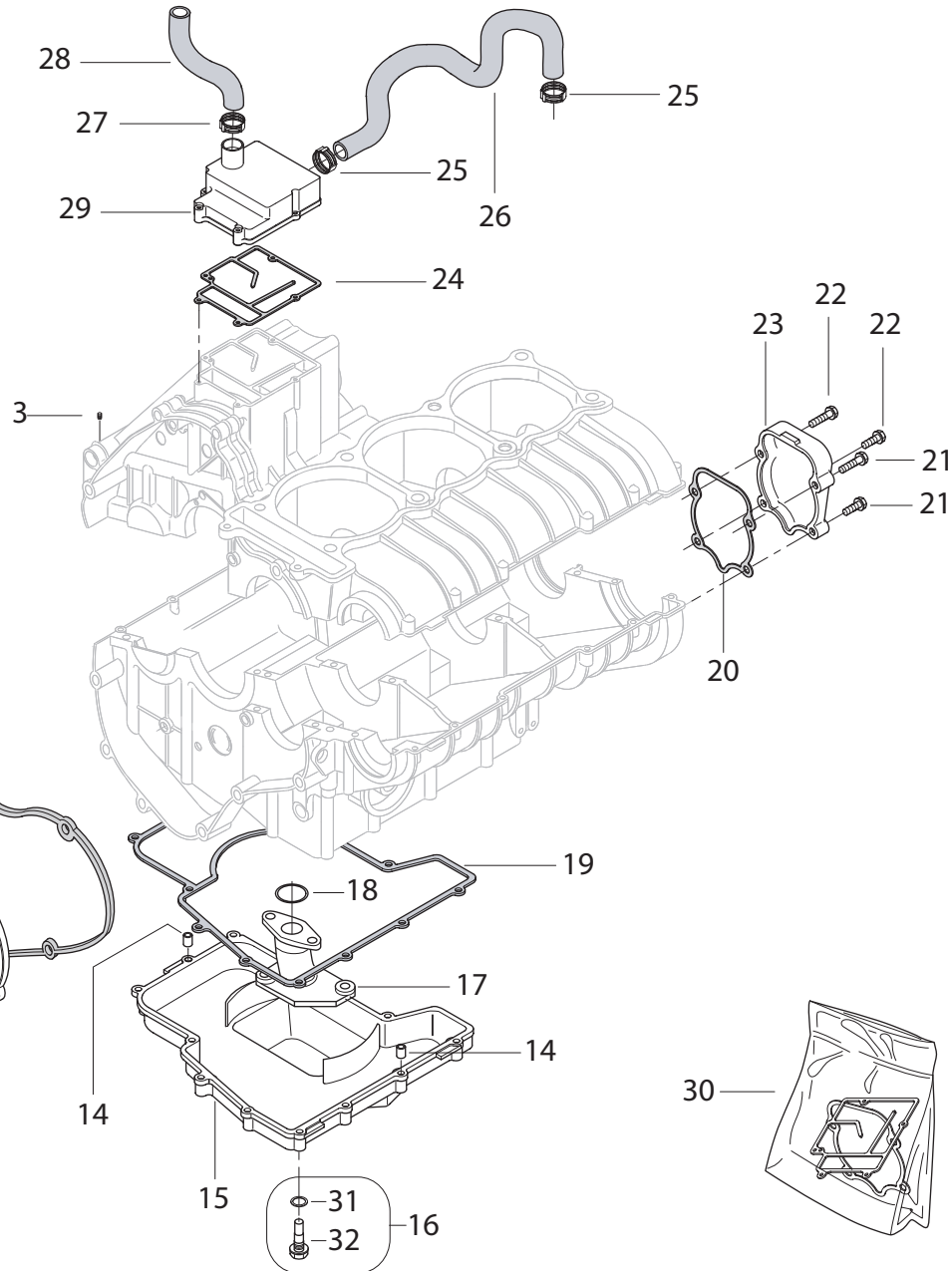
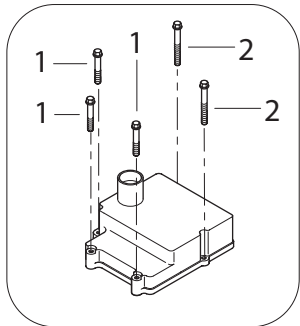

POS. NO. N. INDEX POS.	N. CODICE CODE NO. Nr. CODE ATRIKEL Nr. CODICO Nr.	DESCRIZIONE	DESCRIPTION	DESIGNATION	BEZEICHNUNG	DENOMINACION	NOTE NOTES MARKE NOTAS	Q.TA' Q.TY Q.TE M.GE C.AD	
1	R90750692B	VITE	SCREW	VIS	SCHRAUBE	TORNILLO		6	
2	R90750722B	VITE	SCREW	VIS	SCHRAUBE	TORNILLO		2	
3	R14043141A	TAPPO FILETTATO	THREADED CAP	BOUCHON FILETÉE	GEWINDE VERSCHLUß	TAPÓN FILETEADO		1	
4	R11013681A	GUARNIZIONE COPERCHIO FRIZIONE	CLUTCH COVER GASKET	GARNITURE COUVERCLE EMBRAYAGE	DECKEL DICHTUNG KUPPLUNG	JUNTA TAPA EMBRAGUE		1	
5	R92850109M	GUARNIZIONE OR	O-RING	JOINT D'ÉTANCHÉITÉ	DICHTUNG OR	JUNTA OR		1	
6	R11013401A	TAPPO CARICO OLIO	OIL LOAD PLUG	BOUCHON REMPLISSAGE HUILE	ÖLEINFÜLLSCHRAUBE	TAPÓN CARGO ACEITE		1	
7	R90750712B	VITE	SCREW	VIS	SCHRAUBE	TORNILLO		18	
8	R90750672B	VITE	SCREW	VIS	SCHRAUBE	TORNILLO		2	
9	R90750652B	VITE	SCREW	VIS	SCHRAUBE	TORNILLO		1	
10	R11013911A	TAPPO FASE	PHASE PLUG	BOUCHON PHASE	PHASENSCHRAUBE	TAPÓN FASE		1	
11	R92850259M	GUARNIZIONE OR	O-RING	JOINT D'ÉTANCHÉITÉ	DICHTUNG OR	JUNTA OR		1	
12	R11043391A	OBLO' ISPEZIONE LIVELLO OLIO	OIL LEVEL SIGHT GLASS	HUBLOT D'INPECTION NIVEAU HUILE	ÖLKONTROLLSCHAUGLAS	VISOR EN INSPECCIÓN NIVEL		1	
13	R180201005000	COPERCHIO FRIZIONE	CLUTCH COVER	COUVERCLE EMBRAYAGE	KUPPLUNGSDECKEL	TAPA EMBRAGUE		1	
14	R16313361A	BUSSOLA	BUSH	DOUILLE	BUCHSE	CASQUILLO		2	
15	R180201004000	COPPA OLIO	OIL SUMP	CARTER INFERIEUR (HUILE)	ÖLWANNE	COPA ACEITE		1	
16	R180270005000	TAPPO MAGNETICO	MAGNETIC CAP	BOUCHON MAGNÉTIQUE	MAGNETDECKEL	TAPÓN MAGNÉTICO		1	
17	R180201033001	FILTRO ASPIRAZIONE	INTAKE FILTER	FILTRE ASPIRATION	ANSAUGFILTER	FILTRO ASPRACIÓN		1	
18	R92850139M	GUARNIZIONE OR	O-RING	JOINT D'ÉTANCHÉITÉ	DICHTUNG OR	JUNTA OR		1	
19	R11013791A	GUARNIZIONE COPPA OLIO	OIL SUMP GASKET	GARNITURE CARTER INFERIEUR (HUILE)	DICHTUNG ÖLWANNE	JUNTA COPA ACEITE		1	
20	R11013221A	GUARNIZIONE COPERCHIO	COVER GASKET	GARNITURE COUVERCLE	DECKELDICHTUNG	JUNTA TAPA		1	
21	R90750512B	VITE	SCREW	VIS	SCHRAUBE	TORNILLO		2	
22	R90750532B	VITE	SCREW	VIS	SCHRAUBE	TORNILLO		2	
23	R1802010100CE	COPERCHIO	COVER	COUVERCLE	DECKEL	TAPA		1	
24	R11013241A	GUARNIZIONE COPERCHIO BLOW-BY	BLOW-BY COVER GASKET	GARNITURE COUVERCLE BLOW-BY	DECKELDICHTUNG BLOW-BY	JUNTA TAPA BLOW-BY		1	

COPERCHI MOTORE

🇮🇹 COPERCHI MOTORE

🇬🇧 ENGINE COVERS

🇫🇷 COUVERCLES MOTEUR

🇩🇪 MOTOR DECKEL

🇪🇸 TAPAS MOTOR

TAVOLA
DRAWING
TABLE
BILD
TABLA

007

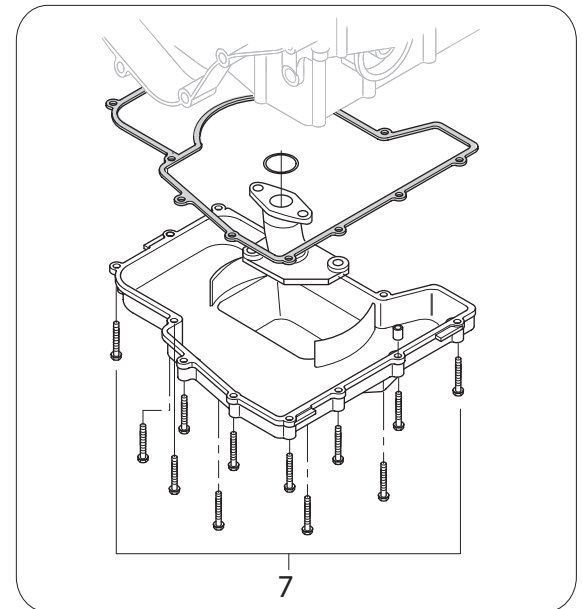
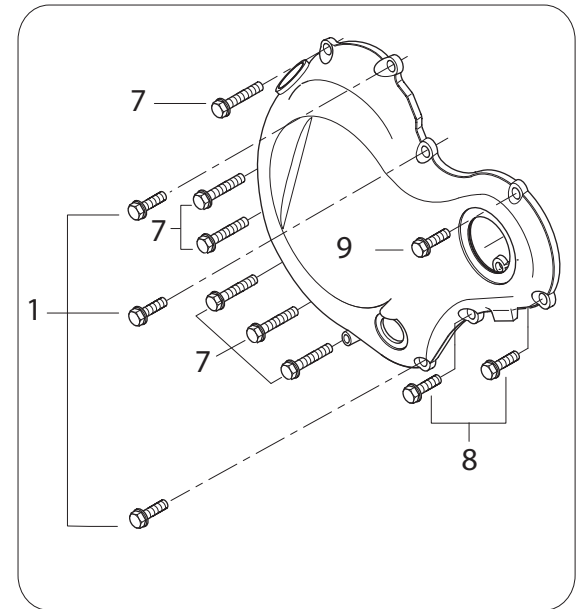
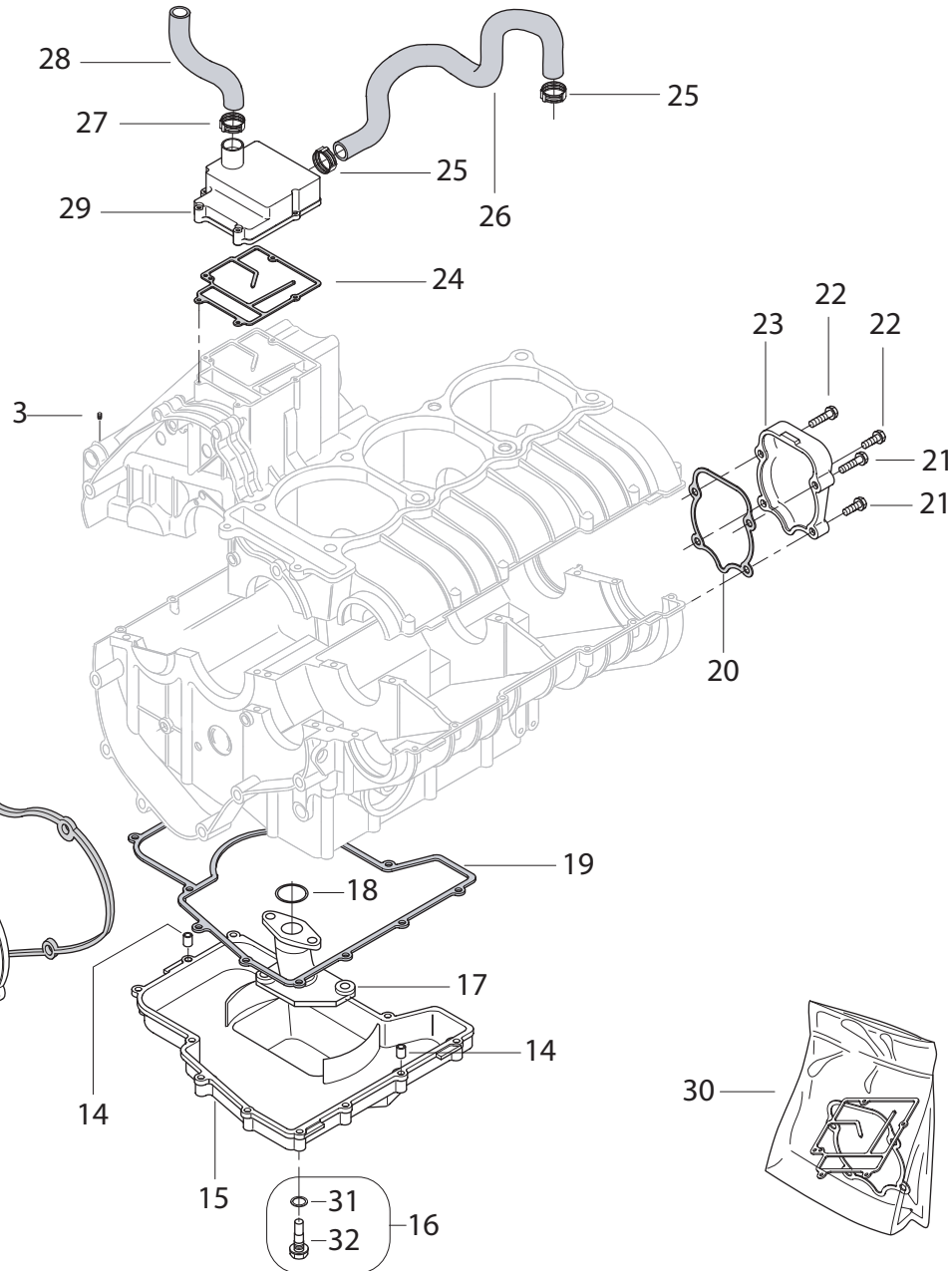
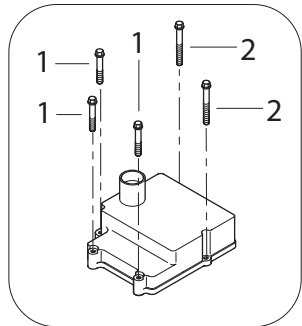



COPERCHI MOTORE



ENGINE COVERS



COUVERCLES MOTEUR



MOTOR DECKEL



TAPAS MOTOR

POS. NO. N. INDEX POS.	N. CODICE CODE NO. Nr. CODE ATRIKEL Nr. CODICO Nr.	DESCRIZIONE	DESCRIPTION	DESIGNATION	BEZEICHNUNG	DENOMINACION	NOTE NOTES MARKE NOTAS	Q.TA' Q.TY Q.TE M.GE C.AD	
25	R180184002000	FASCETTA	CLAMP	COLLIER	SHELLE	ABRAZADERA		2	
26	R180107003000	TUBO SFIATO TESTA	HEAD VENT PIPE	TUBE EVENT TETE	EVENTLUFTÜNGSSCHLAUCH KOPF	TUBO RESPIRADERO CABEZA		1	
27	R180184000000	FASCETTA	CLAMP	COLLIER	SHELLE	ABRAZADERA		1	
28	R180190118000	TUBO SFIATO OLIO	OIL BREATHER TUBE	TUBE D' EVENT HUILE	ÖLENTLÜFERROHR	TUBO RESPIRADERO ACEITE		1	
29	R180201003000	COPERCHIO BLOW-BY	BLOW-BY COVER	COUVERCLE BLOW-BY	DECKEL BLOW-BY	TAPA BLOW-BY		1	
30	R180200152000	KIT GUARNIZIONI CARTER	GASKET KIT	JEU GARNITURE	KIT DICHTUNG	KIT JUNTA		1	
31	R180270007000	RONDELLA	WASHER	RONDELLE	UNTERLEGSCHIEBE	ARANDELA		1	
32	R180270006000	TAPPO MAGNETICO	MAGNETIC CAP	BOUCHON MAGNÉTIQUE	MAGNETDECKEL	TAPÓN MAGNÉTICO		1	

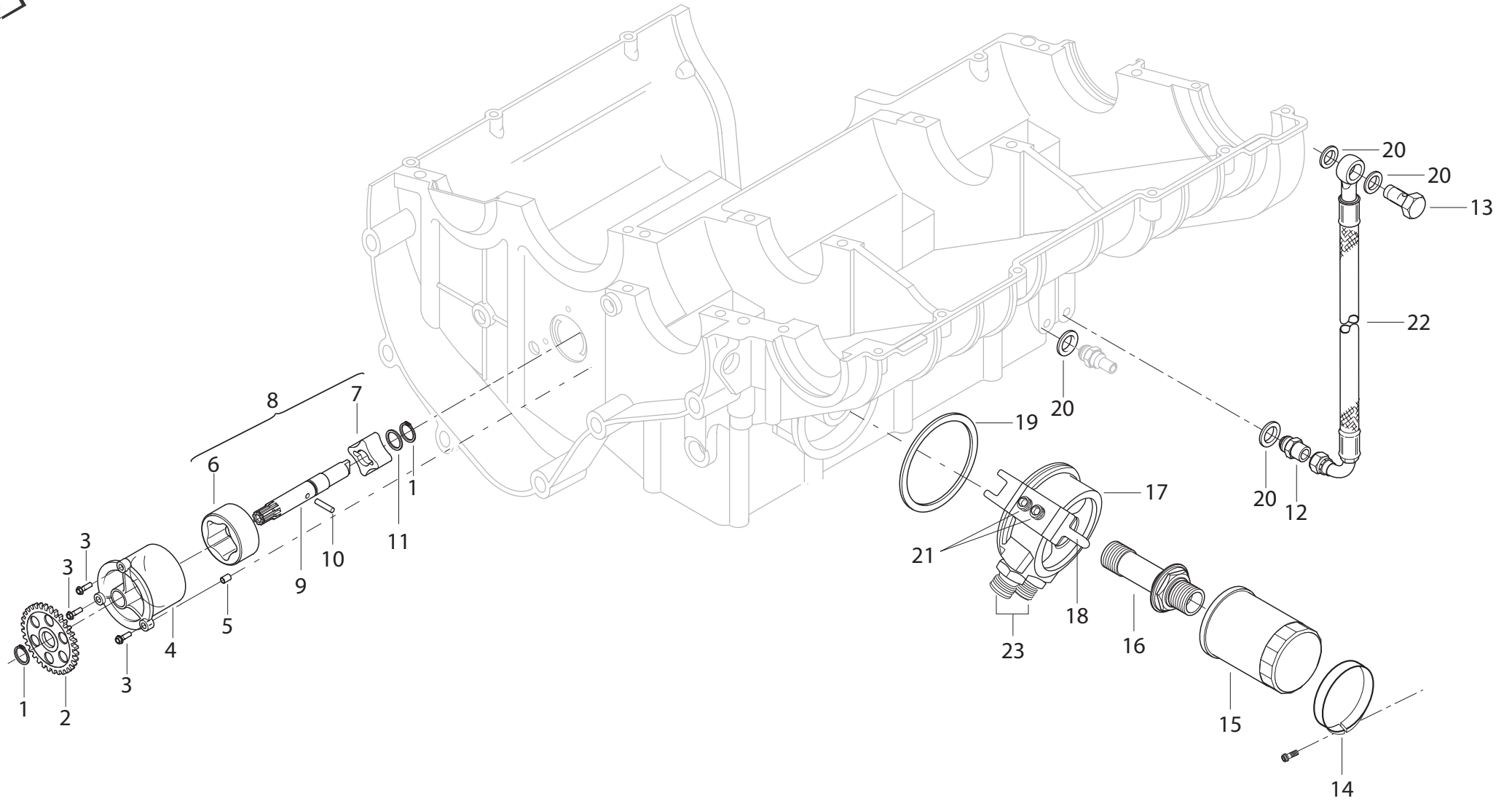

POS. NO. N. INDEX POS.	N. CODICE CODE NO. Nr. CODE ATRIKEL Nr. CODICO Nr.	DESCRIZIONE	DESCRIPTION	DESIGNATION	BEZEICHNUNG	DENOMINACION	NOTE NOTES NOTES MARKE NOTAS	Q.TA' Q.TY Q.TE M.GE C.AD	
1	R92450140D	ANELLO	RING	BAGUE	RING	ANILLO		2	
2	R11613081A	INGRANAGGIO DI COMANDO Z 34	DRIVE GEAR Z 34	ENGRENAGE COMMANDE Z 34	DREHSTOMGENERATOR Z 34	ENGRANAJE MANDO Z 34		1	
3	R90750672B	VITE	SCREW	VIS	SCHRAUBE	TORNILLO		3	
4	R180206001000	POMPA OLIO	OIL PUMP	POMPE À HUILE	ÖLPUMPE	BOMBA ACEITE		1	
5	R11613101A	BUSSOLA	BUSH	DOUILLE	BUCHSE	CASQUILLO		1	
6	R11613031A	ROTORE ESTERNO	OUTER ROTORS	EXTERNE ROTORS	ROTOREN DECKEL	ROTOR EXTERIOR		1	
7	R11613021A	ROTORE INTERNO	INNER ROTORS	INTERNE ROTORS	ROTOREN INNERES	ROTOR INTERIOR		1	
8	R180106003000	ROTORI POMPA OLIO	OIL PUMP ROTORS	POMPE À HUILE ROTORS	ROTOREN ÖLPUMPE	ROTOR BOMBA ACEITE		1	
9	R11613111A	ALBERO POMPA OLIO	OIL PUMP SHAFT	ARBRE POMPE À HUILE	WELLE ÖLPUMPE	ÁRBOL BOMBA ACEITE		1	
10	R92750839C	RULLO	ROLLER	ROULEAU	ROLLE	RODILLO		1	
11	R16044401A	ANELLO DI TENUTA	SEAL RING	BAGUE D'ÉTANCHÉITÉ	DICHTRING	ANILLO DE RETÉN		1	
12	R11543451A	RACCORDO	UNION	RACCORD	ANSCHLUß	EMPALME		1	
13	R11543591A	VITE	SCREW	VIS	SCHRAUBE	TORNILLO		1	
14	R18343751A	FASCETTA	CLAMP	COLLIER	SHELLE	ABRAZADERA		1	
15	R180107101000	FILTRO OLIO	OIL FILTER	FILTRE À HUILE	ÖLFILTER	FILTRO ACEITE		1	
16	R180407014000	VITE SPECIALE	SPECIAL SCREW	VIS SPÉCIALE	SPEZIALSCHRAUBE	TORNILLO ESPECIAL		1	
17	R300007011000	DISTRIBUTORE	SHIM	ROSETTE DE BUTÉE ÉPAISSEUR	DISTANZSCHEIBE STÄRKE	ARANDELA DE ESPESORACIÓN		1	
18	R180457150000	PIASTRINO	WATER OIL EXCHANGER COMPLETE	ÉCHANGEUR COMPLET D'HUILE DE L'EAU	AUSTAUSCHER WASSER-ÖL KOMPLETT	CAMBIADOR COMPLETO DEL ACEITE DEL AGUA		1	
19	R180407017000	ANELLO DI TENUTA	SEAL RING	BAGUE D'ÉTANCHÉITÉ	DICHTRING	ANILLO DE RETÉN		1	
20	R180132106000	RONDELLA	WASHER	RONDELLE	UNTERLEGSCHIEBE	ARANDELA		4	
21	R90750372B	VITE	SCREW	VIS	SCHRAUBE	TORNILLO		2	
22	R11513431A	TUBO	TUBE	TUBE	ROHR	TUBO		1	
23	R180407015000	ADATTATORE	ADAPTOR	ADAPTATEUR	PASSTÜCK	ADAPTADOR		2	

POMPA ACQUA

 POMPA ACQUA

 WATER PUMP

 POMPE EAU

 WASSERPUMPE

 BOMBA AGUA

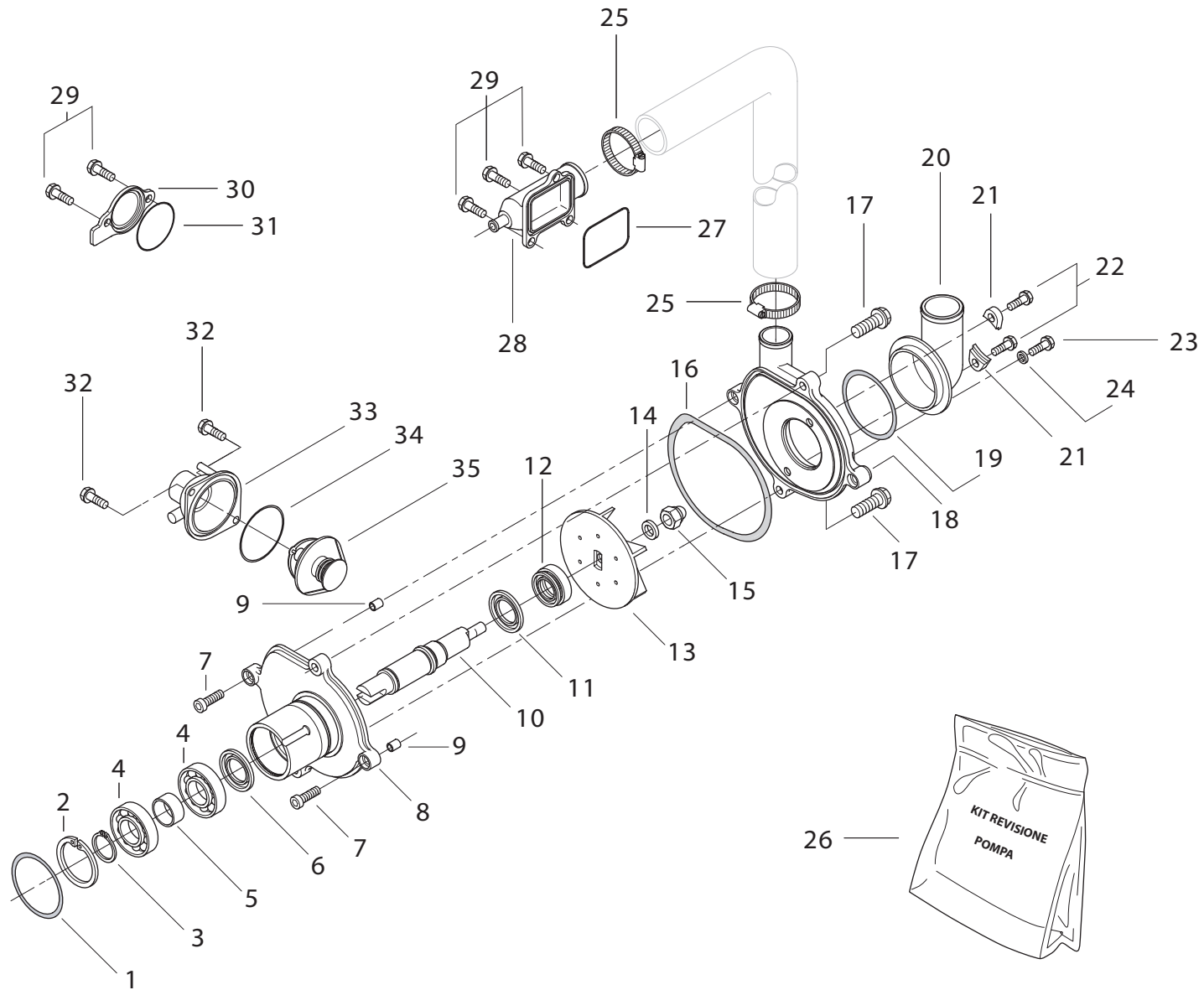

POS. NO. N. INDEX POS.	N. CODICE CODE NO. Nr. CODE ATRIKEL Nr. CODICO Nr.	DESCRIZIONE	DESCRIPTION	DESIGNATION	BEZEICHNUNG	DENOMINACION	NOTE NOTES NOTES MARKE NOTAS	Q.TA' Q.TY Q.TE M.GE C.AD	
1	R92850049M	ANELLO DI TENUTA	SEAL RING	BAGUE D'ÉTANCHÉITÉ	DICHTRING	ANILLO DE RETÉN		1	
2	R92550320D	SEEGER INTERNO	INNER SEEGER	CIRCLIP INTERNE	SEEGER INNEN	SEEGER INTERIOR		1	
3	R92450150D	SEEGER ESTERNO	OUTER SEEGER	CIRCLIP EXTERNE	SEEGER AUSSEN	SEEGER EXTERIOR		1	
4	R17143211A	CUSCINETTO	BEARING	ROULEMENT	LAGER	COJINETE		2	
5	R17113111A	DISTANZIALE	SPACER	ENTRETOISE	DISTANZSTÜCK	DISTANCIAL		1	
6	R17143101A	ANELLO DI TENUTA	SEAL RING	BAGUE D'ÉTANCHÉITÉ	DICHTRING	ANILLO DE RETÉN		1	
7	R90350672B	VITE	SCREW	VIS	SCHRAUBE	TORNILLO		2	
8	R180229002000	CORPO POMPA ACQUA	WATER PUMP BODY	CORPS POMPE EAU	KÖRPER WASSERPUMPE	CUERPO BOMBA AGUA		1	
9	R16313361A	BUSSOLA DI CENTRAGGIO	CENTRING BUSH	DOUILLE DE CENTRAGE	ZENTRIERBUCHSE	CASQUILLO DE CENTRADO		2	
10	R17113061A	ALBERO POMPA ACQUA	WATER PUMP SHAFT	ARBRE POMPE EAU	WASSERPUMPEWELLE	ARBOL BOMBA AGUA		1	
11	R17143091A	CONTROFACCIA	SEAL	ÉTANCHÉITÉ HYDRAULIQUE	HYDRAULIKDICHTUNG	RETÉN HIDRÁULICO		1	
12	R17143081A	TENUTA MECCANICA	MECHANICAL SEAL	TENUE MÉCANIQUE	MECHANISCHE DICHTUNG	JUNTA MECÁNICA		1	
13	R180229003000	GIRANTE POMPA ACQUA	WATER PUMP FAN	COURONNE POMPE EAU	LÄUFERRAD DER WASSERPUMPE	ROTOR BOMBA AGUA		1	
14	R92050158E	RONDELLA DI TENUTA	STOP WASHER	RONDELLE D'ÉTANCHÉITÉ	DICHTUNGSRING	ARANDELA DE RETÉN		1	
15	R91851029G	DADO CIECO	CAP NUT	ECROU BORGNE	BILNDE MUTTER	TUERCA CIEGA		1	
16	R92850029M	ANELLO DI TENUTA	SEAL RING	BAGUE D'ÉTANCHÉITÉ	DICHTRING	ANILLO DE RETÉN		1	
17	R90750722B	VITE	SCREW	VIS	SCHRAUBE	TORNILLO		2	
18	R180201011000	COPERCHIO POMPA ACQUA	WATER PUMP COVER	COUVERCLE POMPE À EAU	WASSERPUMPENDECKEL	TAPA BOMBA AGUA		1	
19	R92850039M	ANELLO DI TENUTA	SEAL RING	BAGUE D'ÉTANCHÉITÉ	DICHTRING	ANILLO DE RETÉN		1	
20	R180229004000	GOMITO ENTRATA ACQUA	WATER ELBOW INLET	COUDE ENTRÉE EAU	KNIESTÜCK WASSEREINLAUF	CODO ENTRADA AGUA		1	
21	R17113031A	PIASTRINO	PLATE	PLAQUETTE	PLÄTTCHEN	LÁMINA		2	
22	R90750652B	VITE	SCREW	VIS	SCHRAUBE	TORNILLO		2	
23	R90750622B	VITE	SCREW	VIS	SCHRAUBE	TORNILLO		1	
24	R17143231A	RONDELLA DI TENUTA	STOP WASHER	RONDELLE D'ÉTANCHÉITÉ	DICHTUNGSRING	ARANDELA DE RETÉN		1	

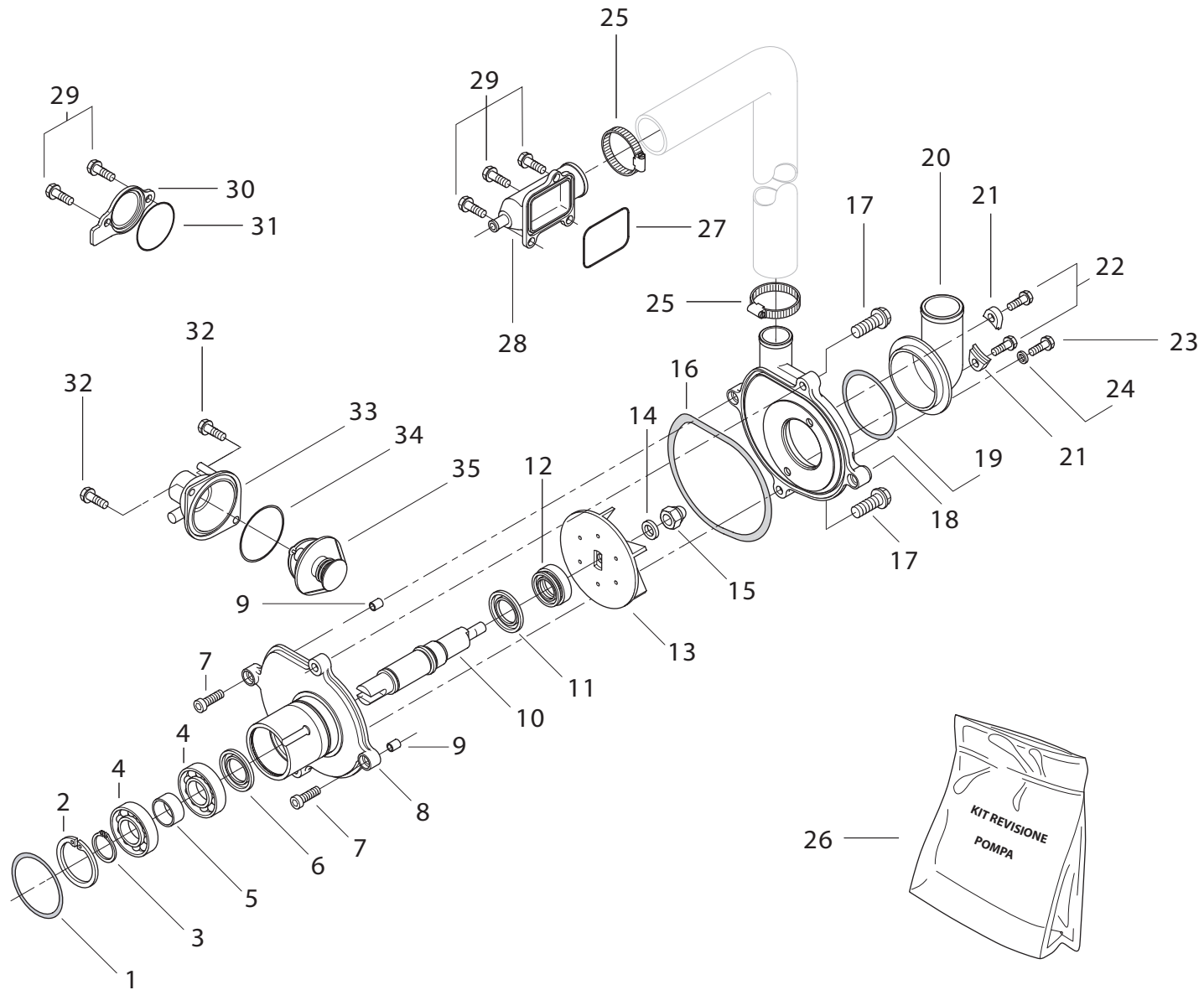

POS. NO. N. INDEX POS.	N. CODICE CODE NO. Nr. CODE ATRIKEL Nr. CODICO Nr.	DESCRIZIONE	DESCRIPTION	DESIGNATION	BEZEICHNUNG	DENOMINACION	NOTE NOTES NOTES MARKE NOTAS	Q.TA' Q.TY Q.TE M.GE C.AD	
25	R95350277B	FASCETTA A VITE	SCREW HOSE CLAMP	COLLIER À VISSER	SCHRAUBENSHELLE	ABRAZADERA A TORNILLO		2	
26	R300000184000	KIT REVISIONE POMPA	KIT REVISION PUMP	KIT RÉVISION POMPE	KIT NEUAUSGABE PUMPE	KIT REVISIÓN BOMBA		1	
27	R92850059M	GUARNIZIONE OR	O-RING	JOINT D'ÉTANCHÉITÉ	DICHTUNG OR	JUNTA OR		1	
28	R180428004000	COLLETTORE ACQUA	WATER MANIFOLD	COLLECTEUR EAU	WASSERKRÜMMER	COLECTOR AGUA		1	
29	R90750672B	VITE	SCREW	VIS	SCHRAUBE	TORNILLO		5	
30	R3000010120CE	COPERCHIO ACQUA	WATER COVER	COUVERCLE EAU	WASSERDECKEL	TAPA AGUA		1	
31	R92850249M	ANELLO DI TENUTA	SEAL RING	BAGUE D'ÉTANCHÉITÉ	DICHTRING	ANILLO DE RETÉN		1	
32	R90750692B	VITE	SCREW	VIS	SCHRAUBE	TORNILLO		2	
33	R180428005000	TAZZA TERMOSTATO	THERMOSTAT BELLEVILLE	BOL THERMOSTAT	THERMOSTATTELLER	TAZA TERMÓSTATO		1	
34	R92850069M	ANELLO DI TENUTA	SEAL RING	BAGUE D'ÉTANCHÉITÉ	DICHTRING	ANILLO DE RÉTEN		1	
35	R17113141A	TERMOSTATO	THERMOSTAT	THERMOSTAT	THERMOSTAT	TERMÓSTATO		1	

FRIZIONE

FRIZIONE

CLUTCH

EMBAYAGE

KUPPLUNG

EMBRAGUE

TAVOLA
DRAWING
TABLE
BILD
TABLA

010

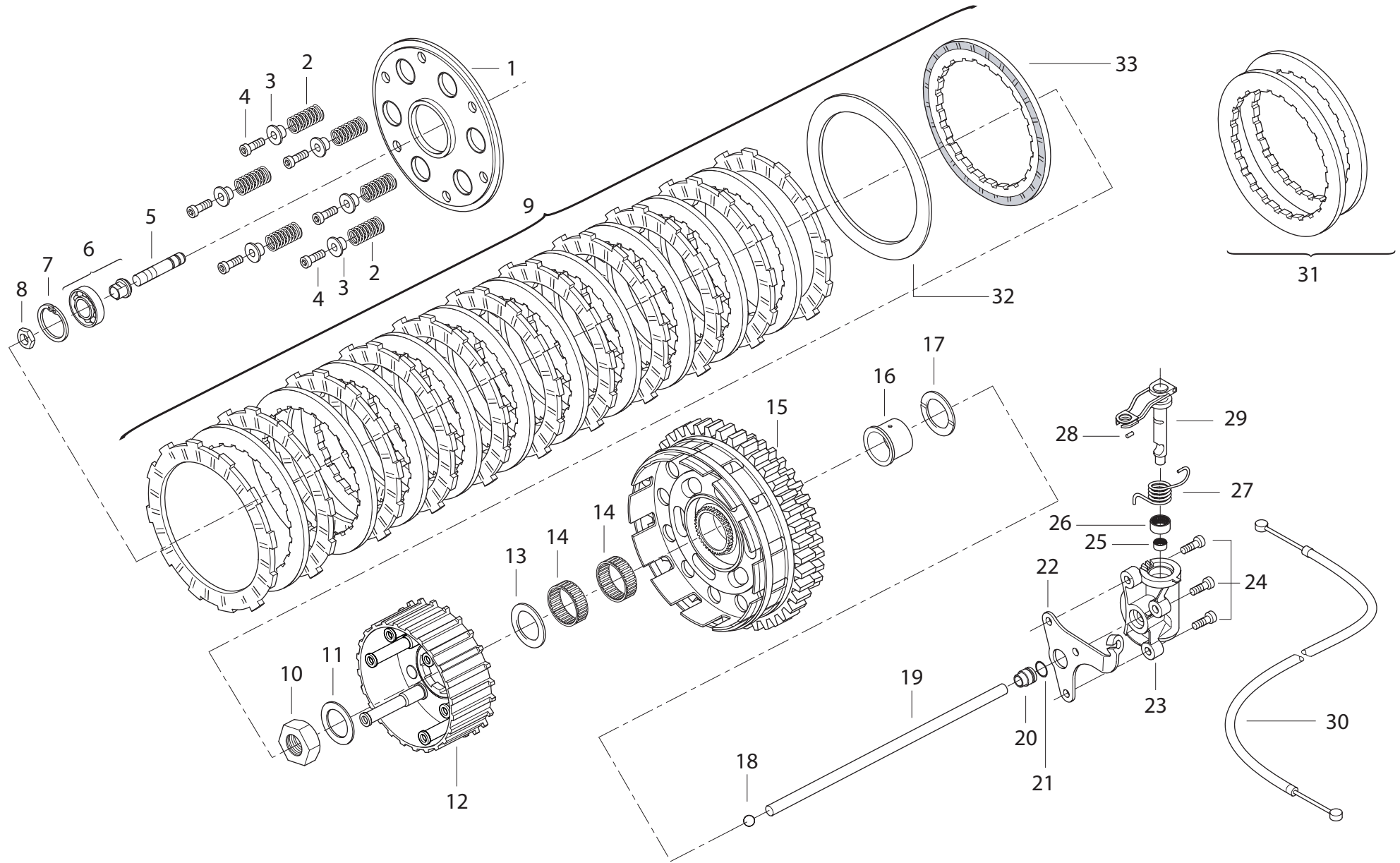

POS. NO. INDEX POS.	N. CODICE CODE NO. Nr. CODE ATRIKEL Nr. CODICO Nr.	DESCRIZIONE	DESCRIPTION	DESIGNATION	BEZEICHNUNG	DENOMINACION	NOTE NOTES MARKE NOTAS	Q.TA' Q.TY Q.TE M.GE C.AD	
1	R180200147001	SPINGIDISCO	PRESSURE PLATE	POUSSE-DISQUE	SCHEIBENDRÜCKER	EMPUJA-DISCO		1	
2	R16043911A	MOLLA FRIZIONE	CLUTCH SPRING	RESSORT EMBRAYAGE	KUPPLUNGSFEDER	MUELLE EMBRAGUE		6	
3	R180124018000	SCODELLINO	RETAINER	CUVETTE	TELLER	PLATILLO		6	
4	R180124025000	VITE	SCREW	VIS	SCHRAUBE	TORNILLO		6	
5	R180224014000	PERNO SPINGIDISCO	PRESSURE PLATE PIN	GOUJON	BOLZEN	PERNO EMPUJA-DISCO		1	
6	R180200146000	CUSCINETTO CON BUSSOLA	BEARING WITH BUSH	ROULEMENT EN DOUILLE	LAGER MIT BUCHSE	COJINETE CON CASQUILLO		1	
7	R92550350D	ANELLO ELASTICO	SNAP RING	BAGUE ÉLASTIQUE	SPRENGRING	SEAGER		1	
8	R16044271A	DADO	NUT	ECROU	MUTTER	TUERCA		1	
9	R300000141000	SERIE DISCHI FRIZIONE	CLUTCH PLATES SET	SÉRIE DE DISQUES EMBRAYAGE	KUPPLUNGSSCHEIBENSATZ	SERIE DISCOS EMBRAGUE		1	
10	R180224015000	DADO ESAGONALE	HEXAGON NUT	ECROU HEXAGONAL	SECHSKANTMUTTER	TUERCA HEXAGONAL		1	
11	R16043811A	MOLLA A TAZZA	SPRING WASHER	BELLEVILLE	TELLERFEDER	ARANDELA DE MUELLE		1	
12	R300024023000	TAMBURO FRIZIONE	CLUTCH DRUM	TAMBOUR EMBRAYAGE	KUPPLUNGSTROMMEL	TAMBOR EMBRAGUE		1	
13	R180224011000	RASAMENTO	SHIM	ROSETTE DE BUTÉE ÉPAISSEUR	DISTANZSCHEIBE STÄRKE	ARANDELA DE ESPESORACIÓN		1	
14	R180220000000	GABBIA A RULLINI	NEEDLE BEARING	BOÎTE À AIGUILLES	NADELKÄFIG	JAULA DE RODILLOS		2	
15	R180200139001	CAMPANA FRIZIONE	CLUTCH HOUSING	CLOCHE EMBRAYAGE	KUPPLUNGSGLOCKE	CAMPANA EMBRAGUE		1	
16	R180224009000	DISTANZIALE	SPACER	ENTRETOISE	DISTANZSTÜCK	DISTANCIAL		1	
17	R180224008000	RASAMENTO	SHIM	ROSETTE DE BUTÉE ÉPAISSEUR	DISTANZSCHEIBE STÄRKE	ARANDELA DE ESPESORACIÓN		1	
18	R92751259C	SFERA	BALL	BILLE	KUGEL	ESFERA		1	
19	R180224016000	ASTA COMANDO FRIZIONE	CLUTCH CONTROL ROD	TIGE DE COMMANDE EMBRAYAGE	KUPPLUNGSSTEUERUNGSSTAB	VARILLA MANDO EMBRAGUE		1	
20	R16014231A	BUSSOLA	BUSH	DOUILLE	BUCHSE	CASQUILLO		1	
21	R92850219M	GUARNIZIONE OR	O-RING	JOINT D'ÉTANCHÉITÉ	DICHTUNG OR	JUNTA OR		1	
22	R180224033000	PIASTRINO	PLATE	PLAQUETTE	PLÄTTCHEN	LÁMINA		1	
23	R180224104000	COMANDO FRIZIONE	CLUTCH CONTROL	COMMANDE EMBRAYAGE	KUPPLUNGSSTEUERUNG	ACCINAMENTO EMBRAGUE		1	
24	R90250672B	VITE	SCREW	VIS	SCHRAUBE	TORNILLO		3	

FRIZIONE

FRIZIONE

CLUTCH

EMBRAYAGE

KUPPLUNG

EMBRAGUE

TAVOLA
DRAWING
TABLE
BILD
TABLA

010

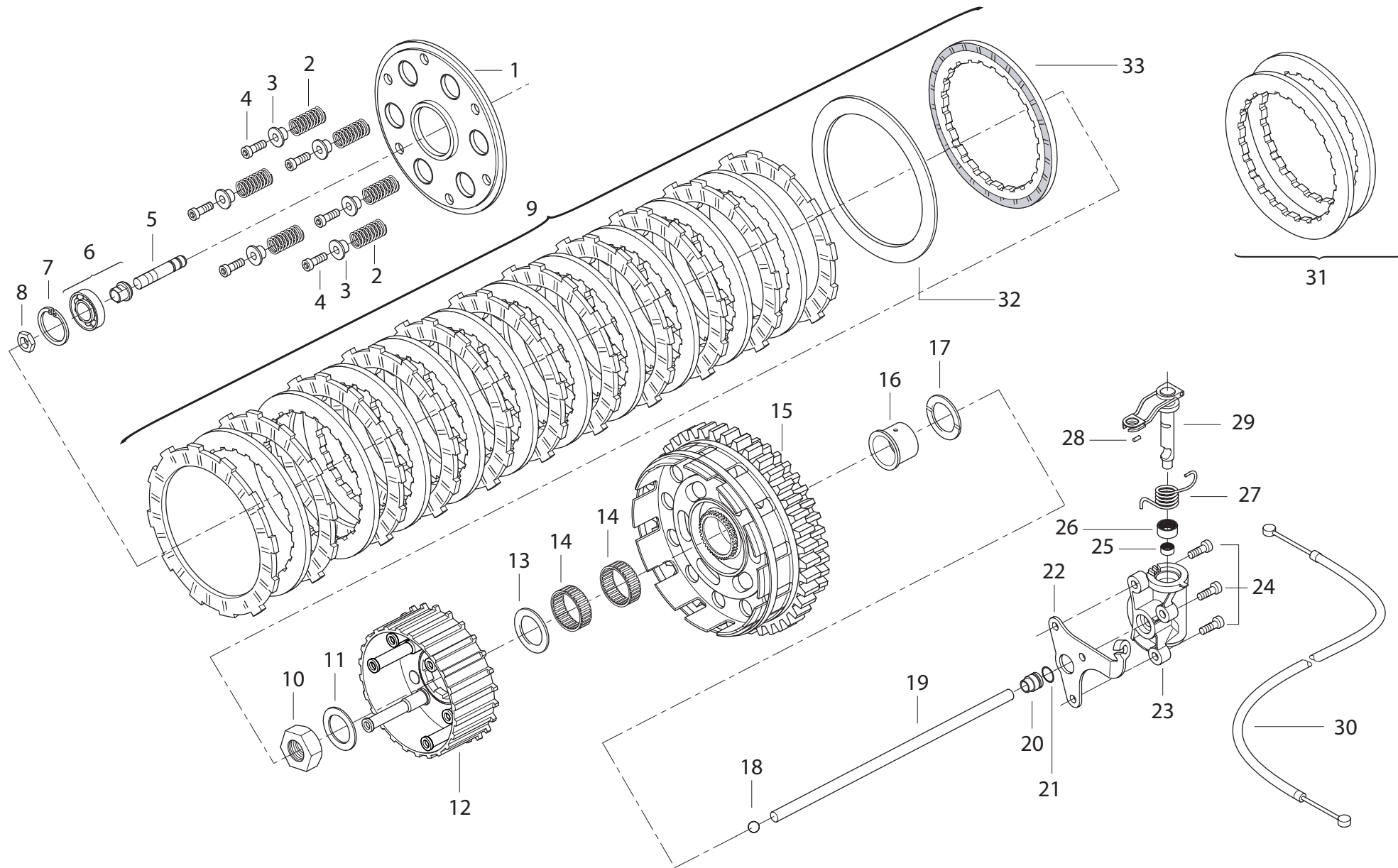

POS. NO. N. INDEX POS.	N. CODICE CODE NO. Nr. CODE ATRIKEL Nr. CODICO Nr.	DESCRIZIONE	DESCRIPTION	DESIGNATION	BEZEICHNUNG	DENOMINACION	NOTE NOTES MARKE NOTAS	Q.TA' Q.TY Q.TE M.GE C.AD	
25	R16044311A	GABBIA A RULLINI	NEEDLE BEARING	BOÎTE À AIGUILLES	NADELKÄFIG	JAULA DE RODILLOS		1	
26	R16044301A	GABBIA A RULLINI	NEEDLE BEARING	BOÎTE À AIGUILLES	NADELKÄFIG	JAULA DE RODILLOS		1	
27	R180224031000	MOLLA	SPRING	RESSORT	FEDER	MUELLE		1	
28	R92750449C	SPINA	PIN	GOUPILLE	STIFT	PASADOR		1	
29	R180224038000	COMANDO FRIZIONE	CLUTCH CONTROL	COMMANDE EMBRAYAGE	KUPPLUNGSSTEUERUNG	ACCINAMENTO EMBRAGUE		1	
30	R300065009000	CAVO FRIZIONE	CABLE ASSY CLUTCH	CÂBLE EMBRAYAGE	KUPPLUNGSKABEL	CABLE EMBRAGUE		1	
31	R180200145000	KIT DISCHI DI REGOLAZIONE	SET CLUTCH REGULATION PLATES	SÉRIE DE DISQUES RÉGLEMENT D'EMBAYAGE	SCHEIBENSATZ	SERIE DISCOS DE LA REGULACIÓN		1	
32	R180224042000	MOLLA A TAZZA	SPRING WASHER	BELLEVILLE	TELLERFEDER	ARANDELA DE MUELLE		1	
33	R180224039000	DISCO FRONTALE GUARNITO	DISC	DISQUE	HEIBE	DISCO		1	

COMANDO CAMBIO

 COMANDO CAMBIO

 GEARCHANGE

 COMMANDE
BOITE A VITESSES

 GANGSCHALTUNG

 MANDO CAMBIO

TAVOLA
DRAWING
TABLE
BILD
TABLA

011

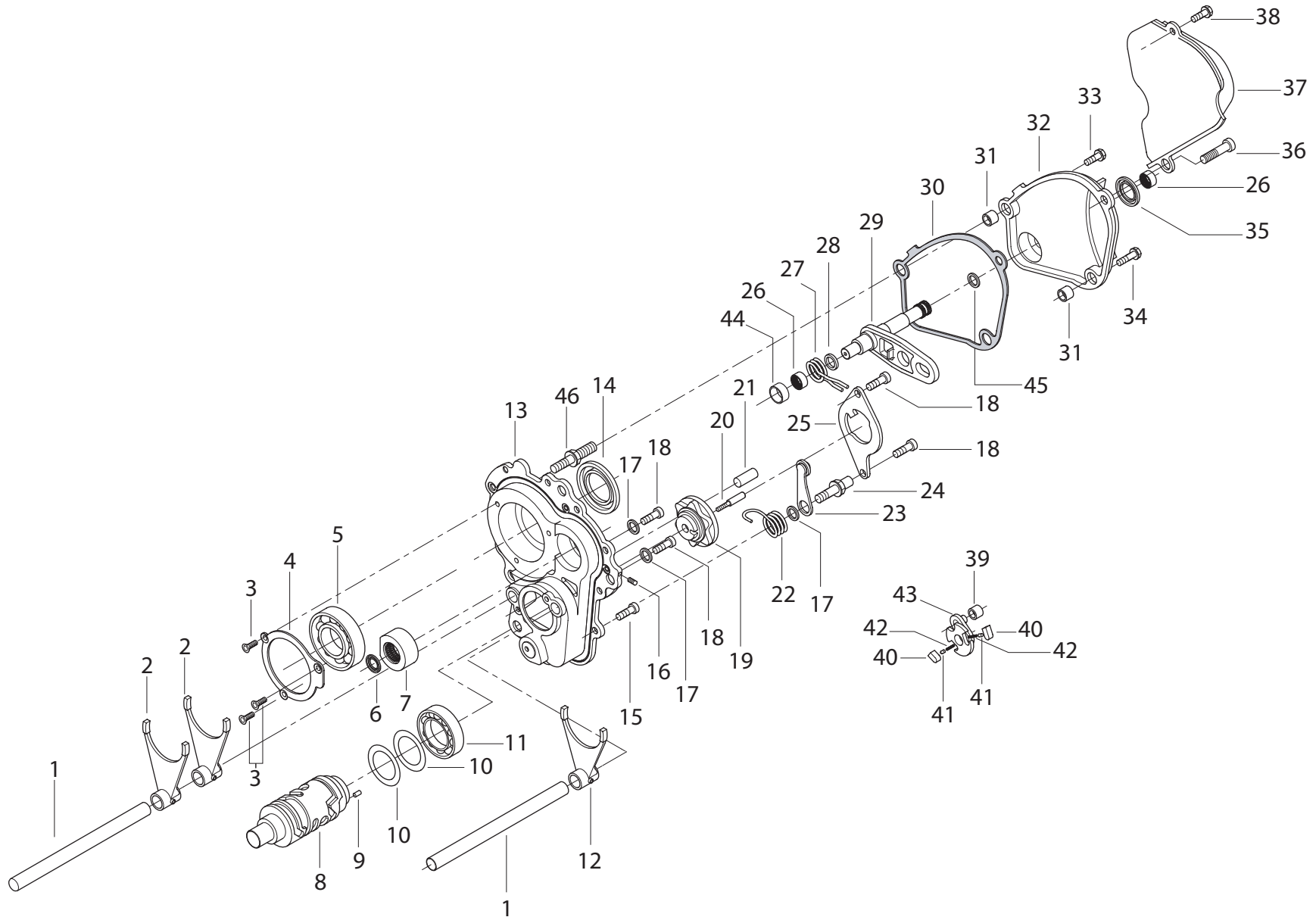

POS. NO. N. INDEX POS.	N. CODICE CODE NO. Nr. CODE ATRIKEL Nr. CODICO Nr.	DESCRIZIONE	DESCRIPTION	DESIGNATION	BEZEICHNUNG	DENOMINACION	NOTE NOTES NOTES MARKE NOTAS	Q.TA' Q.TY Q.TE M.GE C.AD	
1	R16313201A	PERNO	PIN	PIVOT	ZAPFEN	PERNO		2	
2	R16313721A	FORCELLA INNESTO MARCE 1 ^a /4 ^a -2 ^a /3 ^a	1st, 4th-2nd, 3rd GEAR SELECTOR FORK	FOURCHE ENGRÈNEMENT 1ère, 4ème-2ème, 3ème VITESSE	EINLEGEGABEL FÜR 1.,4.,-2.,3. GANG	HORQUILLA EMBRAGUE MARCHAS 1°, 4°-2°, 3°		2	
3	R90650490B	VITE	SCREW	VIS	SCHRAUBE	TORNILLO		3	
4	R16313031A	PIASTRINO	PLATE	PLAQUETTE	PLÄTTCHEN	LÁMINA		1	
5	R180202022000	CUSCINETTO	BEARING	ROULEMENT	LAGER	COJINETE		1	
6	R16343991A	ANELLO DI TENUTA	SEAL RING	BAGUE D'ÉTANCHÉITÉ	DICHTRING	ANILLO DE RETÉN		1	
7	R16344081A	CUSCINETTO	BEARING	ROULEMENT	LAGER	COJINETE		1	
8	R16314071A	DESMODROMICO	SHIFT CAM	DESMODROMIQUE	VERSCHIEBENOCKE	DESMO		1	
9	R92750649C	SPINA	PIN	GOUPILLE	STIFT	PASADOR		1	
10	R16343561A	RASAMENTO	SHIM	ROSETTE DE BUTÉE ÉPAISSEUR	DISTANZSCHEIBE STÄRKE	ARANDELA DE ESPESORACIÓN		2	
11	R16343531A	CUSCINETTO	BEARING	ROULEMENT	LAGER	COJINETE		1	
12	R16313191A	FORCELLA INNESTO MARCE 5 ^a /6 ^a	5TH, 6TH GEAR SELECTOR FORK	FOURCHE ENGRÈNEMENT 5ème, 6ème VITESSE	EINLEGEGABEL FÜR 5., 6. GANG	HORQUILLA EMBRAGUE 5°, 6°		1	
13	R180201007000	FLANGIA CAMBIO	GEAR FLANGE	BRIDE CHANGEMENT	GETRIEBEFLANSCH	ARANDELA CAMBIO		1	
14	R16343521A	ANELLO DI TENUTA	SEAL RING	BAGUE D'ÉTANCHÉITÉ	DICHTRING	ANILLO DE RÉTEN		1	
15	R90351252B	VITE	SCREW	VIS	SCHRAUBE	TORNILLO		1	
16	R14043141A	TAPPO FILETTATO	THREADED CAP	BOUCHON FILETÉE	GEWINDEVERSCLUß	TAPÓN FILETEADO		1	
17	R16313211A	RONDELLA	WASHER	RONDELLE	UNTERLEGSCHLEIBE	ARANDELA		3	
18	R90250642B	VITE	SCREW	VIS	SCHRAUBE	TORNILLO		4	
19	R16313931A	TAMBURO CAMBIO COMPLETO	COMPLETE GEARBOX DRUM	TAMBOUR COMPLET BOÎTE DE VITESSES	SCHALTROMMEL KOMPLETT	TAMBOR CAMBIO COMPLETO		1	
20	R16313081A	PERNO FISSAGGIO TAMBURO	DRUM FIXING PIN	PIVOT FIXATION TAMBOUR	BEFESTIGUNGSBOLZEN TROMMEL	PERNO FIJACIÓN TAMBOR		1	
21	R16313121A	PIOLO	PIN	PIVOT	STIFT	ESPINA		1	
22	R16313681A	MOLLA	SPRING	RESSORT	FEDER	MUELLE		1	
23	R16323221A	SALTARELLO FISSA MARCE	GEAR STOPPER	CLIQUET FIXE-VITESSES	FALLKLINKEN	TRINQUETE FIJA MARCHAS		1	
24	R16313671A	PERNO FILETTATO	THREADED PIN	PIVOT FILETÉE	GEWINDEZAPFEN	PERNO FILETEADO		1	

COMANDO CAMBIO

 COMANDO CAMBIO

 GEARCHANGE

 COMMANDE
BOITE A VITESSES

 GANGSCHALTUNG

 MANDO CAMBIO

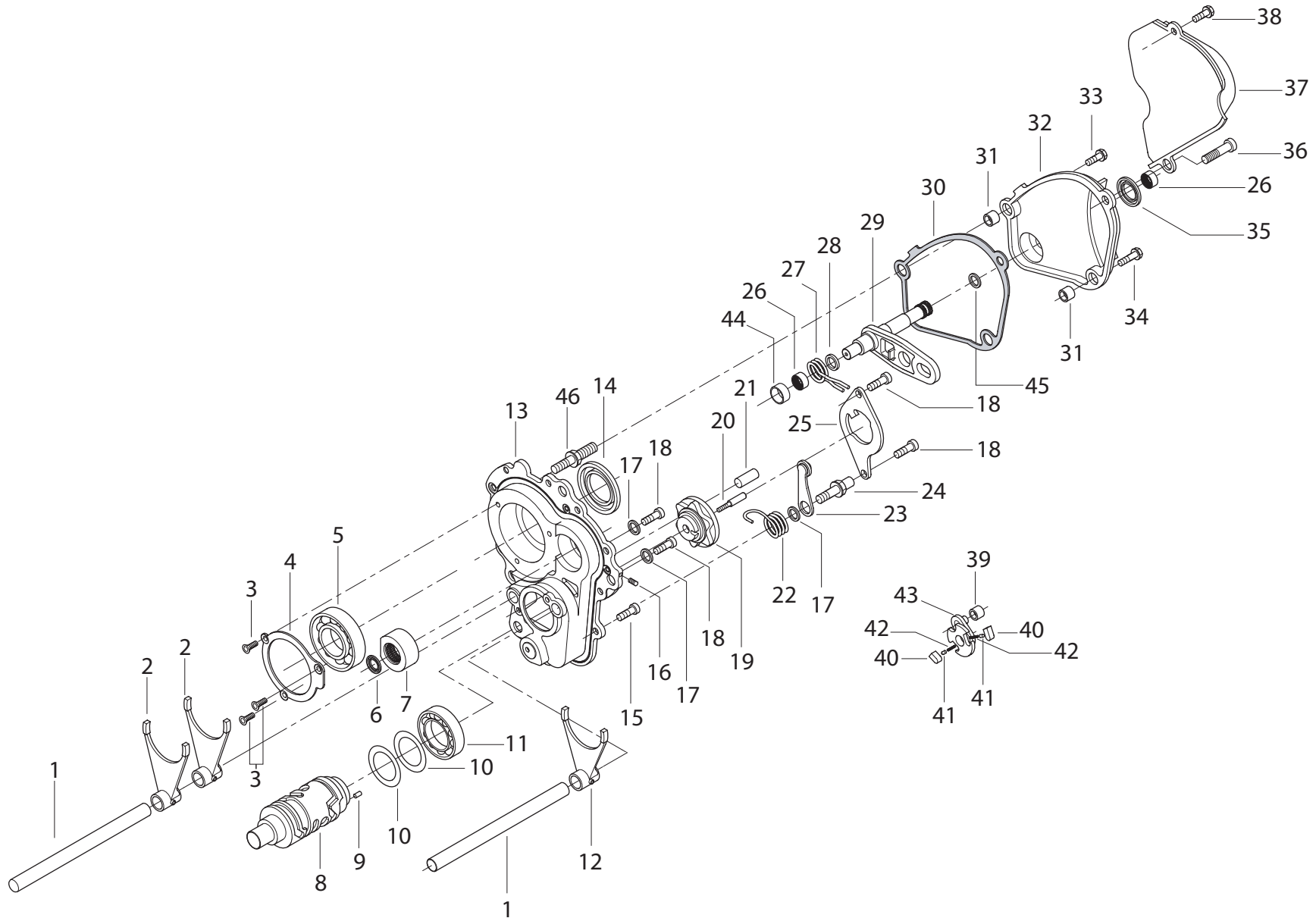

POS. NO. N. INDEX POS.	N. CODICE CODE NO. Nr. CODE ATRIKEL Nr. CODICO Nr.	DESCRIZIONE	DESCRIPTION	DESIGNATION	BEZEICHNUNG	DENOMINACION	NOTE NOTES MARKE NOTAS	Q.TA' Q.TY Q.TE M.GE C.AD	
25	R16313941A	FLANGIA	FLANGE	BRIDE	FLANSCH	BRIDA		1	
26	R180224037000	DISTANZIALE	SPACER	ENTRETOISE	DISTANZSTÜCK	DISTANCIAL		2	
27	R16313321A	MOLLA	SPRING	RESSORT	FEDER	MUELLE		1	
28	R16313461A	RONDELLA	WASHER	RONDELLE	UNTERLEGSCHIEBE	ARANDELA		1	
29	R180226002000	PERNO	PIN	PIVOT	ZAPFEN	PERNO		1	
30	R16313351A	GUARNIZIONE COPERCHIO	COVER GASKET	GARNITURE COUVERCLE	DECKELDICHUNG	JUNTA TAPA		1	
31	R16313361A	BUSSOLA	BUSH	DOUILLE	BUCHSE	CASQUILLO		2	
32	R180201008000	COPERCHIO COMANDO CAMBIO	GEAR CONTROL COVER	COUVERCLE COMMANDE CHANGEMENT	DECKEL GETRIEBESCHALTUNG	TAPA MANDO CAMBIO		1	
33	R90750652B	VITE	SCREW	VIS	SCHRAUBE	TORNILLO		1	
34	R90750672B	VITE	SCREW	VIS	SCHRAUBE	TORNILLO		1	
35	R16343611A	ANELLO DI TENUTA	SEAL RING	BAGUE D'ÉTANCHÉITÉ	DICHTRING	ANILLO DE RÉTEN		1	
36	R90351332B	VITE	SCREW	VIS	SCHRAUBE	CASQUILLO		1	
37	R180201009000	COPERCHIO PIGNONE	SPROCKET COVER	COUVERCLE PIGNON	DECKELRITZEL	TAPA PIÑÓN		1	
38	R90750692B	VITE	SCREW	VIS	SCHRAUBE	TORNILLO		1	
39	R16313171A	BOCCOLA	BUSH	DOUILLE	BUCHSE	CASQUILLO		1	
40	R16313131A	SALTARELLO ROCCHETTO	SPROCKET RATCHET	SAUTERELLE PIGNON	SPERRNOCKEN FÜR KLEINRAD	TRINQUETE PIÑÓN		2	
41	R16313141A	PIOLO	PIN	PIVOT	STIFT	ESPINA		2	
42	R16313151A	MOLLA	SPRING	RESSORT	FEDER	MUELLE		2	
43	R16323981A	ROCCHETTO DESMODROMICO	SHIFT CAM RATCHET	PIGNON DESMODROMIQUE	KLEINRAD VERSCHIEBENOCKE	ROQUETE DESMODROMICO		1	
44	R16343481A	ASTUCCIO A RULLINI	NEEDLE BEARING	ROULEMENT À ROULEAUX	NADELLAGER	COJINETE DE AGUJAS		1	
45	R180204015000	RASAMENTO	SHIM	ROSETTE DE BUTÉE ÉPAISSEUR	DISTANZSCHEIBE STÄRKE	ARANDELA DE ESPESORACIÓN		1	
46	R90752191A	VITE SPECIALE	SPECIAL SCREW	VIS SPÉCIALE	SPEZIALSCHRAUBE	TORNILLO ESPECIAL		1	

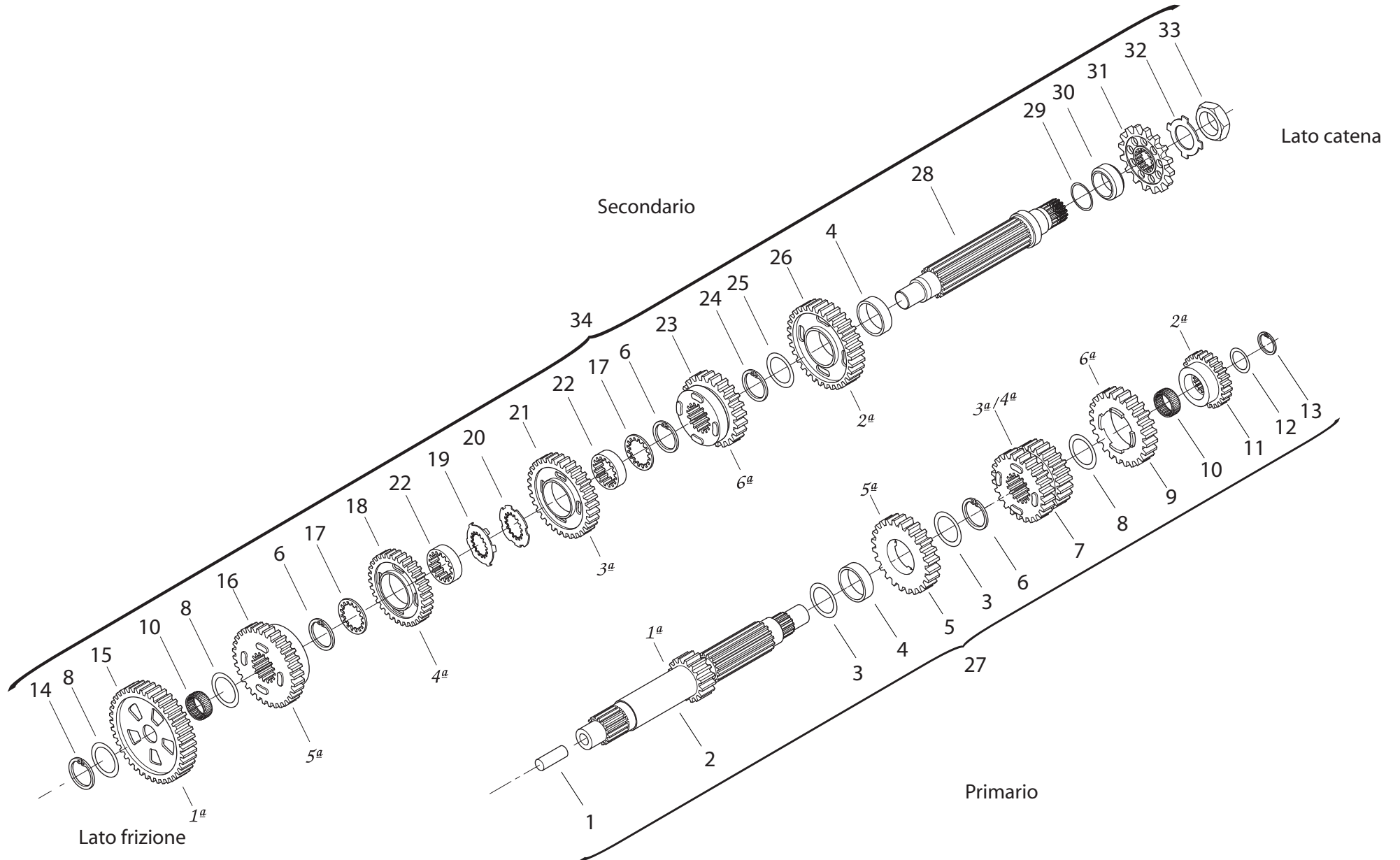

POS. NO. N. INDEX POS.	N. CODICE CODE NO. Nr. CODE ATRIKEL Nr. CODICO Nr.	DESCRIZIONE	DESCRIPTION	DESIGNATION	BEZEICHNUNG	DENOMINACION	NOTE NOTES MARKE NOTAS	Q.TA' Q.TY Q.TE M.GE C.AD	
1	R16014161A	BOCCOLA	BUSH	DOUILLE	BUCHSE	CASQUILLO		1	
2	R180224006000	ALBERO PRIMARIO Z14	MAIN SHAFT	ARBRE PRIMAIRE	HAUPTWELLE	ARBOL PRIMARIO		1	
3	R16113081A	RASAMENTO	SHIM	ROSETTE DE BUTÉE ÉPAISSEUR	DISTANZSCHEIBE STÄRKE	ARANDELA DE ESPESORACIÓN		2	
4	R300025102000	GABBIA A RULLINI	NEEDLE BEARING	BOÎTE À AIGUILLES	NADELKÄFIG	JAULA DE RODILLOS		2	
5	R16113051A	INGRANAGGIO CONDUTTORE 5° Z24	DRIVING GEAR 5th	ENGRENAGE CONDUCTEUR 5ème	ANTRIEBSZAHNRAD 5.	ENGRANAJE ACCIONADOR 5°		1	
6	R92452300D	ANELLO ELASTICO	SNAP RING	BAGUE ÉLASTIQUE	SPRENGRING	SEAGER		3	
7	R16113551A	INGRANAGGIO CONDUTTORE 3°/4°	DRIVING GEAR 3rd/4th	ENGRENAGE CONDUCTEUR 3ème/4ème	ANTRIEBSZAHNRAD 3./4.	ENGRANAJE ACCIONADOR 3°/4°		1	
8	R16113091A	RASAMENTO	SHIM	ROSETTE DE BUTÉE ÉPAISSEUR	DISTANZSCHEIBE STÄRKE	ARANDELA DE ESPESORACIÓN		3	
9	R16113061A	INGRANAGGIO CONDUTTORE 6° Z25	DRIVING GEAR 6th	ENGRENAGE CONDUCTEUR 6ème	ANTRIEBSZAHNRAD 6.	ENGRANAJE ACCIONADOR 6°		1	
10	R16143331A	GABBIA A RULLINI	NEEDLE BEARING	BOÎTE À AIGUILLES	NADELKÄFIG	JAULA DE RODILLOS		2	
11	R16113541A	INGRANAGGIO CONDUTTORE 2° Z18	DRIVING GEAR 2nd	ENGRENAGE CONDUCTEUR 2ème	ANTRIEBSZAHNRAD 2.	ENGRANAJE ACCIONADOR 2°		1	
12	R16113191A	RASAMENTO	SHIM	ROSETTE DE BUTÉE ÉPAISSEUR	DISTANZSCHEIBE STÄRKE	ARANDELA DE ESPESORACIÓN		1	
13	R92452180D	ANELLO ELASTICO	SNAP RING	BAGUE ÉLASTIQUE	SPRENGRING	SEAGER		1	
14	R92051250D	ANELLO ELASTICO	SNAP RING	BAGUE ÉLASTIQUE	SPRENGRING	SEAGER		1	
15	R180225009001	INGRANAGGIO CONDOTTO 1° Z39	DRIVEN GEAR 1st	ENGRENAGE ENTRAÎNÉ 1ère	ANGETRIEBENES ZAHNRAD 1.	ENGRANAJE CONDUCIDO 1°		1	
16	R300025006000	INGRANAGGIO CONDOTTO 5° Z28	DRIVEN GEAR 5th	ENGRENAGE ENTRAÎNÉ 5ème	ANGETRIEBENES ZAHNRAD 5.	ENGRANAJE CONDUCIDO 5°		1	
17	R16113211A	RASAMENTO BROCCIATO	BROACHED THRUST WASHER	RACLEUR BROCHE	RÄUMPASSSCHEIBE	ARANDELA RANURADA		2	
18	R300025105000	INGRANAGGIO CONDOTTO 4° Z30	DRIVEN GEAR 4th	ENGRENAGE ENTRAÎNÉ 4ème	ANGETRIEBENES ZAHNRAD 4.	ENGRANAJE CONDUCIDO 4°		1	
19	R300025107000	ANELLO DI FERMO	CHECK RING	BAGUE D' ARRÊT	SICHERUNGSRING	ANILLO DE BLOQUEO		1	
20	R300025106000	RASAMENTO BROCCIATO	BROACHED THRUST WASHER	RACLEUR BROCHE	RÄUMPASSSCHEIBE	CASQUILLO RANURADA		1	
21	R300025103000	INGRANAGGIO CONDOTTO 3° Z32	DRIVEN GEAR 3rd	ENGRENAGE ENTRAÎNÉ 3ème	ANGETRIEBENES ZAHNRAD 3.	ENGRANAJE CONDUCIDO 3°		1	
22	R300025104000	BUSSOLA BROCCIATA	BROACHED BUSH	DOUILLE BROCHÉE	RÄUMBUCHSE	ARANDELA RANURADA		2	
23	R300025007000	INGRANAGGIO CONDOTTO 6° Z27	DRIVEN GEAR 6th	ENGRENAGE ENTRAÎNÉ 6ème	ANGETRIEBENES ZAHNRAD 6.	ENGRANAJE CONDUCIDO 6°		1	
24	R92051300D	ANELLO ELASTICO	SNAP RING	BAGUE ÉLASTIQUE	SPRENGRING	SEAGER		1	

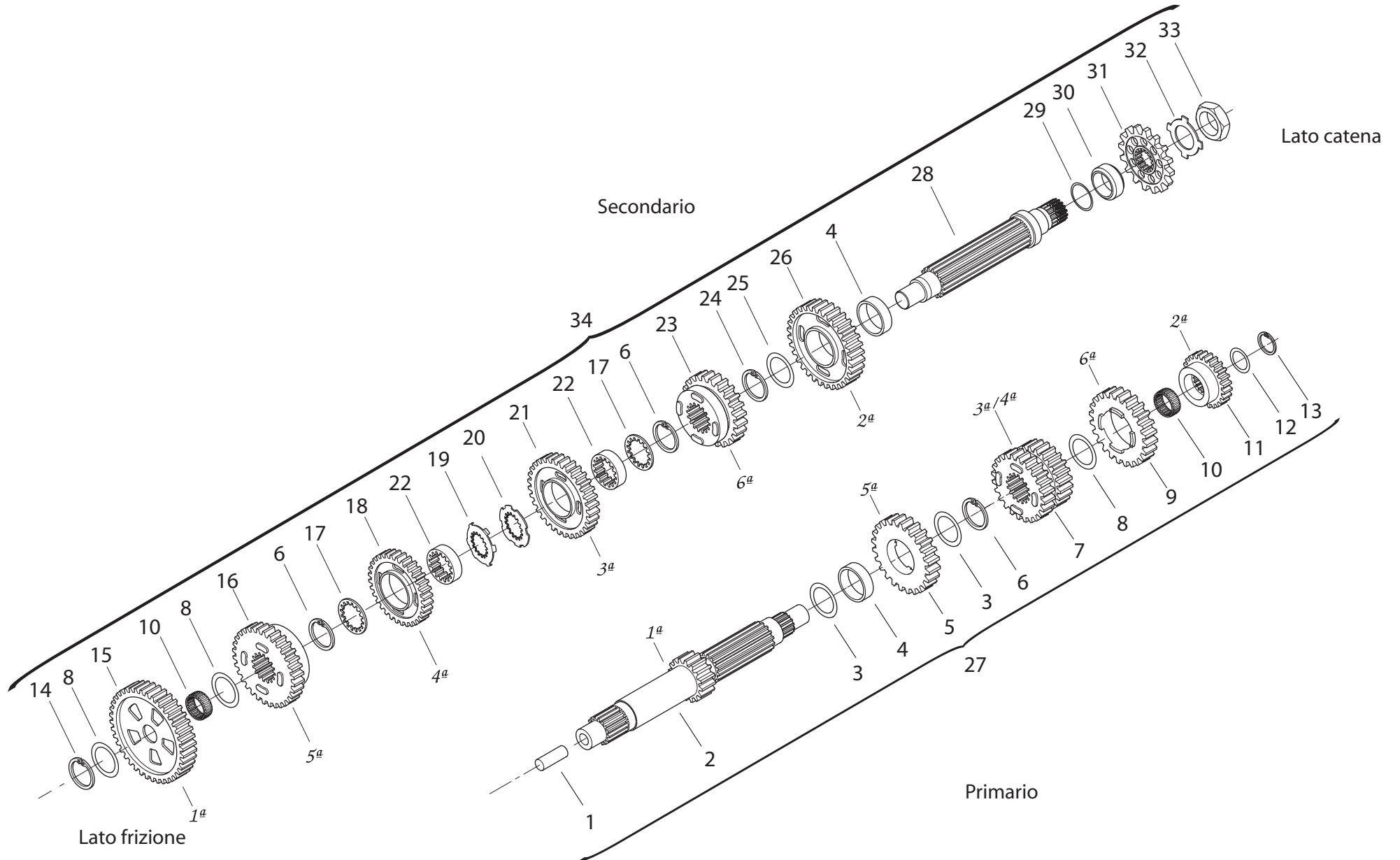

POS. NO. N. INDEX POS.	N. CODICE CODE NO. Nr. CODE ATRIKEL Nr. CODICO Nr.	DESCRIZIONE	DESCRIPTION	DESIGNATION	BEZEICHNUNG	DENOMINACION	NOTE NOTES NOTES MARKE NOTAS	Q.TA' Q.TY Q.TE M.GE C.AD	
25	R16113081A	RASAMENTO	SHIM	ROSETTE DE BUTÉE ÉPAISSEUR	DISTANZSCHEIBE STÄRKE	ARANDELA DE ESPESORACIÓN		1	
26	R180225008000	INGRANAGGIO CONDOTTO 2° Z39	DRIVEN GEAR 2nd	ENGRENAGE ENTRAÎNÉ 2ème	ANGETRIEBENES ZAHNRAD 2.	ENGRANAJE CONDUCIDO 2°		1	
27	R180224005000	ALBERO PRIMARIO COMPLETO	COMPLETE MAIN SHAFT	ARBRE PRIMAIRE COMPLET	KOMPLETTE HAUPTWELLE	ARBOL PRIMARIO COMPLETO		1	
28	R300025101000	ALBERO SECONDARIO	LAY SHAFT	ARBRE SECONDAIRE	VORGELEGEWELLE	ARBOL SECUNDARIO		1	
29	R92850019M	GUARNIZIONE OR	O-RING	JOINT D' ÉTANCHÉITÉ	DICHTUNG OR	JUNTA OR		1	
30	R16113561A	DISTANZIALE PIGNONE	SPROCKET SPACER	ENTRETOISE PIGNON	DISTANZSTÜCK RITZEL	DISTANCIADOR PIÑÓN		1	
31	R75013071A	PIGNONE Z16	SPROCKET Z16	PIGNON Z16	RITZEL Z16	PIÑÓN Z16		1	
32	R16013941A	RONDELLA	WASHER	RONDELLE	UNTERLEGSCHIEBE	ARANDELA		1	
33	R16113231A	DADO	NUT	ECROU	MUTTER	TUERCA		1	
34	R300025010000	ALBERO SECONDARIO COMPLETO	COMPLETE LAY SHAFT	ARBRE SECONDAIRE COMPLET	KOMPLETTE VORGELEGEWELLE	ARBOL SECUNDARIO COMPLETO		1	

RADIATORE ACQUA

 RADIATORE ACQUA

 WATER RADIATOR

 RADIATEUR D'EAU

 WASSERKUEHLER

 RADIATOR AGUA

TAVOLA
 DRAWING
 TABLE
 BILD
 TABLA

013

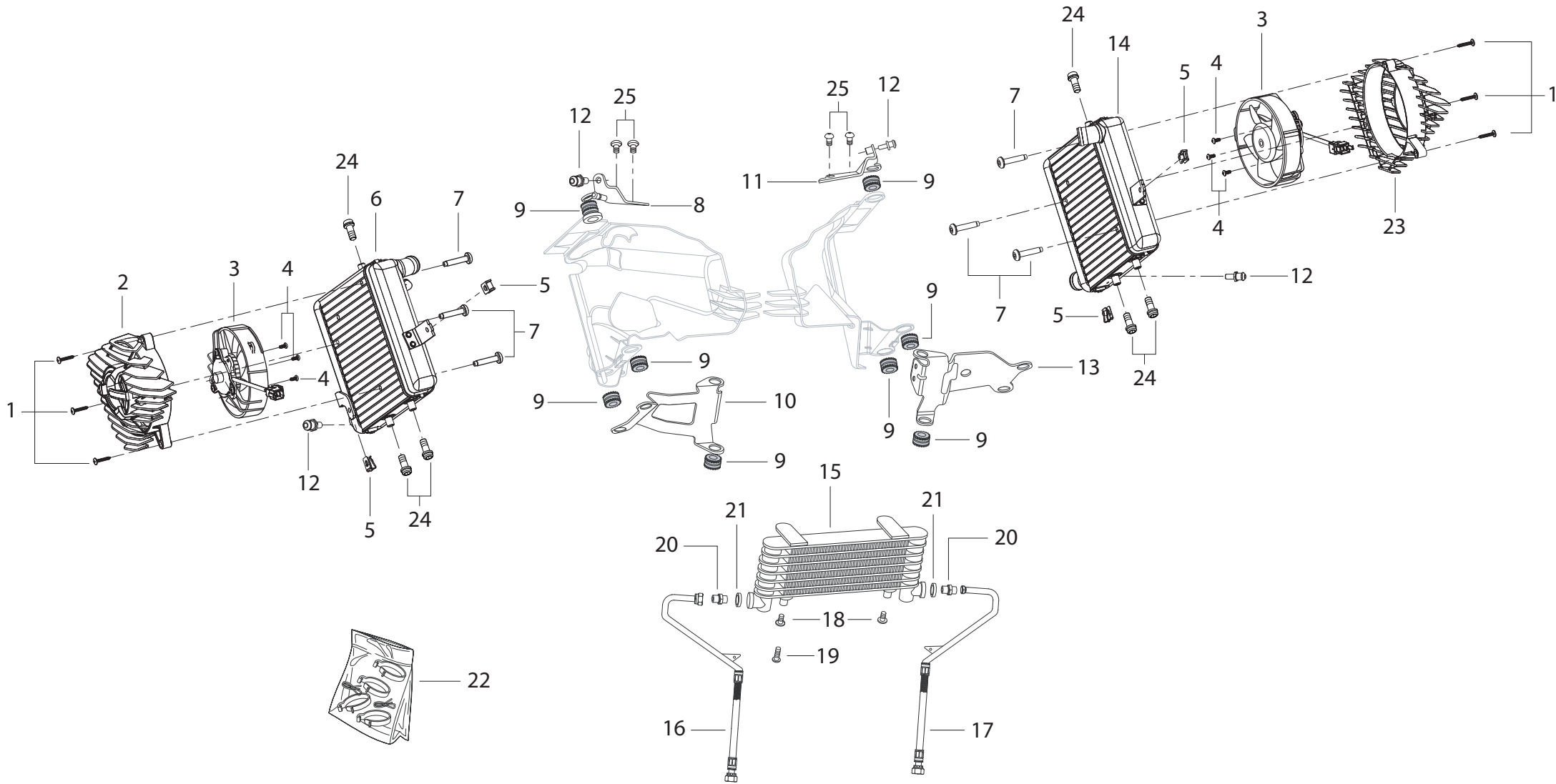

POS. NO. N. INDEX POS.	N. CODICE CODE NO. Nr. CODE ATRIKEL Nr. CODICO Nr.	DESCRIZIONE	DESCRIPTION	DESIGNATION	BEZEICHNUNG	DENOMINACION	NOTE NOTES MARKE NOTAS	Q.TA' Q.TY Q.TE M.GE C.AD	
1	R93650069E	VITE	SCREW	VIS	SCHRAUBE	TORNILLO		6	
2	R300083024000	GRIGLIA SUPPORTO VENTOLA DX	R.H. FAN HOLDER GRID	GRILLE DE SUPPORT VENTILATEUR GAUCHE	ETAGENROST HALTERUNG LÜFTERRAD RECHTS	PARILLA SOPORTE ROTOR DER.		1	
3	R300083026000	ELETTOVENTOLA	ELECTRIC FAN	ELECTRO-VENTILATEUR	ELEKTROLÜFTERRAD	ELECTROVENTILADOR		2	
4	R93054019L	VITE	SCREW	VIS	SCHRAUBE	TORNILLO		6	
5	R95050012A	CLIP	CLIP	CLIP	CLIP	CLIP		4	
6	R300083012000	RADIATORE DX	R.H. RADIATOR	RADIATOR DROITE	KÜHLER RECHTS	RADIADOR DER.		1	
7	R300052001000	PERNO FISSAGGIO SPECIALE	SPECIAL FIXING PIN	PIVOT FIXATION SPÉCIALE	SPEZIAL BEFESTIGUNG SBOLZEN	PERNO FIJACIÓN ESPECIAL		6	
8	R300057146000	SUPPORTO SUPERIORE DX	R.H. UPPER HOLDER	SUPPORT SUPÉRIEURE DROITE	HALTERUNG OBERER RECHTS	SOPORTE SUPERIOR DER.		1	
9	R180479181000	GOMMINO	RUBBER PAD	JOINT EN CAOUTCHOUC	GUMMISTÜCK	JUNTA DE GOMA		8	
10	R300057154000	SUPPORTO INFERIORE DX	R.H. LOWER HOLDER	SUPPORT INFÉRIEURE DROITE	HALTERUNG UNTERER RECHTS	SOPORTE INFERIOR DER.		1	
11	R300057155000	SUPPORTO SUPERIORE SX	L.H. UPPER HOLDER	SUPPORT SUPÉRIEURE GAUCHE	HALTERUNG OBERER LINKS	SOPORTE SUPERIOR IZQ.		1	
12	R300052003000	VITE SPECIALE	SPECIAL SCREW	VIS SPÉCIALE	SPEZIALSCHRAUBE	TORNILLO ESPECIAL		4	
13	R300057147000	SUPPORTO INFERIORE SX	L.H. LOWER HOLDER	SUPPORT INFÉRIEURE GAUCHE	HALTERUNG UNTERER LINKS	SOPORTE INFERIOR IZQ.		1	
14	R300083017000	RADIATORE SX	L.H. RADIATOR	RADIATOR GAUCHE	KÜHLER LINKS	RADIADOR IZQ.		1	
15	R300007010000	RADIATORE OLIO	OIL COOLER	RADIATOR HUILE	ÖLKÜHLER	RADIADOR ACEITE		1	
16	R300007012000	TUBO OLIO DX	R.H. OIL PIPE	CONDUITE D' HUILE DROITE	ÖLLEITUNG RECHTS?	TUBO ACEITE DER.		1	
17	R300007013000	TUBO OLIO SX	L.H. OIL PIPE	CONDUITE D' HUILE GAUCHE	ÖLLEITUNG LINKS	TUBO ACEITE IZQ.		1	
18	R90750071A	INSERTO FILETTATO	THREADED INSERT	INSERT FILETÉ	GEWINDEEINSATZ	INSERTO FILETEADO		2	
19	R90752032B	VITE	SCREW	VIS	SCHRAUBE	TORNILLO		1	
20	R180407015000	ADATTATORE	ADAPTOR	ADAPTATEUR	PASSTÜCK	ADAPTADOR		2	
21	R180407016000	GUARNIZIONE	GASKET	GARNITURE	DICHTUNG	JUNTA		2	
22	R300000172000	KIT FASCETTE	CLAMPS KIT	JEU COLLIER	KIT SCHELLE	KIT ABRAZADERA		1	
23	R300083025000	GRIGLIA SUPPORTO VENTOLA SX	L.H. FAN HOLDER GRID	GRILLE DE SUPPORT VENTILATEUR GAUCHE	ETAGENROST HALTERUNG LÜFTERRAD LINKS	PARILLA SOPORTE ROTOR IZQ.		1	
24	R90750492B	VITE	SCREW	VIS	SCHRAUBE	TORNILLO		6	

RADIATORE ACQUA

 RADIATORE ACQUA

 WATER RADIATOR

 RADIATEUR D'EAU

 WASSERKUEHLER

 RADIATOR AGUA

TAVOLA
 DRAWING
 TABLE
 BILD
 TABLA

013

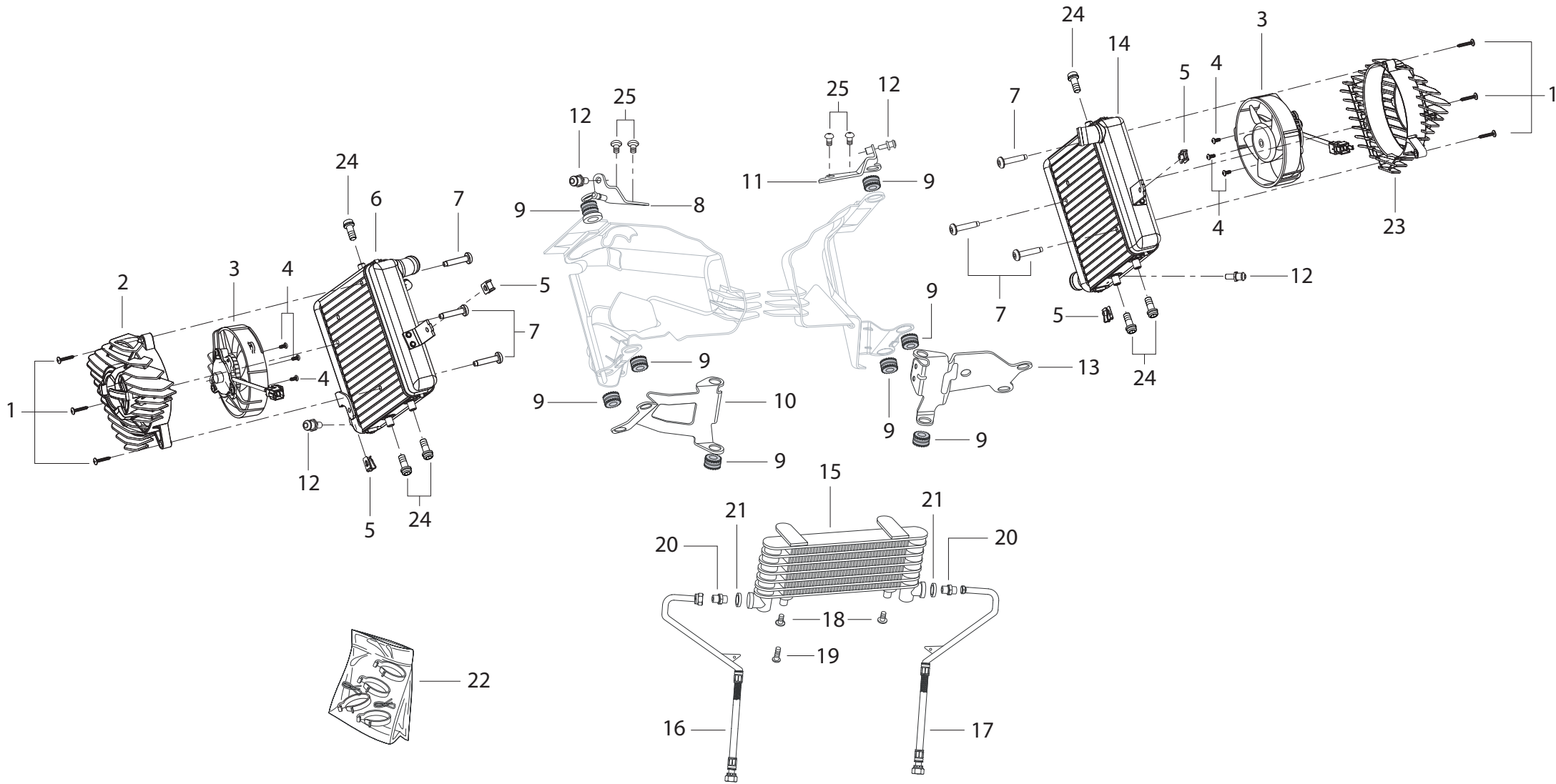

RADIATORE ACQUA



RADIATORE ACQUA



WATER RADIATOR



RADIATEUR D' EAU



WASSERKUEHLER



RADIATOR AGUA

POS. NO. N. INDEX POS.	N. CODICE CODE NO. Nr. CODE ATRIKEL Nr. CODICO Nr.	DESCRIZIONE	DESCRIPTION	DESIGNATION	BEZEICHNUNG	DENOMINACION	NOTE NOTES MARKE NOTAS	Q.TA' Q.TY Q.TE M.GE C.AD	
25	R90752292B	VITE	SCREW	VIS	SCHRAUBE	TORNILLO		4	

CIRCUITO DI RAFFREDDAMENTO

 CIRCUITO DI RAFFREDDAMENTO

 COOLING CIRCUIT

 CIRCUIT DE REFOIDISSEMENT

 KÜHLREISLAUF

 CIRCUITO REFRIGERADOR

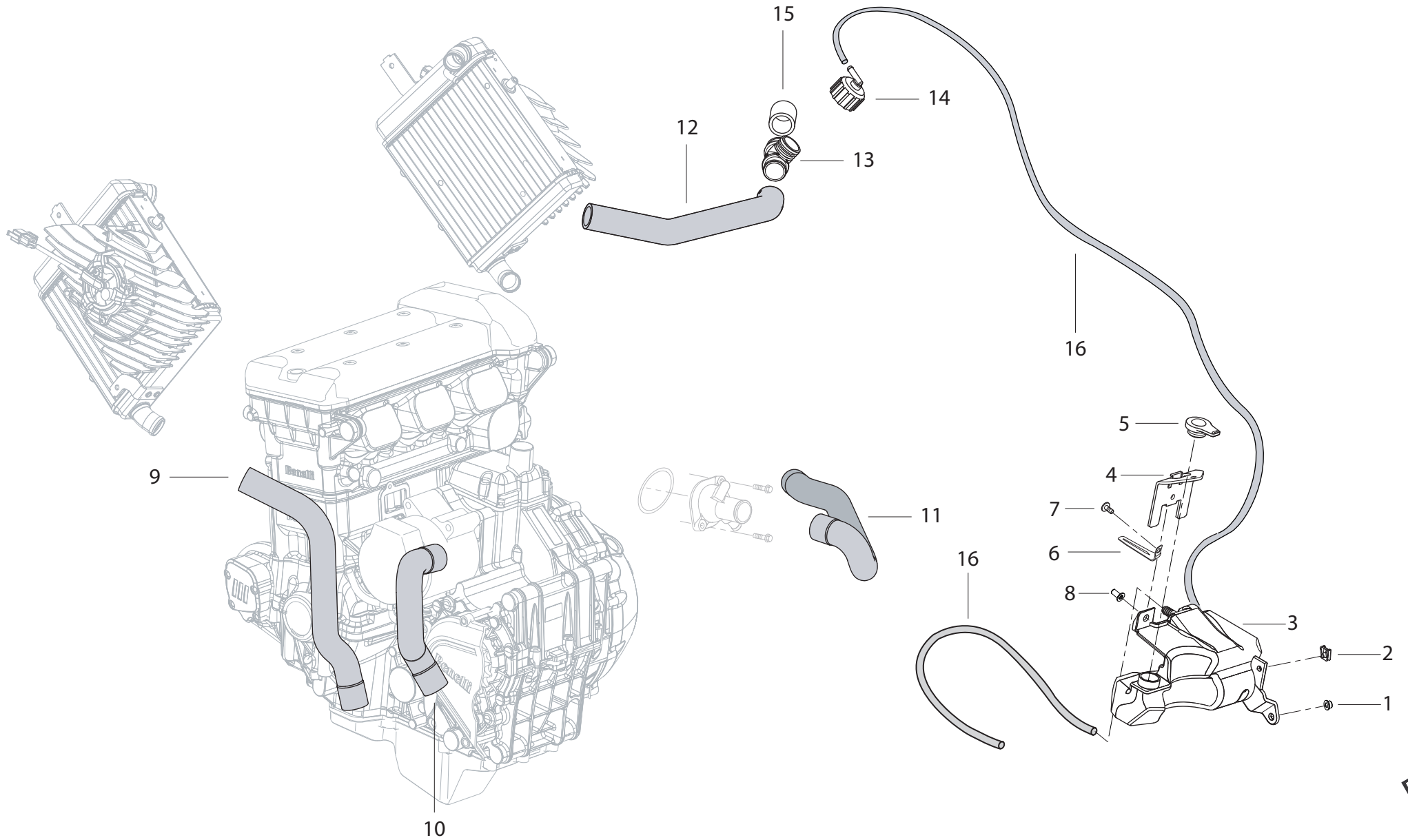

POS. NO. N. INDEX POS.	N. CODICE CODE NO. Nr. CODE ATRIKEL Nr. CODICO Nr.	DESCRIZIONE	DESCRIPTION	DESIGNATION	BEZEICHNUNG	DENOMINACION	NOTE NOTES MARKE NOTAS	Q.TA' Q.TY Q.TE M.GE C.AD	
1	R180479182000	DISTANZIALE	SPACER	ENTRETOISE	DISTANZSTÜCK	DISTANCIAL		1	
2	R95050082B	CLIP FISSAGGIO RAPIDO	QUIK FASTENING	FIXATION RAPIDE	SCHNELLEBEFESTIGUNG	FIJACIÓN RÁPIDA		1	
3	R300083007000	SERBATOIO ACQUA	WATER TANK	RÉSERVOIR D' EAU	WASSERTANK	DEPÓSITO AGUA		1	
4	R300050198000	PIASTRINO	PLATE	PLAQUETTE	PLÄTTCHEN	PLACA		1	
5	R21814511A	TAPPO SERBATOIO	TANK CAP	BOUCHON DE RÉSERVOIR	TANKVERSCHLUß	TAPÓN DEPÓSITO AGUA		1	
6	R300068105000	FASCETTA GOMMATA	RUBBERIZED CLAMP	COLLIER CHAOUTCHOUTÉ	GUMMIBESCHICHTETES SCHELLE	ABRAZADERA ENGOMADA		1	
7	R90750182B	VITE	SCREW	VIS	SCHRAUBE	TORNILLO		1	
8	R90750051A	WELL NUT	WELL NUT	WELL NUT	WELL NUT	WELL NUT		1	
9	R300083019000	TUBO ACQUA SX	L.H. WATER TUBE	TUBE D' EAU GAUCHE	WASSER ROHR LINKS	TUBO AGUA IZQ.		1	
10	R300083021000	TUBO MANDATA	DELIVERY PIPE	TUYAU DE REFOULEMENT	ROHR DRUCK	TUBO ALIMENTACIÓN		1	
11	R300083020000	TUBO ACQUA DX	R.H. WATER TUBE	TUBE D' EAU DROITE	WASSER ROHR RECHTS	TUBO AGUA DER.		1	
12	R300083022000	TUBO ACQUA SUPERIORE	UPPER WATER TUBE	TUBE D' EAU SUPÉRIEURE	WASSER ROHR OBERE	TUBO AGUA SUPERIOR		1	
13	R300083018000	BOCCHETTONE RADIATORE	RADIATOR FILLER	GOULOTTE RADIATEUR	STUTZEN KÜHLER	BOCA RADIADOR		1	
14	R300083008000	TAPPO RADIATORE ACQUA	WATER RADIATOR CAP	BOUCHON RADIATEUR D' EAU	VERSCHLUß KÜHLER WASSER	TAPÓN RADIADOR AGUA		1	
15	R300083023000	MANICOTTO	HOSE	MANCHON	MUFFE	MANGUETA		1	
16	R180183001073	MATASSA TUBO cm 74	TUBE SKEIN	ÉCHEVEAU TUBE	STRANG ROHR	MADEJA TUBO		2	

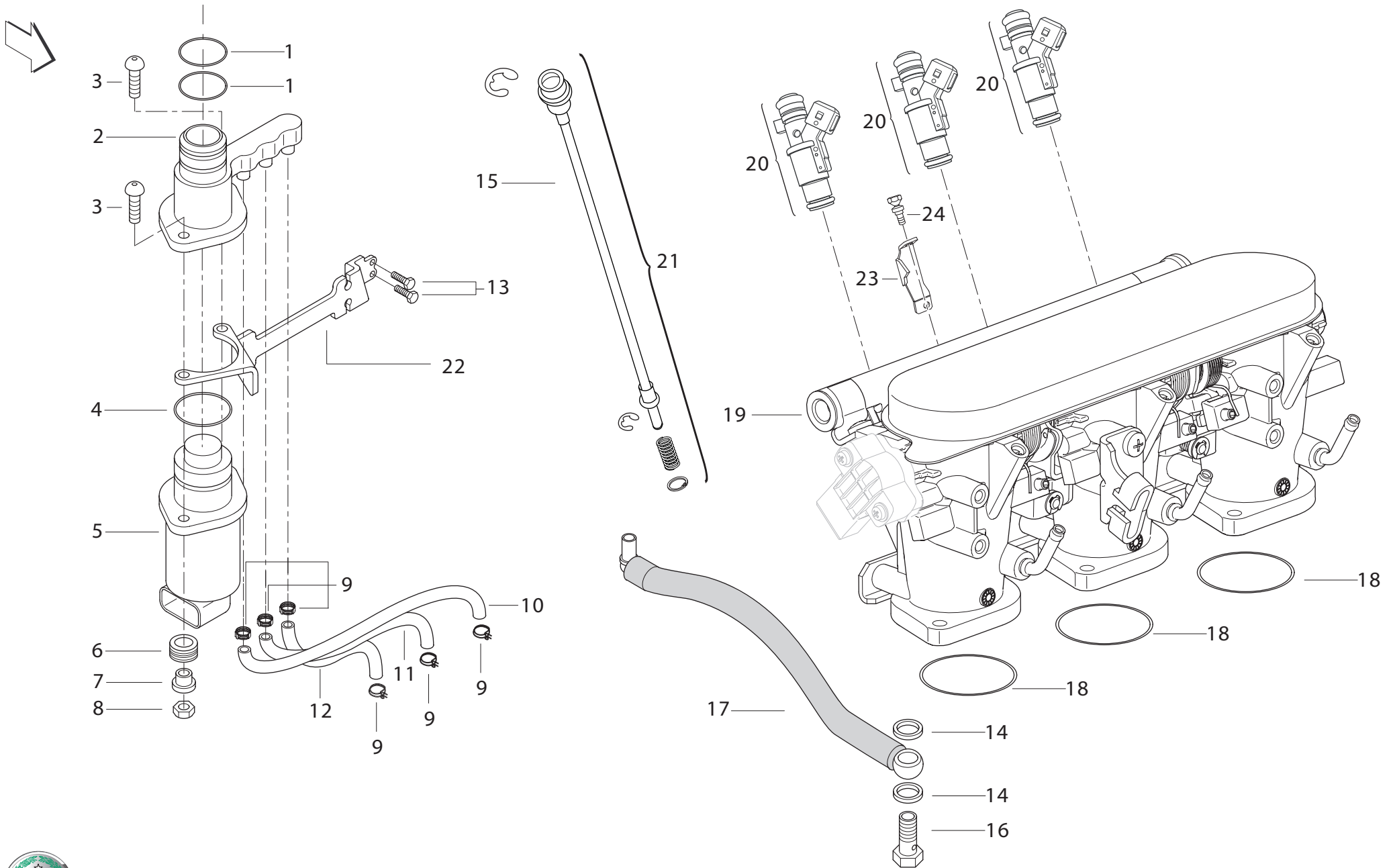

POS. NO. N. INDEX POS.	N. CODICE CODE NO. Nr. CODE ATRIKEL Nr. CODICO Nr.	DESCRIZIONE	DESCRIPTION	DESIGNATION	BEZEICHNUNG	DENOMINACION	NOTE NOTES NOTES MARKE NOTAS	Q.TA' Q.TY Q.TE M.GE C.AD	
1	R92852129M	GUARNIZIONE OR	O-RING	JOINT D' ÉTANCHÉITÉ	DICHTUNG OR	JUNTA OR		2	
2	R18324041A	DISTRIBUTORE	TIMING SYSTEM	DISTRIBUTEUR	VERTEILER	DISTRIBUIDOR		1	
3	R90450448E	VITE	SCREW	VIS	SCHRAUBE	TORNILLO		2	
4	R92850089M	GUARNIZIONE OR	O-RING	JOINT D' ÉTANCHÉITÉ	DICHTUNG OR	JUNTA OR		1	
5	R300077146000	MOTORINO PASSO PASSO	STEPPER MOTOR	MOTEUR PAS-À-PAS	SCHRITTMOTOR	MOTOR PASO PASO		1	
6	R100279118000	GOMMINO ANTIVIBRANTE	VIBRATION DAMPER PAD	JOINT EN CAOUTCHOUC ANTI-VIBRATION	SCHWINGUNGSDÄMPFERGUMMI	JUNTA DE GOMA ANTI-VIBRACIÓN		1	
7	R60110161AY	BOCCOLA	BUSH	DOUILLE	BUCHSE	CASQUILLO		1	
8	R91750022B	DADO	NUT	ECROU	MUTTER	TUERCA		1	
9	R180184001000	FASCETTA CLICK	CLAMP	COLLIER	SHELLE	ABRAZADERA		6	
10	R180190111000	TUBO ARIA MINIMO 3	3 MINIMUM AIR PIPE	TUBE AIR MINI 3	LUFTSCHLAUCH MINIMUM 3	TUBO AIRE MÍNIMO 3		1	
11	R180190110000	TUBO ARIA MINIMO 2	2 MINIMUM AIR PIPE	TUBE AIR MINI 2	LUFTSCHLAUCH MINIMUM 2	TUBO AIRE MÍNIMO 2		1	
12	R180190109000	TUBO ARIA MINIMO 1	1 MINIMUM AIR PIPE	TUBE AIR MINI 1	LUFTSCHLAUCH MINIMUM 1	TUBO AIRE MÍNIMO 1		1	
13	R90750642B	VITE	SCREW	VIS	SCHRAUBE	TORNILLO		2	
14	R18213181A	RONDELLA	WASHER	RONDELLE	UNTERLEGSCHNEIBE	ARANDELA		2	
15	R300090138000	CAVO REGOLAZIONE	CABLE FOR ADJUSTMENT	CÂBLE POUR LE RÉGLAGE	KABEL FÜR EINSTELLUNG	CABLE PARA AJUSTE		1	
16	R18343761A	RACCORDO	UNION	RACCORD	ANSCHLUß	EMPALME		1	
17	R180290109000	TUBO MANDATA BENZINA	FUEL DELIVERY PIPE	TUBE REFOULEMENT ESSENCE	BENZINZUFUHRSCHLAUCH	TUBO ENVÍO GASOLINA		1	
18	R92850059M	GUARNIZIONE OR	O-RING	JOINT D' ÉTANCHÉITÉ	DICHTUNG OR	JUNTA OR		3	
19	R18323681A	CORPO FARFALLATO	THROTTLE BODY	CORPS À PAPILLON	DROSSELKÖRPER	CUERPO MARIPOSA		1	
20	R300037016000	INIETTORE	INJECTOR	INJECTEUR	EINSPRITZDÜSE	INYECTOR		3	
21	R300090140000	KIT CAVO REGOLAZIONE	CABLE FOR ADJUSTMENT KIT	KIT CÂBLE POUR LE RÉGLAGE	KABEL FÜR EINSTELLUNGKIT	KIT CABLE PARA AJUSTE		1	
22	R21313931A	PIASTRINO SPECIALE	SPECIAL PLATE	PLAQUETTE SPÉCIALE	SPEZIALPLÄTTCHEN	LÁMINA ESPECIAL		1	
23	R300957007000	PIASTRINO	PLATE	PLAQUETTE	PLÄTTCHEN	PLACA	25 KW	1	
23	R300957008000	PIASTRINO	PLATE	PLAQUETTE	PLÄTTCHEN	PLACA	37 KW	1	

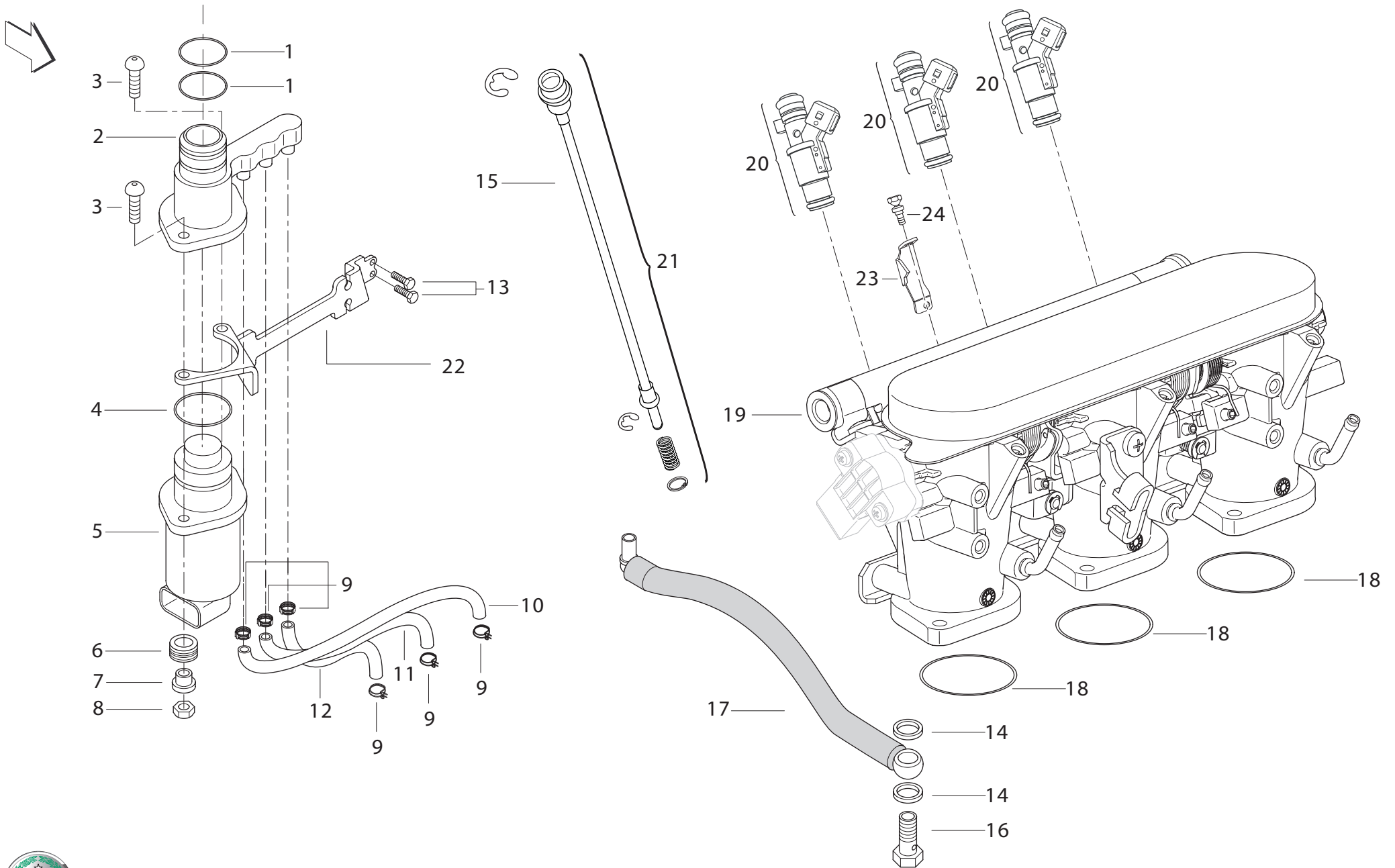

POS. NO. N. INDEX POS.	N. CODICE CODE NO. Nr. CODE ATRIKEL Nr. CODICO Nr.	DESCRIZIONE	DESCRIPTION	DESIGNATION	BEZEICHNUNG	DENOMINACION	NOTE NOTES MARKE NOTAS	Q.TA' Q.TY Q.TE M.GE C.AD	
23	R300957009000	PIASTRINO	PLATE	PLAQUETTE	PLÄTTCHEN	PLACA	72 KW	1	
23	R300957010000	PIASTRINO	PLATE	PLAQUETTE	PLÄTTCHEN	PLACA	78 KW	1	
24	R180166008000	VITE	SCREW	VIS	SCHRAUBE	TORNILLO		1	

ASPIRAZIONE

ASPIRAZIONE

INTAKE

ASPIRATION

LUFTEINZUG

ASPIRACIÓN

TAVOLA
 DRAWING
 TABLE
 BILD
 TABLA

016

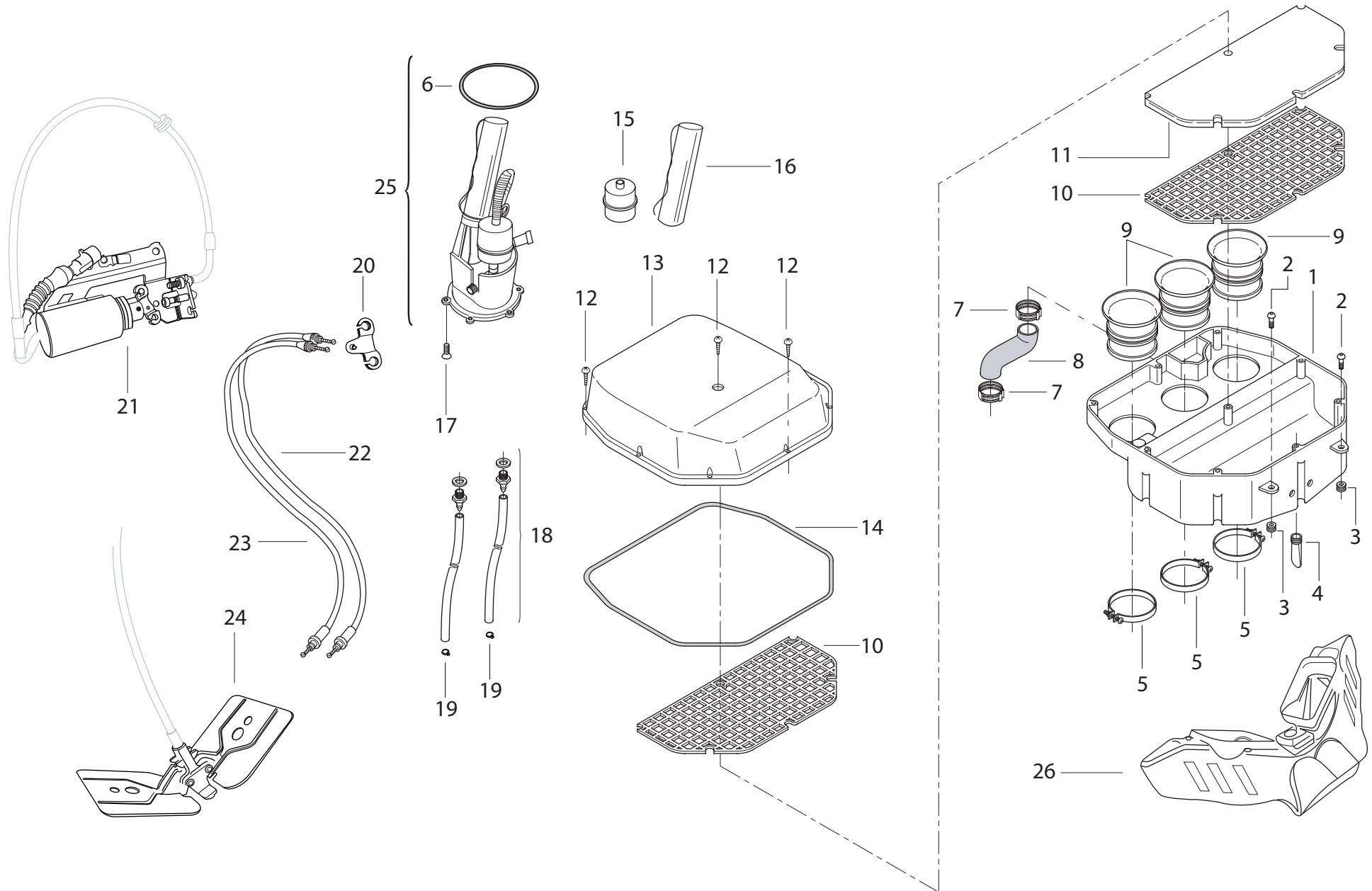

POS. NO. N. INDEX POS.	N. CODICE CODE NO. Nr. CODE ATRIKEL Nr. CODICO Nr.	DESCRIZIONE	DESCRIPTION	DESIGNATION	BEZEICHNUNG	DENOMINACION	NOTE NOTES MARKE NOTAS	Q.TA' Q.TY Q.TE M.GE C.AD	
1	R300089000000	SCATOLA FILTRO ARIA	AIR FILTER BOX	BOÎTE FILTRE À AIR	LUFILTERKASTEN	CAJA FILTRO AIRE		1	
2	R90750251A0	VITE	SCREW	VIS	SCHRAUBE	TORNILLO		2	
3	R21814461A	PASSACAVO	FAIRLEAD	PASSE-CÂBLE	KABELDURCHFÜHRUNG	PASA-CABLE		2	
4	R180190119000	GOMMINO	RUBBER PAD	JOINT EN CAOUTCHOUC	GUMMISTÜCK	JUNTA DE GOMA		1	
5	R18343751A	FASCETTA	CLAMP	COLLIER	SHELLE	ABRAZADERA		3	
6	R300090030000	ANELLO DI TENUTA	SEAL RING	BAGUE D'ÉTANCHÉITÉ	DICHTRING	ANILLO DE RETÉN		1	
7	R180184000000	FASCETTA	CLAMP	COLLIER	SHELLE	ABRAZADERA		2	
8	R180190118000	TUBO	TUBE	TUBE	ROHR	TUBO		1	
9	R18313451A	CONDOTTO ASPIRAZIONE	INTAKE DUCT	CONDUIT ASPIRATION	ANSAUGLEITUNG	TUBO ASPIRACIÓN		3	
10	R300089108000	RETE DI RITEGNO	SECURING NET	TREILLIS	HALTENETZ	RED DE RETÉN		2	
11	R21023521A	ELEMENTO FILTRANTE	FILTER ELEMENT	ELÉMENT FILTRANT	FILTERELEMENT	ELEMENTO FILTRANTE		1	
12	R90750662B	VITE	SCREW	VIS	SCHRAUBE	TORNILLO		3	
13	R300089107000	COPERCHIO SCATOLA FILTRO	FILTER CASE COVER	COUVERCLE BOÎTE FILTRE	FILTERGEHÄUSEDECKEL	TAPA CAJA FILTRO		1	
14	R21814541A	GUARNIZIONE	GASKET	GARNITURE	DICHTUNG	JUNTA		1	
15	R180100153000	KIT FILTRO BENZINA	FUEL FILTER KIT	KIT FILTRE À ESSENCE	KIT BENZINFILTER	KIT FILTRO GASOLINA		1	
16	R180190127000	SONDA LIVELLO CARBURANTE	FUEL LEVEL SENSOR	SONDE DE NIVEAU CARBURANT	KRAFTSTOFFPEGELSONDE	SONDA NIVEL COMBUSTIBLE		1	
17	R90750182B	VITE	SCREW	VIS	SCHRAUBE	TORNILLO		1	
18	R6781DDL1B	KIT TUBI	TUBES KIT	KIT TUBES	KIT ROHR	KIT TUBO		1	
19	R95251013B	FASCETTA A MOLLA	SPRING HOSE CLAMP	COLLIER À RESSORT	FEDERSHELLE	ABRAZADERA A MUELLE		2	
20	R300065012001	BILANCIERE	ROCKER	CULBUTEUR	KIPPEBEL	BILANCÍN		1	
21	R300065010001	ATTUATORE COMPLETO	COMPLETE ACTUATOR	EXECURUER COMPLET	KOMPLETTANTRIEB	ACTUADOR COMPLETO		1	
22	R300065008000	CAVO COMANDO ASPIRAZIONE	INTAKE CONTROL CABLE	CÂBLE COMMANDE ASPIRATION	STEUERKABEL ANSAUGUNG	CABLE MANDO ASPIRACIÓN		1	
23	R310065011000	CAVO COMANDO SCARICO	EXHAUST CONTROL CABLE	CÂBLE COMMANDE D' ÉCHAPPEMENT	STEUERKABEL AUSLAß	CABLE MANDO ESCAPE		1	
24	R300000171000	VALVOLA ASPIRAZIONE	INTAKE VALVE	SOUPAPE D' ASPIRATION	EINLAßVENTIL	VÁLVULA DE ASPIRACIÓN		1	

ASPIRAZIONE

 ASPIRAZIONE

 INTAKE

 ASPIRATION

 LUFTEINZUG

 ASPIRACIÓN

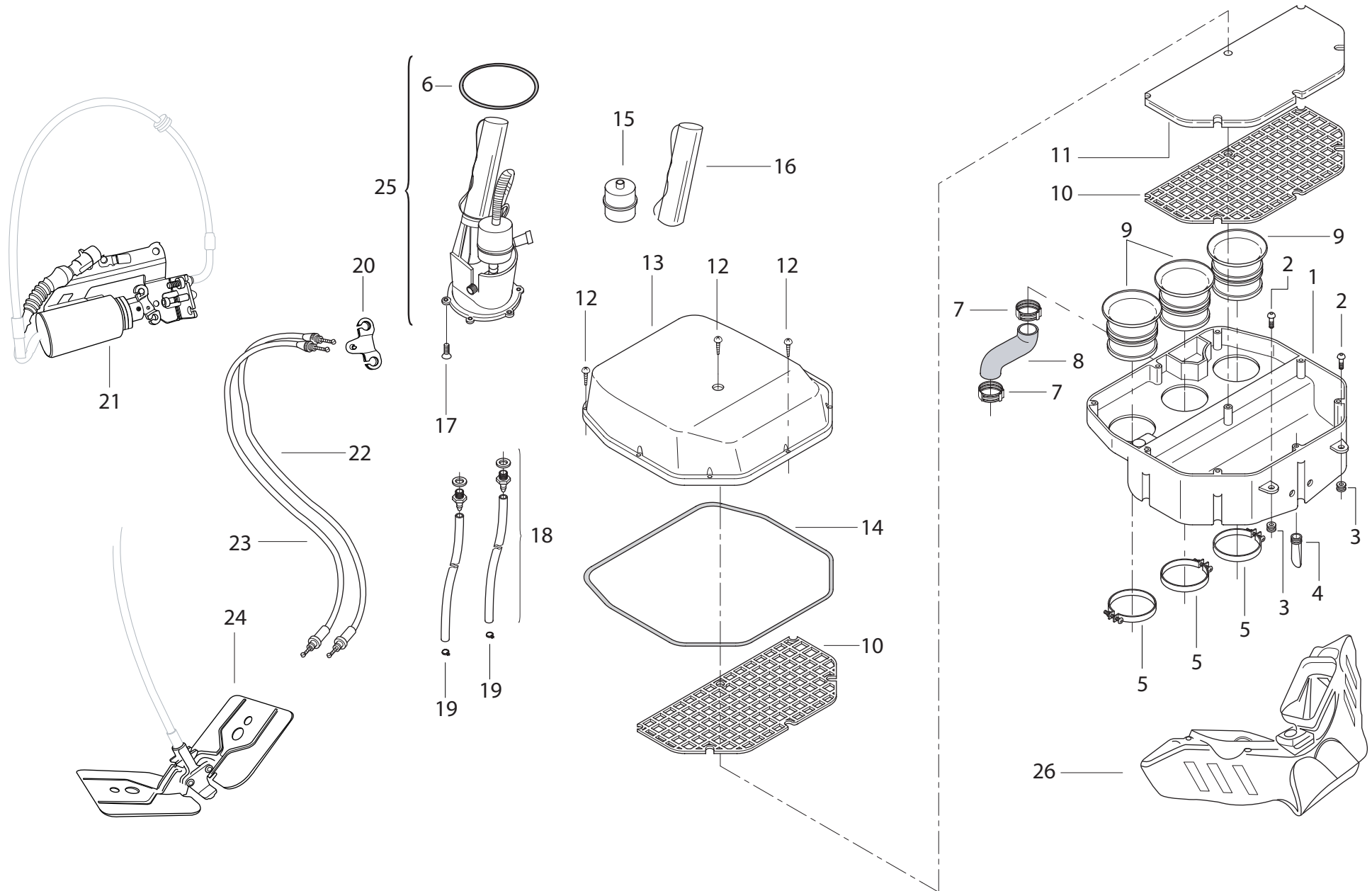

ASPIRAZIONE

INTAKE

ASPIRATION

LUFTEINZUG

ASPIRACIÓN

 TAVOLA
DRAWING
TABLE
BILD
TABLA

016

POS. NO. N. INDEX POS.	N. CODICE CODE NO. Nr. CODE ATRIKEL Nr. CODICO Nr.	DESCRIZIONE	DESCRIPTION	DESIGNATION	BEZEICHNUNG	DENOMINACION	NOTE NOTES MARKE NOTAS	Q.TA' Q.TY Q.TE M.GE C.AD	
25	R67023001A	POMPA BENZINA	FUEL PUMP	POMPE CARBURANT	BENZINPUMPE	BOMBA GASOLINA		1	
26	R300090131000	CONVOGLIATORE	MANIFOLD	CONVOYEUR	FÖRDERER	ENCANALADOR		1	

GRUPPO SCARICO

 GRUPPO SCARICO

 EXHAUST SYSTEM

 ECHAPPEMENT

 AUSPUFFANLAGE

 GRUPO ESCAPE

TAVOLA
 DRAWING
 TABLE
 BILD
 TABLA

017

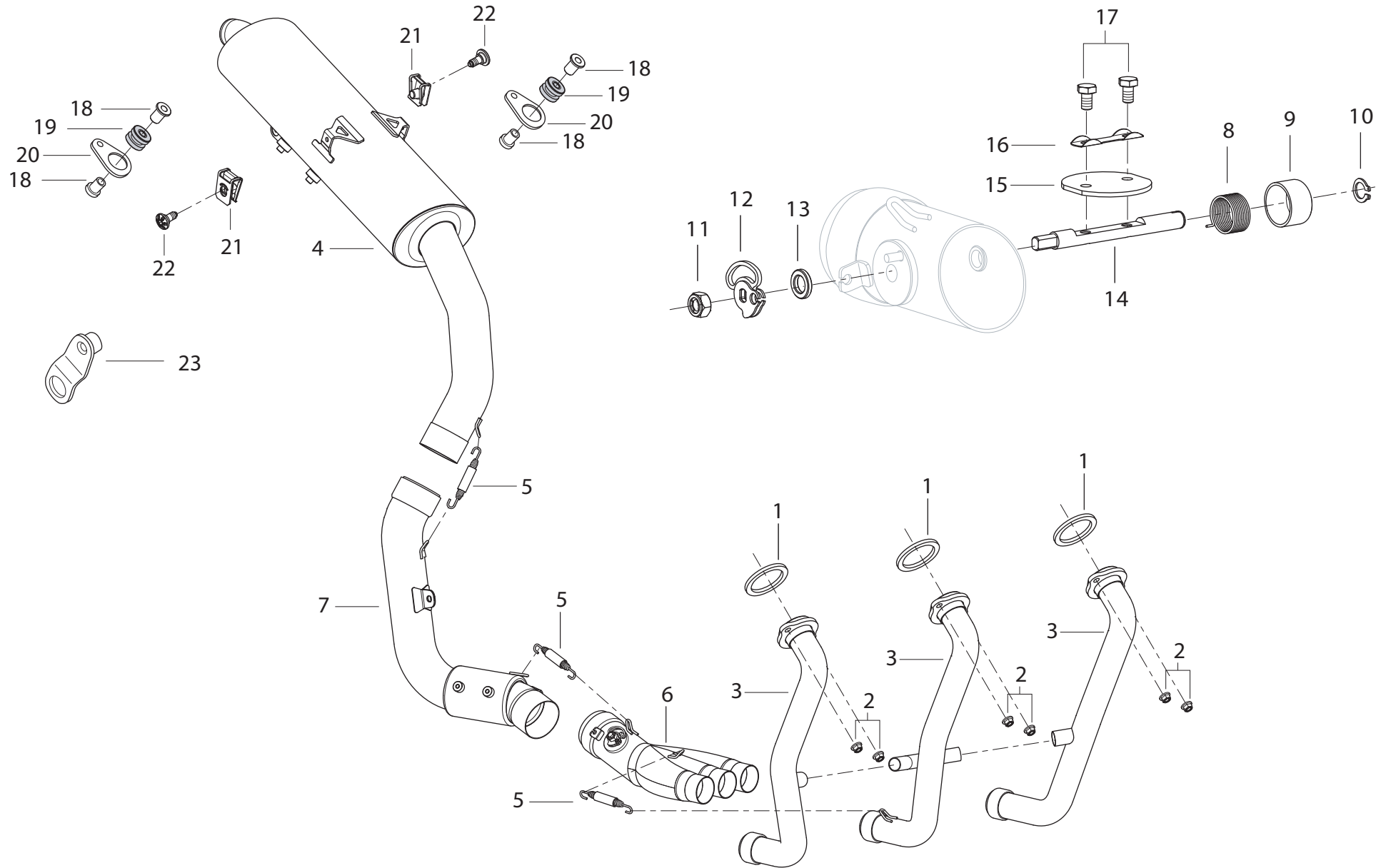

POS. NO. N. INDEX POS.	N. CODICE CODE NO. Nr. CODE ATRIKEL Nr. CODICO Nr.	DESCRIZIONE	DESCRIPTION	DESIGNATION	BEZEICHNUNG	DENOMINACION	NOTE NOTES NOTES MARKE NOTAS	Q.TA' Q.TY Q.TE M.GE C.AD	
1	R14113131A	GUARNIZIONE SCARICO	EXHAUST GASKET	JOINT DE DÉCHARGE	AUSPUFFDICHTUNG	JUNTA ESCAPE		3	
2	R91350082B	DADO	NUT	ECROU	MUTTER	TUERCA		6	
3	R300086013000	COLLETTORE DI SCARICO	EXHAUST MANIFOLD	COLLECTEUR D'ÉCHAPPEMENT	AUSPUFFKRÜMMER	COLECTOR DE ESCAPE		3	
4	R300086102000	SILENZIATORE	SILENCER	SILENCIEUX	SCHALLDÄMPFER	SILENCIADOR		1	
5	R180286011001	MOLLA	SPRING	RESSORT	FEDER	MUELLE		3	
6	R300086007000	COLLETTORE DI SCARICO (TRE IN UNO)	EXHAUST MANIFOLD (THREE IN ONE)	COLLECTEUR D'ÉCHAPPEMENT (TROIS DANS UN)	AUSPUFFKRÜMMER (DREI IN EINS)	COLECTOR DE ESCAPE (TRES EN UNO)		1	
7	R300486135000	RACCORDO COLLETTORE DI SCARICO	CONNECTION COLLECTOR	COLLECTEUR DE RACCORDEMENT	ANSCHLUSS-AUSPUFFKRÜMMER	COLECTOR DE ESCAPE DE LA CONEXIÓN	KAT	1	
8	R300086127000	MOLLA	SPRING	RESSORT	FEDER	MUELLE		1	
9	R3000861260000	TAPPO VALVOLA SCARICO	EXHAUST VALVE CAP	BOUCHON SOUPAPE D'ÉCHAPPEMENT	VERSCHLUß-AUSLABVENTIL	TAPÓN VÁLVULA DE DESCARGA		1	
10	R92450108E	ANELLO ELASTICO	SNAP RING	BAGUE ELASTIQUE	SPRENGRING	SEAGER		1	
11	R91750058E	DADO	NUT	ECROU	MUTTER	TUERCA		1	
12	R300086128000	FLANGIA VALVOLA DI SCARICO	EXHAUST VALVE FLANGE	BRIDE DE SOUPAPE D'ÉCHAPPEMENT	AUSLABVENTIL-FLANSCH	BRIDA VÁLVULA DE DESCARGA		1	
13	R90753002B	RONDELLA	WASHER	RONDELLE	UNTERLEGSCHIEBE	ARANDELA		1	
14	R300086125000	ALBERINO VALVOLA DI SCARICO	EXHAUST MAIN SHAFT	PIVOT DE SOUPAPE D'ÉCHAPPEMENT	ZAPFEN-AUSLABVENTIL	ÁRBOL LA VÁLVULA DE DESCARGA		1	
15	R300086123000	VALVOLA DI SCARICO	EXHAUST VALVE	SOUPAPE D'ÉCHAPPEMENT	AUSLABVENTIL	VÁLVULA DE DESCARGA		1	
16	R300086137000	PIASTRINA	PLATE	PLAQUETTE	PLÄTTCHEN	PLACA		1	
17	R90150628E	VITE	SCREW	VIS	SCHRAUBE	TORNILLO		2	
18	R300079186000	BOCCOLA	BUSH	DOUILLE	BUCHSE	CASQUILLO		4	
19	R180479181000	GOMMINO	RUBBER PAD	BJOINT EN CAOUTCHOUC	GUMMISTÜCK	JUNTA DE GOMA		2	
20	R300086134000	BIELLETTA SILENZIATORE	SILENCER CONNECTING ROD	BIELLETTTE SILENCIEUX	PLEUELSTANGE AUSPUFFTOPF	BIELA SILENCIADOR		2	
21	R95050012A	CLIP FISSAGGIO RAPIDO	QUIK FASTENING	FIXATION RAPIDE	SCHNELLEBEFESTIGUNG	FIJACIÓN RÁPIDA		2	
22	R90750522B	VITE	SCREW	VIS	SCHRAUBE	TORNILLO		2	
23	R300086133000	SUPPORTO MARMITTA	EXHAUST BOX HOLDER	SUPPORT POT	HALTERUNG AUSPUFFTOPF	SOPORTE SILENCIADOR		1	

IMPIANTO ELETTRICO

 IMPIANTO ELETTRICO

 ELECTRIC SYSTEM

 INSTALLATION
ELECTRIQUE

 ELEKTRISCHE
ANLAGE

 SISTEMA ELECTRICO

TAVOLA
DRAWING
TABLE
BILD
TABLA

018

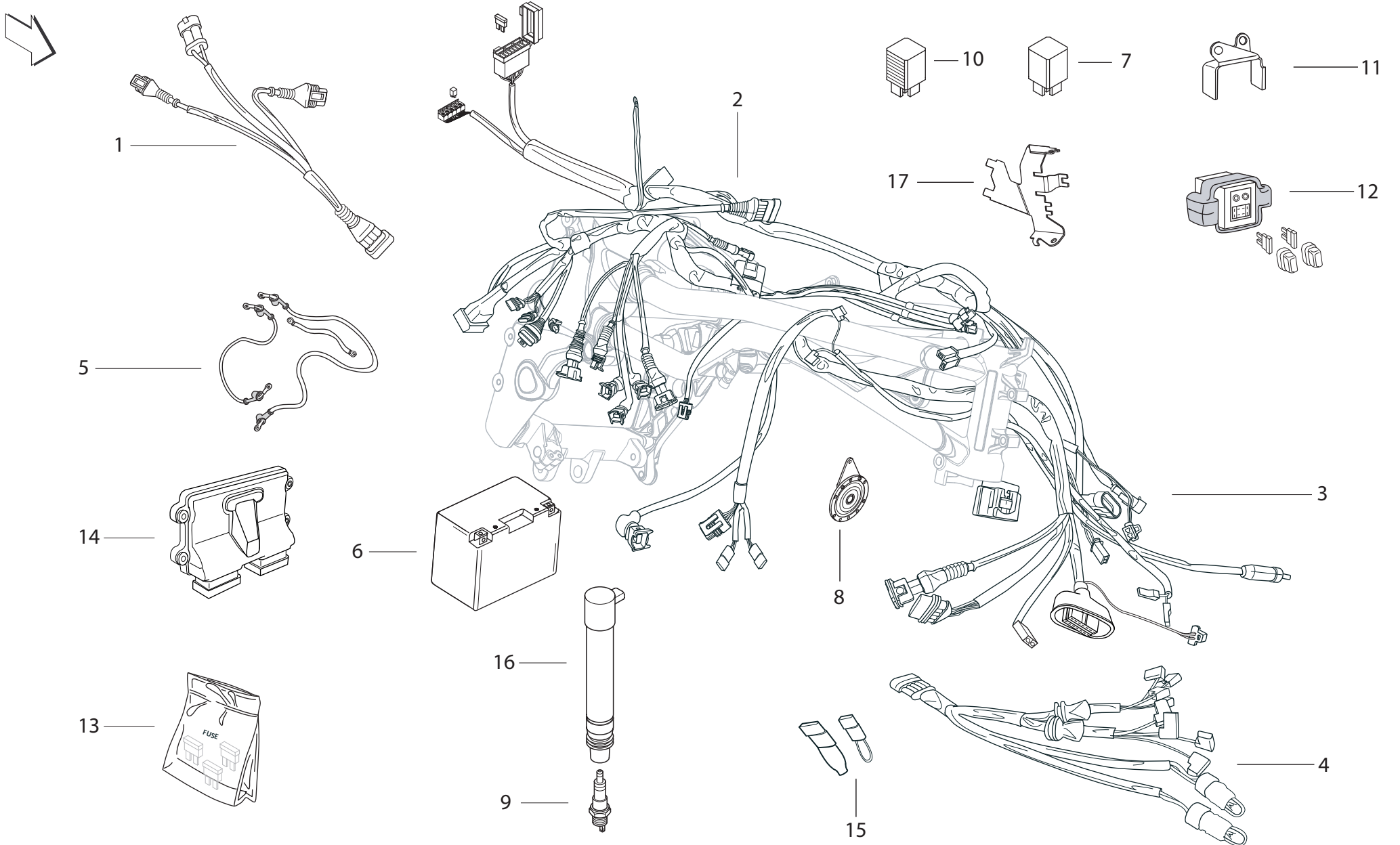



IMPIANTO ELETTRICO



ELECTRIC SYSTEM



INSTALLATION
ELECTRIQUE



ELEKTRISCHE
ANLAGE



SISTEMA ELECTRICO

POS. NO. N. INDEX POS.	N. CODICE CODE NO. Nr. CODE ATRIKEL Nr. CODICO Nr.	DESCRIZIONE	DESCRIPTION	DESIGNATION	BEZEICHNUNG	DENOMINACION	NOTE NOTES NOTES MARKE NOTAS	Q.TA' Q.TY Q.TE M.GE C.AD	
1	R300077135000	CABLAGGIO POSTERIORE	REAR WIRING	CÂBLAGE ARRIÈRE	HINTERER VERKABELUNG	CABLEADO TRASERO		1	
2	R300077107000	CABLAGGIO SERVIZI	SERVICE WIRING	CÂBLAGE SERVICE	VERKABELUM DIENST	CABLEADO SERVICIOS		1	
3	R300977119000	CABLAGGIO INIEZIONE	INJECTION WIRING	INJECTEUR CÂBLAGE	VERKABELUNG EINSPRITZDÜSE	CABLEADO INYECTOR		1	
4	R300077101001	CABLAGGIO ANTERIORE	FRONT WIRING	CÂBLAGE AVANT	VORDERES VERKABELUNG	CABLEADO DELANTERO		1	
5	R300077104001	CABLAGGIO BATTERIA	BATTERY WIRING	CÂBLAGE BATTERIE	VERKABELUNG BATTERIE	CABLEADO BATERÍA		1	
6	R300077100000	BATTERIA	BATTERY	BATTERIE	BATTERIE	BATERÍA		1	
7	R51890211A0	INTERMITTENZA	INTERMITTENTLY	INTERMITTENCE	INTERMITTENZ	IINTERMITENTE		1	
8	R180277105000	AVVISATORE ACUSTICO	HORN	KLAXON	HUPE	CLAXON		1	
9	R290033100000	CANDELA	SPARK PLUG	BOUGIE	ZÜNDKERZE	BUJIA		1	
10	R180177125000	RELAIS	RELAY	RELAIS	RELAIS	RELÉ		1	
11	R180157134000	PIASTRINO	PLATE	PLAQUETTE	PLÄTTCHEN	LÁMINA		1	
12	R180177122000	RELAIS	RELAY	RELAIS	RELAIS	RELÉ		1	
13	R180100136000	KIT FUSIBILI	FUSE KIT	KIT FUSIBLE	KIT SICHERUNG	KIT FUSIBLE		1	
14	R300077139000	CENTRALINA INIEZIONE	INJECTION CONTROL UNIT	CENTRALE INJECTION	STEUERGEHÄUSE DER EINSPRITZUNG	CENTRALITA INYECCIÓN		1	
15	R300077149000	DIODO	DIODE	DIODE	DIODE	DIODO		1	
16	R500033012000	BOBINA	COIL	BOBINE	ZÜNDSPULE	BOBINA		1	
17	R300057161000	PIASTRINO	PLATE	PLAQUETTE	PLÄTTCHEN	LÁMINA		1	

AVVIAMENTO ELETTRICO

 AVVIAMENTO ELETTRICO

 ELECTRIC STARTER

 DEMARRAGE ELECTRONIQUE

 ELEKTROSTARTER ANLASSER

 PUESTA EN MARCHA ELECTRICA

TAVOLA
 DRAWING
 TABLE
 BILD
 TABLA

019

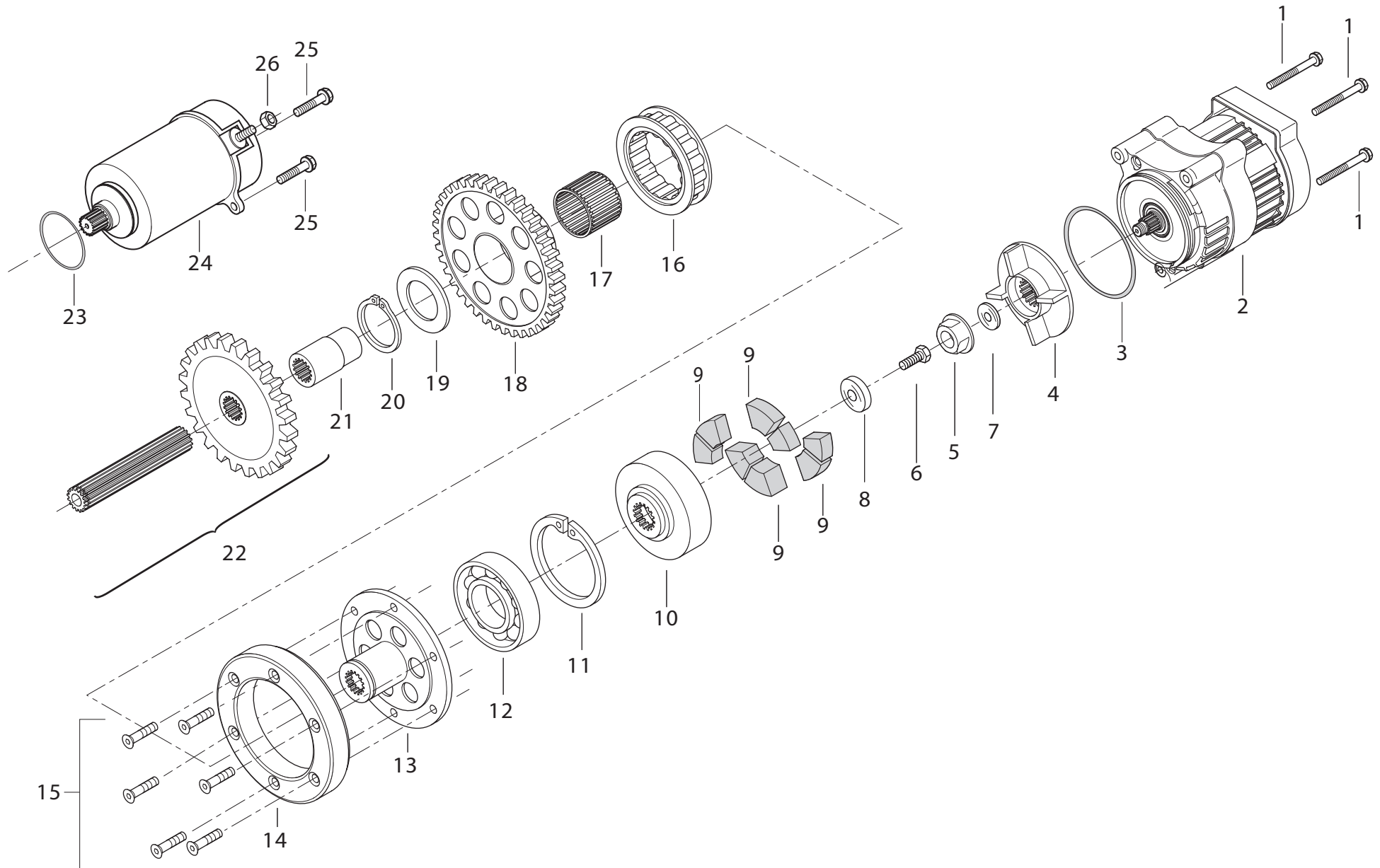

POS. NO. INDEX POS.	N. CODICE CODE NO. Nr. CODE ATRIKEL Nr. CODICO Nr.	DESCRIZIONE	DESCRIPTION	DESIGNATION	BEZEICHNUNG	DENOMINACION	NOTE NOTES NOTES MARKE NOTAS	Q.TA' Q.TY Q.TE M.GE C.AD	
1	R90751342B	VITE	SCREW	VIS	SCHRAUBE	TORNILLO		3	
2	R18243011A	ALTERNATORE	GENERATOR	ALTERNATEUR	DREHSTOMGENERATOR	ALTERNADOR		1	
3	R18243091A	GUARNIZIONE OR	O-RING	JOINT D'ÉTANCHÉITÉ	DICHTUNG OR	JUNTA OR		1	
4	R19113071A	GIUNTO MASCHIO	MALE COUPLING	JOINT MÂLE	VERBINDUNGSKUPPLUNG MÄNNLICH	JUNTA MACHO		1	
5	R19143251A	DADO	NUT	ECROU	MUTTER	TUERCA		1	
6	R90752751C	VITE	SCREW	VIS	SCHRAUBE	TORNILLO		1	
7	R310032008000	RONDELLA	WASHER	RONDELLE	UNTERLEGSCHIEBE	ARANDELA		1	
8	R310032007000	RONDELLA SPECIALE	SPECIAL WASHER	RONDELLE SPÉCIALE	SPEZIALUNTERLEGSCHIEBE	ARANDELA ESPECIAL		1	
9	R19113191A	GOMMA PARASTRAPPI	SPRING DRIVE RUBBER	CAOUTCHOUC FLECTEUR	STOESSSCHUTZGUMMI	GOMA JUNTA AMORTIGÜADORA		4	
10	R180232109000	GIUNTO FEMMINA	FEMALE COUPLING	FEMELLE JOINT	VERBINDUNGSKUPPLUNG-FRAU	JUNTA-HEMBRA		1	
11	R92550470D	ANELLO ELASTICO	SNAP RING	BAGUE ÉLASTIQUE	SPRENGRING	SEAGER		1	
12	R11043441A	CUSCINETTO	BEARING	ROULEMENT	LAGER	COJINETE		1	
13	R19113291A	MOZZO RUOTA LIBERA	SPRAG CLUTCH HUB	MOYEU POUR ROUE LIBRE	FREILAUFNABE	CUBO RUEDA LIBRE		1	
14	R19113281A	FLANGIA	FLANGE	BRIDE	FLANSCH	BRIDA		1	
15	R90650520C	VITE	SCREW	VIS	SCHRAUBE	TORNILLO		6	
16	R19143141A	RUOTA LIBERA	STARTER CLUTCH	ROUE LIBRE	FREILAUF	RUEDA LIBRE		1	
17	R19143211A	GABBIA A RULLINI	NEEDLE BEARING	BOÎTE À AIGUILLES	NADELKÄFIG	JAULA DE RODILLOS		1	
18	R19113111A	INGRANAGGIO RUOTA LIBERA Z60	SPRAG CLUTCH GEAR	ENGRENAGE ROUE LIBRE	ZAHNRAD FÜR FREILAUF	ENGRANAJE CUBO RUEDA LIBRE		1	
19	R19113131A	DISTANZIALE	SPACER	ENTRETOISE	DISTANZSTÜCK	DISTANCIAL		1	
20	R92450280D	ANELLO ELASTICO	SNAP RING	BAGUE ÉLASTIQUE	SPRENGRING	SEAGER		1	
21	R19113061A	DISTANZIALE	SPACER	ENTRETOISE	DISTANZSTÜCK	DISTANCIAL		1	
22	R300000081000	KIT INGRANAGGI	GEAR KIT	KIT ENGRENAGE	KIT ZAHNRAD	KIT ENGRANAJE		1	
23	R180134001000	GUARNIZIONE OR	O-RING	JOINT D'ÉTANCHÉITÉ	DICHTUNG OR	JUNTA OR		1	
24	R19243001A	MOTORINO AVVIAMENTO COMPLETO	COMPLETE STARTER MOTOR	DÉMARREUR COMPLET	ELEKTRISCHER ANLABMOTOR KOMPLETT	MOTOR DE ARRANQUE COMPLETO		1	

AVVIAMENTO ELETTRICO

AVVIAMENTO
 ELETTRICO

ELECTRIC STARTER

DEMARRAGE
 ELECTRONIQUE

ELEKTROSTARTER
 ANLASSER

PUESTA EN MARCHA
 ELECTRICA

TAVOLA
 DRAWING
 TABLE
 BILD
 TABLA

019

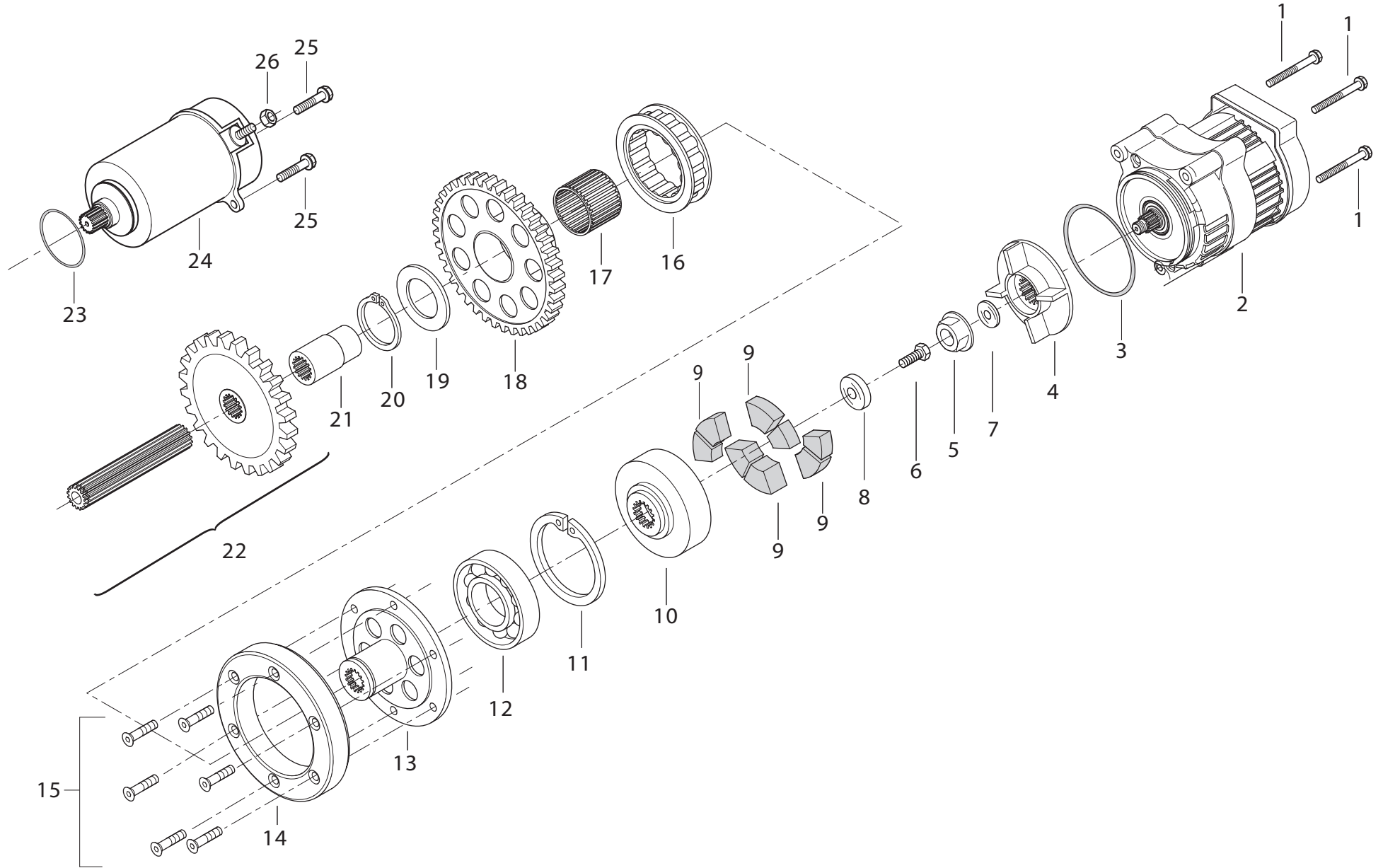

AVVIAMENTO ELETTRICO

 AVVIAMENTO ELETTRICO

 ELECTRIC STARTER

 DEMARRAGE ELECTRONIQUE

 ELEKTROSTARTER ANLASSER

 PUESTA EN MARCHA ELECTRICA

TAVOLA
DRAWING
TABLE
BILD
TABLA

019

POS. NO. N. INDEX POS.	N. CODICE CODE NO. Nr. CODE ATRIKEL Nr. CODICO Nr.	DESCRIZIONE	DESCRIPTION	DESIGNATION	BEZEICHNUNG	DENOMINACION	NOTE NOTES MARKE NOTAS	Q.TA' Q.TY Q.TE M.GE C.AD	
25	R90750692B	VITE	SCREW	VIS	SCHRAUBE	TORNILLO		2	
26	R91350072B	DADO	NUT	ECROU	MUTTER	TUERCA		1	

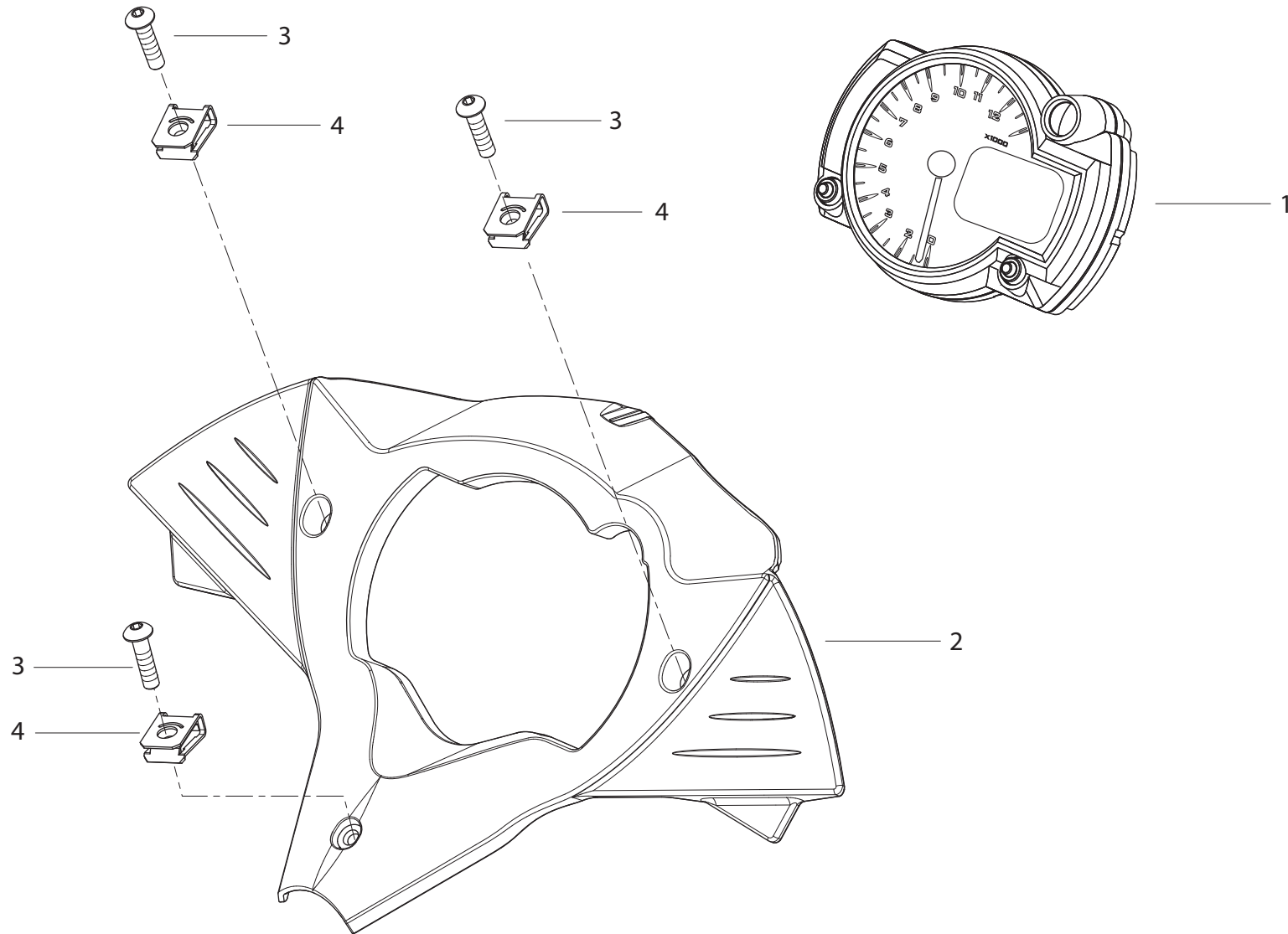

POS. NO. N. INDEX POS.	N. CODICE CODE NO. Nr. CODE ATRIKEL Nr. CODICO Nr.	DESCRIZIONE	DESCRIPTION	DESIGNATION	BEZEICHNUNG	DENOMINACION	NOTE NOTES MARKE NOTAS	Q.TA' Q.TY Q.TE M.GE C.AD	
1	R500080001000	STRUMENTAZIONE	INSTRUMENTATION	INSTRUMENTATION	INSTRUMENTENAUSRÜSTUNG	INSTRUMENTACIÓN		1	
2	R300974250000	COPERTURA SUPPORTO FARO	?	?	?	?		1	
3	R90450438E	VITE	SCREW	VIS	SCHRAUBE	TORNILLO		3	
4	R95050082B	CLIP FISSAGGIO RAPIDO	QUIK FASTENING	FIXATION RAPIDE	SCHNELLEBEFESTIGUNG	FIJACIÓN RÁPIDA		3	

SENSORI

SENSORI

SENSORS

CAPTEURS

SENSOR

SENSORS

TAVOLA
DRAWING
TABLE
BILD
TABLA

021

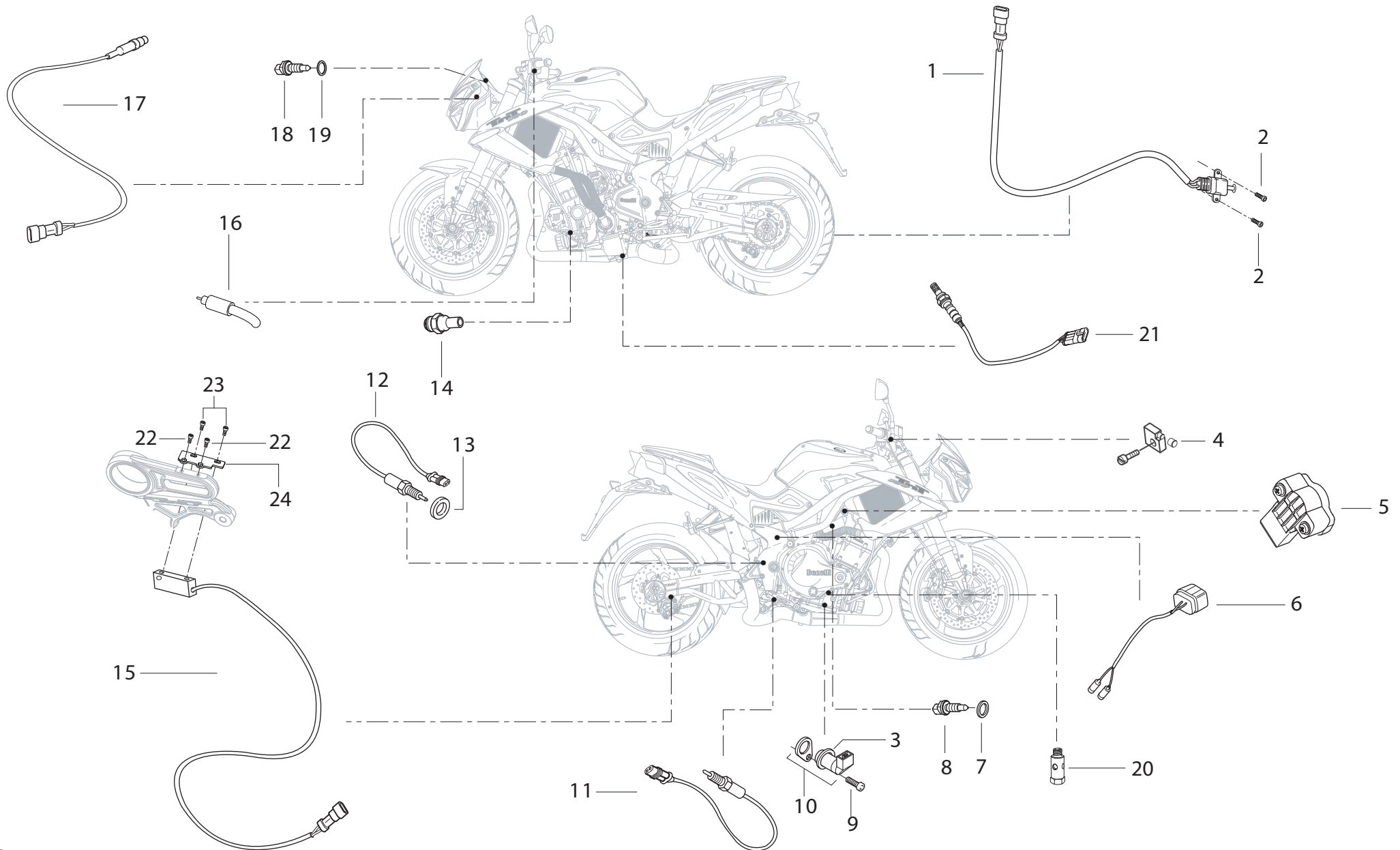

POS. NO. N. INDEX POS.	N. CODICE CODE NO. Nr. CODE ATRIKEL Nr. CODICO Nr.	DESCRIZIONE	DESCRIPTION	DESIGNATION	BEZEICHNUNG	DENOMINACION	NOTE NOTES MARKE NOTAS	Q.TA' Q.TY Q.TE M.GE C.AD	
1	R51840151A0	SENSORE CAVALLETTO LATERALE	SIDE STAND SENSOR	CAPTEUR BÉQUILLE LATERALE	SENSOR SEITENSTÄNDER	SENSOR CABALLETE LATERAL		1	
2	R90750392B	VITE	SCREW	VIS	SCHRAUBE	TORNILLO		2	
3	R300037024000	GUARNIZIONE OR	O-RING	JOINT D'ÉTANCHÉITÉ	DICHTUNG OR	JUNTA OR		1	
4	R300063014000	SENSORE FRENO ANTERIORE	FRONT BRAKE SENSOR	CAPTEUR FREIN AVANT	SENSOR VORDBREMSE	SENSOR FRENO DELANTERO		1	
5	R300037000000	POTENZIOMETRO	POTENTIOMETER	POTENTIOMÈTRE	POTENTIOMETER	POTENCIÓMETRO		1	
6	R300077144000	SENSORE DI CADUTA	SENSOR	CAPTEUR	SENSOR	SENSOR		1	
7	R11543441A	RONDELLA DI TENUTA	STOP WASHER	RONDELLE D' ETANCHÉITÉ	DICHTUNGSRING	ARANDELA DE RETÉN		1	
8	R18243131A	SENSORE TEMPERATURA ACQUA	WATER TEMPERATURE SENSOR	CAPTEUR TEMPÉRATURE EAU	WASSEITEMPERATURSENSOR	SENSOR TEMPERATURA AGUA		1	
9	R90750482B	VITE	SCREW	VIS	SCHRAUBE	TORNILLO		1	
10	R18243141A	SENSORE DI FASE	PHASE SENSOR	CAPTEUR DE PHASE	PHASENFÜHLER	SENSOR DE FASE		1	
11	R180277113000	HYDROSTOP POSTERIORE	REAR HYDROSTOP	HYDROSTOP ARRIÈRE	HINTERER HYDROSTOPP	HYDROSTOP TRASERO		1	
12	R18243271A	INTERRUTTORE FOLLE	NEUTRAL SWITCH	INTERRUPTEUR DU NEUTRE	LEERLAUFSCHALTER	INTERRUPTOR LIBRE		1	
13	R11043701A	RONDELLA DI TENUTA	STOP WASHER	RONDELLE D' ETANCHÉITÉ	DICHTUNGSRING	ARANDELA DE RETÉN		1	
14	R18243081A	SENSORE PRESSIONE	PRESSURE SENSOR	CAPTEUR PRESSION	DRUCKSENSOR	SENSOR PRESIÓN		1	
15	R300081101000	SENSORE VELOCITA'	SPEED SENSOR	SPEED SENSOR	SPEED SENSOR	SPEED SENSOR		1	
16	R180177123000	SENSORE FRIZIONE	CLUTCH SENSOR	CAPTEUR EMBRAYAGE	SENSOR KUPPLUNG	SENSOR EMBRAGUE		1	
17	R180177132000	SONDA TEMPERATURA	TEMPERATURE SENSOR	SONDE TEMPÉRATURE	TEMPERATURSONDE	SONDA TEMPERATURA		1	
18	R300077145000	SENSORE TEMPERATURA ARIA	AIR TEMPERATURE SENSOR	CAPTEUR TEMPÉRATURE AIR	LUFTEMPERATURSENSOR	SENSOR TEMPERATURA AIRE		1	
19	R91350092B	DADO	NUT	ECROU	MUTTER	TUERCA		1	
20	R11523371A	VALVOLA SOVRAPPRESSIONE OLIO	OIL OVER PRESURE VALVE	SOUPAPE SURPRESSION HUILE	ÜBERDRUCK ÖLVENTIL	VÁLVULA SUPERPRESIÓN ACEITE		1	
21	R310077154000	SONDA LAMBDA	LAMBDA SENSOR	LAMBDA SENSOR	LAMBDA SENSOR	LAMBDA SENSOR		1	
22	R90250188E	VITE	SCREW	VIS	SCHRAUBE	TORNILLO		2	
23	R90250078E	VITE	SCREW	VIS	SCHRAUBE	TORNILLO		2	
24	R300057157000	PIASTRINO SENSORE VELOCITÀ	SPEED SENSOR PLATE	PLAQUETTE SPEED SENSOR	SPEED SENSOR PLÄTTCHEN	LÁMINA SPEED SENSOR		1	

POS. NO. INDEX POS.	N. CODICE CODE NO. Nr. CODE ATRIKEL Nr. CODICO Nr.	DESCRIZIONE	DESCRIPTION	DESIGNATION	BEZEICHNUNG	DENOMINACION	NOTE NOTES NOTES MARKS NOTAS	Q.TA' Q.TY Q.TE M.GE C.AD	
1	R51840151A0	SENSORE CAVALLETTO LATERALE	SIDE STAND SENSOR	CAPTEUR BÉQUILLE LATERALE	SENSOR SEITENSTÄNDER	SENSOR CABALLETE LATERAL		1	
2	R90750392B	VITE	SCREW	VIS	SCHRAUBE	TORNILLO		2	
3	R300037024000	GUARNIZIONE OR	O-RING	JOINT D'ÉTANCHÉITÉ	DICHTUNG OR	JUNTA OR		1	
4	R300063014000	SENSORE FRENO ANTERIORE	FRONT BRAKE SENSOR	CAPTEUR FREIN AVANT	SENSOR VORDBREMSE	SENSOR FRENO DELANTERO		1	
5	R300037000000	POTENZIOMETRO	POTENTIOMETER	POTENTIOMÈTRE	POTENTIOMETER	POTENCIÓMETRO		1	
6	R300077144000	SENSORE DI CADUTA	SENSOR	CAPTEUR	SENSOR	SENSOR		1	
7	R11543441A	RONDELLA DI TENUTA	STOP WASHER	RONDELLE D' ETANCHÉITÉ	DICHTUNGSRING	ARANDELA DE RETÉN		1	
8	R18243131A	SENSORE TEMPERATURA ACQUA	WATER TEMPERATURE SENSOR	CAPTEUR TEMPÉRATURE EAU	WASSEITEMPERATURSENSOR	SENSOR TEMPERATURA AGUA		1	
9	R90750482B	VITE	SCREW	VIS	SCHRAUBE	TORNILLO		1	
10	R18243141A	SENSORE DI FASE	PHASE SENSOR	CAPTEUR DE PHASE	PHASENFÜHLER	SENSOR DE FASE		1	
11	R180277113000	HYDROSTOP POSTERIORE	REAR HYDROSTOP	HYDROSTOP ARRIÈRE	HINTERER HYDROSTOPP	HYDROSTOP TRASERO		1	
12	R18243271A	INTERRUTTORE FOLLE	NEUTRAL SWITCH	INTERRUPTEUR DU NEUTRE	LEERLAUFSCHALTER	INTERRUPTOR LIBRE		1	
13	R11043701A	RONDELLA DI TENUTA	STOP WASHER	RONDELLE D' ETANCHÉITÉ	DICHTUNGSRING	ARANDELA DE RETÉN		1	
14	R18243081A	SENSORE PRESSIONE	PRESSURE SENSOR	CAPTEUR PRESSION	DRUCKSENSOR	SENSOR PRESIÓN		1	
15	R300081101000	SENSORE VELOCITA'	SPEED SENSOR	SPEED SENSOR	SPEED SENSOR	SPEED SENSOR		1	
16	R180177123000	SENSORE FRIZIONE	CLUTCH SENSOR	CAPTEUR EMBRAYAGE	SENSOR KUPPLUNG	SENSOR EMBRAGUE		1	
17	R180177132000	SONDA TEMPERATURA	TEMPERATURE SENSOR	SONDE TEMPÉRATURE	TEMPERATURSONDE	SONDA TEMPERATURA		1	
18	R300077145000	SENSORE TEMPERATURA ARIA	AIR TEMPERATURE SENSOR	CAPTEUR TEMPÉRATURE AIR	LUFTEMPERATURSENSOR	SENSOR TEMPERATURA AIRE		1	
19	R91350092B	DADO	NUT	ECROU	MUTTER	TUERCA		1	
20	R11523371A	VALVOLA SOVRAPPRESSIONE OLIO	OIL OVER PRESURE VALVE	SOUPAPE SURPRESSION HUILE	ÜBERDRUCK ÖLVENTIL	VÁLVULA SUPERPRESIÓN ACEITE		1	
21	R310077154000	SONDA LAMBDA	LAMBDA SENSOR	LAMBDA SENSOR	LAMBDA SENSOR	LAMBDA SENSOR		1	
22	R90250188E	VITE	SCREW	VIS	SCHRAUBE	TORNILLO		2	
23	R90250078E	VITE	SCREW	VIS	SCHRAUBE	TORNILLO		2	
24	R300057157000	PIASTRINO SENSORE VELOCITÀ	SPEED SENSOR PLATE	PLAQUETTE SPEED SENSOR	SPEED SENSOR PLÄTTCHEN	LÁMINA SPEED SENSOR		1	

FANALI

 **FANALI**

 **HEAD-LIGHTS**

 **PHARES**

 **SCHWEINWERFERS**

 **FAROS**

TAVOLA
 DRAWING
 TABLE
 BILD
 TABLA

022

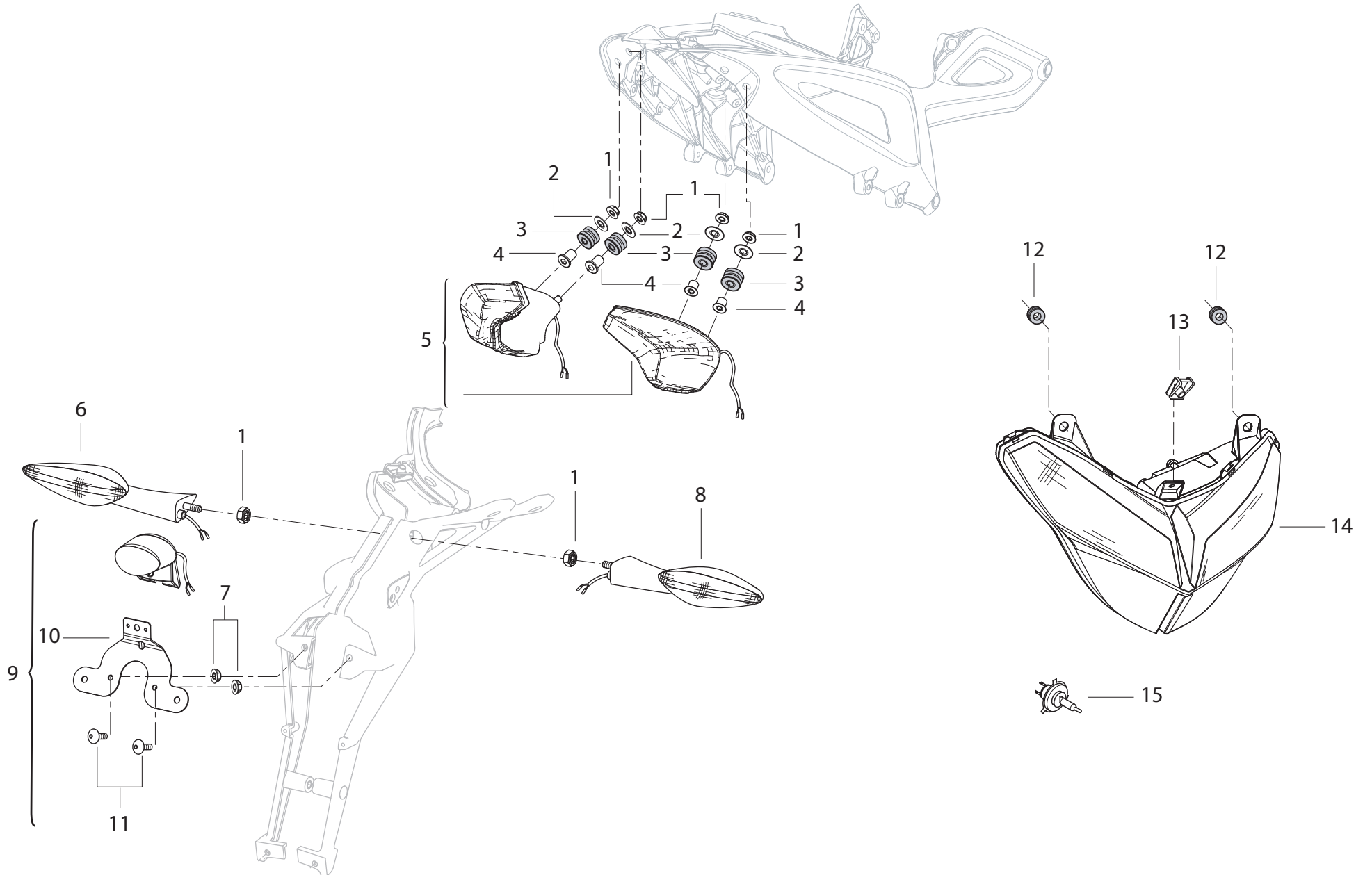

POS. NO. INDEX POS.	N. CODICE CODE NO. Nr. CODE ATRIKEL Nr. CODICO Nr.	DESCRIZIONE	DESCRIPTION	DESIGNATION	BEZEICHNUNG	DENOMINACION	NOTE NOTES NOTES MARKE NOTAS	Q.TA' Q.TY Q.TE M.GE C.AD	
1	R91350072B	DADO	NUT	ECROU	MUTTER	TUERCA		6	
2	R92051002B	RONDELLA	WASHER	RONDELLE	UNTERLEGSCHIEBE	ARANDELA		4	
3	R300079190000	ANTIVIBRANTE	VIBRATION DAMPER	ANTIVIBRATION	SCHWINGUNGSDÄMPFER	ANTI-VIBRACIÓN		4	
4	R300079191000	BOCCOLA	BUSH	DOUILLE	BUCHSE	CASQUILLO		4	
5	R300078118000	FARO POSTERIORE COMPLETO	COMPLETE REAR LIGHT	FEU ARRIÈRE COMPLET	RÜCKLICHT KOMPLETT	FARO TRASERO COMPLETO		1	
6	R180278003000	INDICATORE DIREZIONE POST.SX	REAR L.H.TURN INDICATOR	CLIGNOTANT ARRIÈRE GAUCHE	FAHRTRICHTUNGSANZEIGE HINTERERS LINK	INDICADOR DE DIRECCIÓN TRASERO IZQ.		1	
7	R91350062B	DADO	NUT	ECROU	MUTTER	TUERCA		2	
8	R180278004000	INDICATORE DIREZIONE POST.DX	REAR R.H.TURN INDICATOR	CLIGNOTANT ARRIÈRE DROIT	FAHRTRICHTUNGSANZEIGE HINTERERS RECHT	INDICADOR DE DIRECCIÓN TRASERO DER.		1	
9	R300078123001	LUCE TARGA	NUMBER PLATE LIGHT	FEU PLAQUE MINERALOGIQUE	KENNZEICHENBELEUCHTUNG	LUZ MATRÍCULA		1	
10	R300057158000	PIASTRINO	PLATE	PLAQUETTE	PLÄTTCHEN	LÁMINA		1	
11	R90750182B	VITE	SCREW	VIS	SCHRAUBE	TORNILLO		2	
12	R100279118000	GOMMINO ANTIVIBRANTE	VIBRATION DAMPER PAD	JOINT EN CAOUTCHOUC ANTI-VIBRATION	SCHWINGUNGSDÄMPFERGUMMI	JUNTA DE GOMA ANTI-VIBRACIÓN		2	
13	R95050012A	CLIP FISSAGGIO RAPIDO	QUIK FASTENING	FIXATION RAPIDE	SCHNELLEBEFESTIGUNG	FIJACIÓN RÁPIDA		1	
14	R300078000000	FANALE ANTERIORE	FRONT HEAD LIGHT	PHARE AVANT	VORDESCHINWERFER	FARO DELANTERO		1	
15	R180178116000	LAMPADA	BULB	LAMPE	BIRNE	LÁMPARA		1	

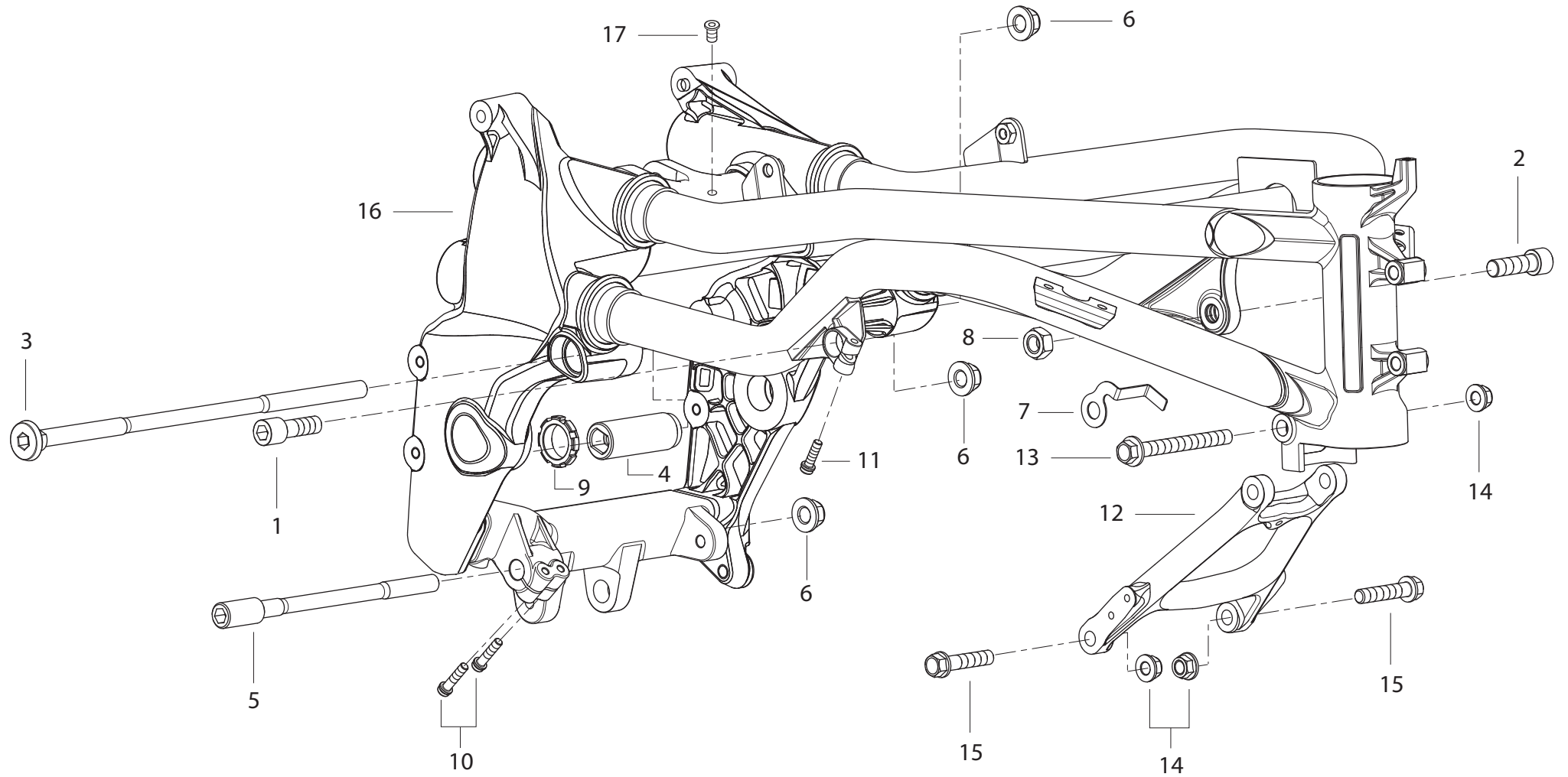

POS. NO. N. INDEX POS.	N. CODICE CODE NO. Nr. CODE ATRIKEL Nr. CODICO Nr.	DESCRIZIONE	DESCRIPTION	DESIGNATION	BEZEICHNUNG	DENOMINACION	NOTE NOTES MARKE NOTAS	Q.TA' Q.TY Q.TE M.GE C.AD	
1	R21214681A	VITE	SCREW	VIS	SCHRAUBE	TORNILLO		1	
2	R21214671A	VITE	SCREW	VIS	SCHRAUBE	TORNILLO		1	
3	R21214581A	VITE	SCREW	VIS	SCHRAUBE	TORNILLO		1	
4	R21214611A	REGISTRO	ADJUSTER	RÉGLAGE	REGISTER	REGISTRO		1	
5	R300052004000	VITE SPECIALE	SPECIAL SCREW	VIS SPÉCIALE	SPEZIALSCHRAUBE	TORNILLO ESPECIAL		1	
6	R91350102B	DADO	NUT	ECROU	MUTTER	TUERCA		3	
7	R180157137000	PIASTRA	PLATE	PLAQUE	PLATTE	SOPORTE		1	
8	R90752212B	DADO	NUT	ECROU	MUTTER	TUERCA		1	
9	R21215411A	GHIERA	RING NUT	EMBOUT	NUTMUTTER	TUERCA		1	
10	R90750522B	VITE	SCREW	VIS	SCHRAUBE	TORNILLO		2	
11	R90750512B	VITE	SCREW	VIS	SCHRAUBE	TORNILLO		1	
12	R300054008000	SUPPORTO MOTORE	ENGINE HOLDER	SUPPORT MOTEUR	HALTERUNG MOTOR	SOPORTE MOTOR		1	
13	R21214701A	VITE	SCREW	VIS	SCHRAUBE	TORNILLO		1	
14	R91350092B	DADO	NUT	ECROU	MUTTER	TUERCA		3	
15	R90753062B	VITE	SCREW	VIS	SCHRAUBE	TORNILLO		2	
16	R3000500000CM	TELAIO NERO	BLACK FRAME	CADRE NOIR	RAHMEN SCHWARZ	CHASIS NEGRO		1	
16	R3000500000C6	TELAIO GRIGIO	GREY FRAME	CADRE GRIS	RAHMEN GRAU	CHASIS GRIS		1	
17	R90752928E	RIVETTO SVASATO	COUNTERSUNK RIVET	RIVET FRAISÉ	LINSENSENKNIET	REMACHE ABOCINADO		1	

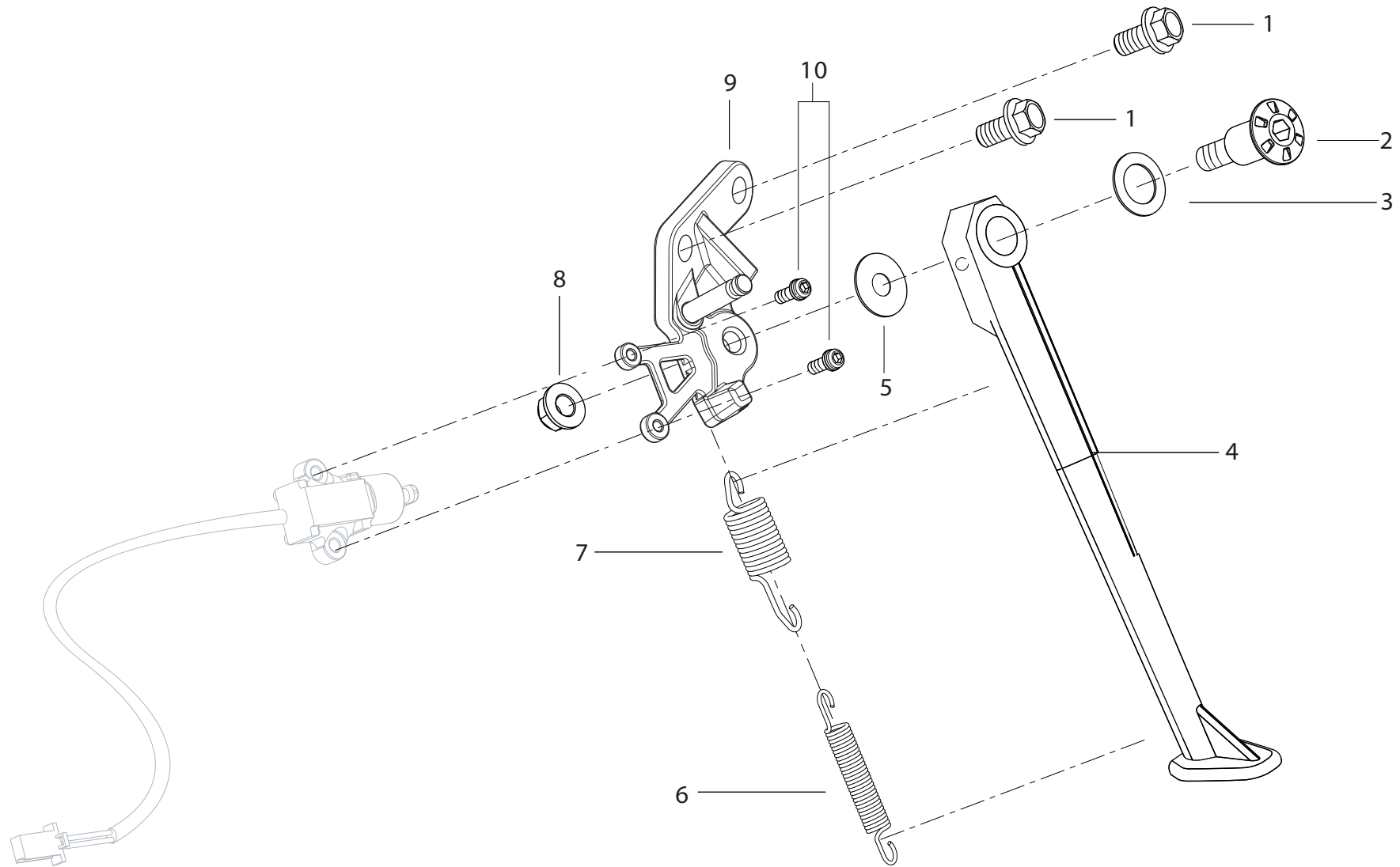

POS. NO. N. INDEX POS.	N. CODICE CODE NO. Nr. CODE ATRIKEL Nr. CODICO Nr.	DESCRIZIONE	DESCRIPTION	DESIGNATION	BEZEICHNUNG	DENOMINACION	NOTE NOTES MARKE NOTAS	Q.TA' Q.TY Q.TE M.GE C.AD	
1	R90751522B	VITE	SCREW	VIS	SCHRAUBE	TORNILLO		2	
2	R21215361A	VITE SPECIALE	SPECIAL SCREW	VIS SPÉCIALE	SPEZIALSCHRAUBE	TORNILLO ESPECIAL		1	
3	R21215341A	RONDELLA	WASHER	RONDELLE	UNTERLEGSCHIEBE	ARANDELA		1	
4	R1801550020W3	CAVALLETTO LATERALE	SIDE STAND	BÉQUILLE LATERALE	SEITENSTÄNDER	CABALLETE LATERAL		1	
5	R90752141A	RONDELLA	WASHER	RONDELLE	UNTERLEGSCHIEBE	ARANDELA		1	
6	R300055104000	MOLLA INTERNA	INNER SPRING	RESSORT INTERNE	INNERE FEDER	MUELLE INTERIOR		1	
7	R300055105000	MOLLA ESTERNA	OUTER SPRING	RESSORT EXTERNE	ÄÜßERE FEDER	MUELLE EXTERIOR		1	
8	R91350092B	DADO	NUT	ECROU	MUTTER	TUERCA		1	
9	R30005510200X	PIASTRA	PLATE	PLAQUE	PLATTE	SOPORTE		1	
10	R90750392B	VITE	SCREW	VIS	SCHRAUBE	TORNILLO		2	

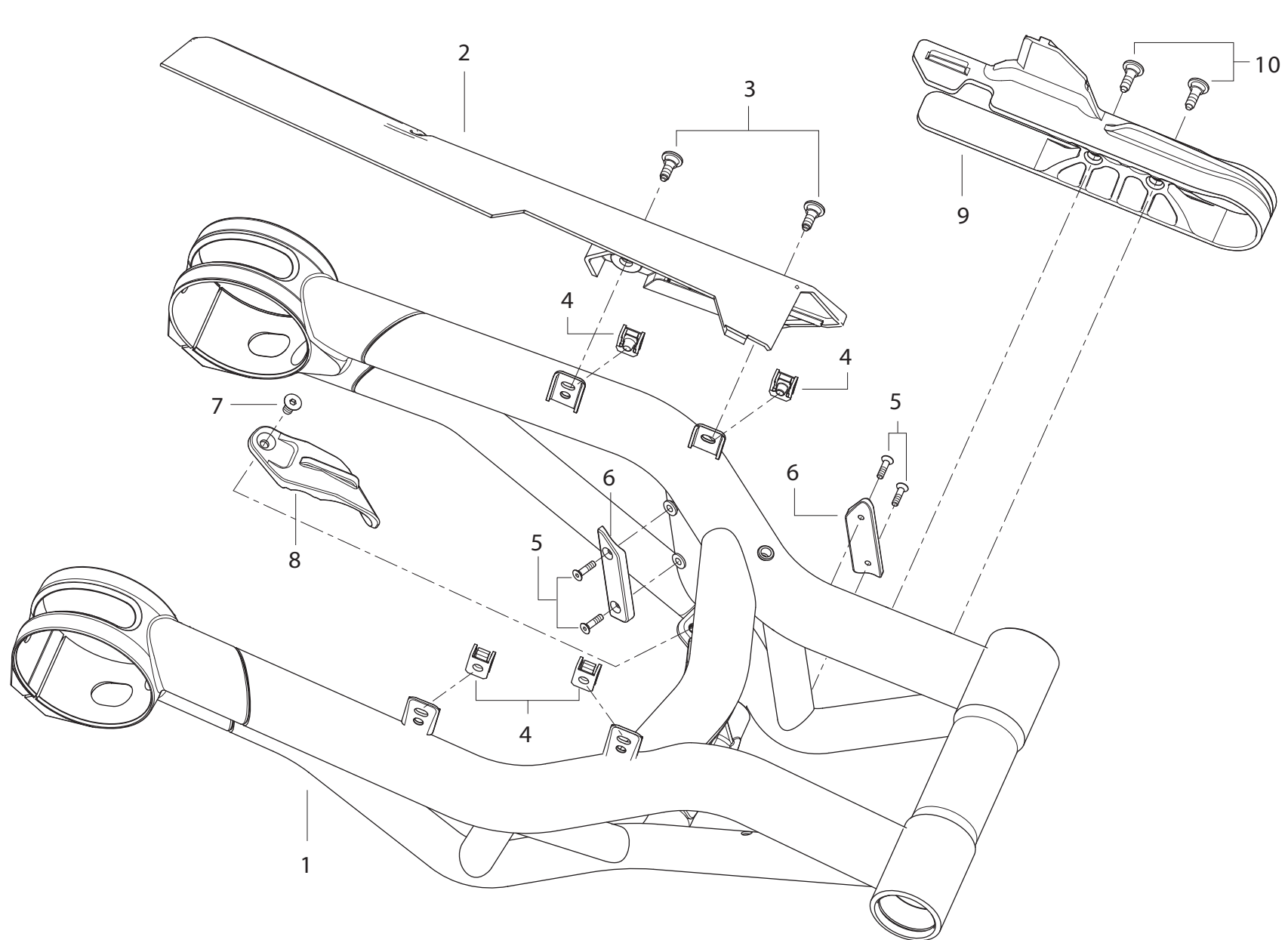

POS. NO. N. INDEX POS.	N. CODICE CODE NO. Nr. CODE ATRIKEL Nr. CODICO Nr.	DESCRIZIONE	DESCRIPTION	DESIGNATION	BEZEICHNUNG	DENOMINACION	NOTE NOTES MARKE NOTAS	Q.TA' Q.TY Q.TE M.GE C.AD	
1	R3000700000CM	FORCELLONE NERO	BLACK SWINGARM	FOURCHE NOIR	SCHWINGE SCHWARZ	BASCULANTE NEGRO		1	
1	R3000700000C6	FORCELLONE GRIGIO	GREY SWINGARM	FOURCHE GRIS	SCHWINGE GRAU	BASCULANTE GRIS		1	
2	R3000742060CA	COPRI CATENA	CHAIN CARTER	CARTER CHAÎNE	KETTENABDECKUNG	CUBRE-CADENA		1	
3	R90752268E	VITE	SCREW	VIS	SCHRAUBE	TORNILLO		2	
4	R95050012A	CLIP FISSAGGIO RAPIDO	QUIK FASTENING	FIXATION RAPIDE	SCHNELLBEFESTIGUNG	FIJACIÓN RÁPIDA		4	
5	R90650222B	VITE	SCREW	VIS	SCHRAUBE	TORNILLO		4	
6	R300027027000	PATTINO CATENA	CHAIN SLIDING SHOE	PATIN CHAÎNE	KETTENGLEITSCHUN	PATÍN CADENA		2	
7	R90650482B	VITE	SCREW	VIS	SCHRAUBE	TORNILLO		1	
8	R300027028000	PATTINO CATENA INFERIORE	LOWER CHAIN SLIDING SHOE	PATIN CHAÎNE INFÉRIEURE	UNTERER KETTENGLEITSCHUN	PATÍN CADENA INFERIOR		1	
9	R300070160000	PATTINO CATENA SUPERIORE	UPPER CHAIN SLIDING SHOE	PATIN CHAÎNE SUPÉRIEURE	OBERER KETTENGLEITSCHUN	PATÍN CADENA SUPERIOR		1	
10	R90750708E	VITE	SCREW	VIS	SCHRAUBE	TORNILLO		2	

ASSIEME FORCELLONE



ASSIEME FORCELLONE



SWING ARM ASSEMBLY



ENSEMBLE FOURCHE



GABEL KOMPLETT



GRUPO BASCULANTE

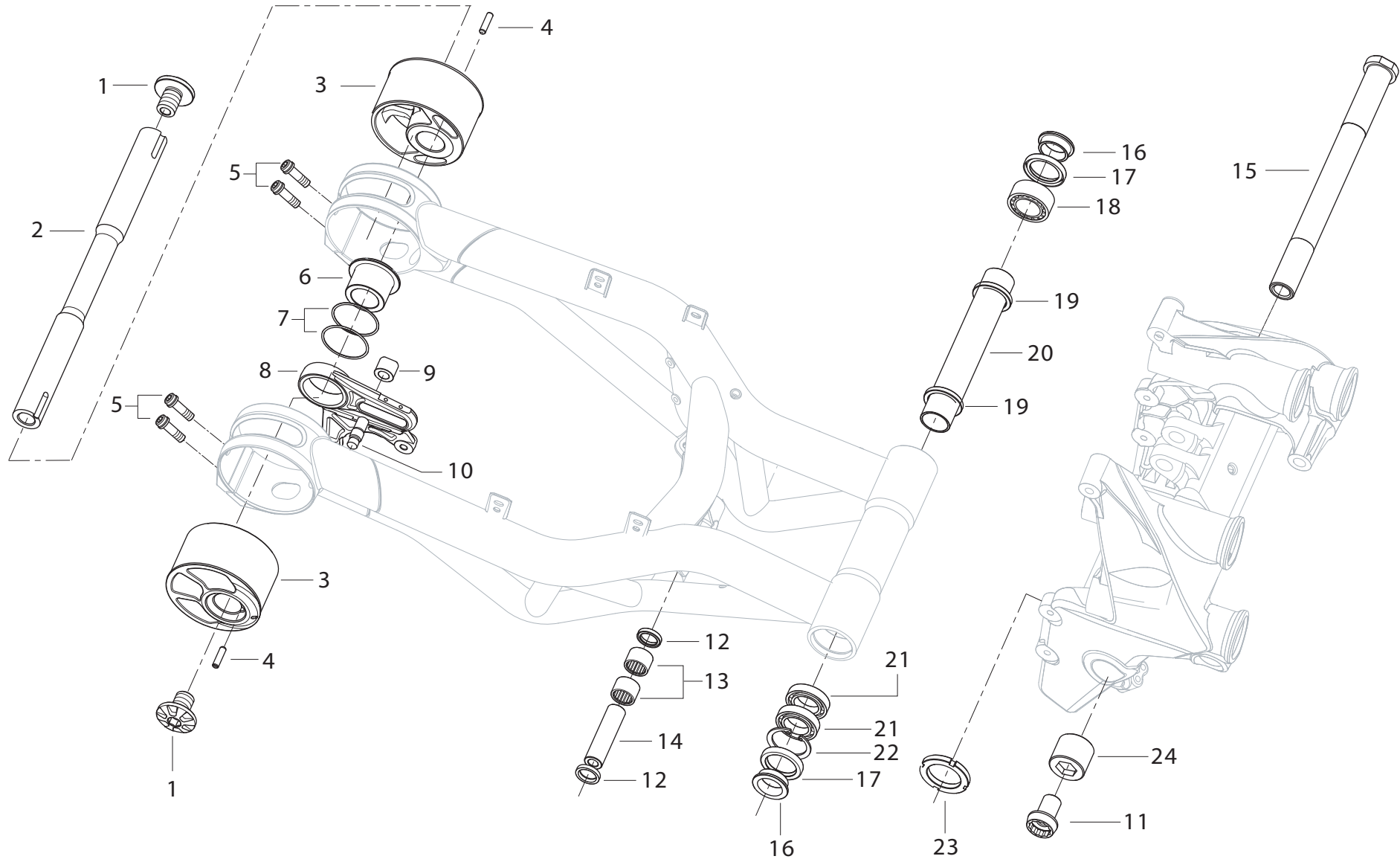



ASSIEME FORCELLONE



SWING ARM ASSEMBLY



ENSEMBLE FOURCHE



GABEL KOMPLETT



GRUPO BASCULANTE

POS. NO. N. INDEX POS.	N. CODICE CODE NO. Nr. CODE ATRIKEL Nr. CODICO Nr.	DESCRIZIONE	DESCRIPTION	DESIGNATION	BEZEICHNUNG	DENOMINACION	NOTE NOTES MARKE NOTAS	Q.TA' Q.TY Q.TE M.GE C.AD	
1	R300072119000	VITE SPECIALE	SPECIAL SCREW	VIS SPÉCIALE	SPEZIALSCHRAUBE	TORNILLO ESPECIAL		2	
2	R300072108000	PERNO	PIN	PIVOT	ZAPFEN	PERNO		1	
3	R300000096000	KIT ECCENTRICO	ECCENTRIC KIT	KIT EXCENTRIQUE	KIT EXZENTERNABE	KIT EXCÉNTRICO		1	
4	R93850060C	SPINA	PIN	GOUPILLE	STIFT	PASADOR		2	
5	R90751452B	VITE	SCREW	VIS	SCHRAUBE	TORNILLO		4	
6	R300063123000	BOCCOLA	BUSH	DOUILLE	BUCHSE	CASQUILLO		1	
7	R300063126000	GUARNIZIONE OR	O-RING	JOINT D'ÉTANCHÉITÉ	DICHTUNG OR	JUNTA OR		2	
8	R300063116000	PIASTRA PORTAPINZA	CALIPER HOLDER PLATE	PLAQUE PORTE-PINCE	BREMSZANGENPLATTE	LÁMINA PORTA-PINZA		1	
9	R300063125000	BOCCOLA	BUSH	DOUILLE	BUCHSE	CASQUILLO		1	
10	R300070139000	PERNO	PIN	PIVOT	ZAPFEN	PERNO		1	
11	R21214511A	VITE SPECIALE	SPECIAL SCREW	VIS SPÉCIALE	SPEZIALSCHRAUBE	TORNILLO ESPECIAL		1	
12	R21813741A	ANELLO DI TENUTA	SEAL RING	BAGUE D'ÉTANCHÉITÉ	DICHTRING	ANILLO DE RETÉN		2	
13	R21215011A	CUSCINETTO A RULLI	ROLLER BEARING	COUSSINET A ROULEAUX	ROLLENLAGER	COJINETE RODILLOS		2	
14	R21214761A	DISTANZIALE	SPACER	ENTRETOISE	DISTANZSTÜCK	DISTANCIAL		1	
15	R180270001000	PERNO	PIN	PIVOT	ZAPFEN	PERNO		1	
16	R300072122000	BOCCOLA	BUSH	DOUILLE	BUCHSE	CASQUILLO		2	
17	R300002034000	ANELLO DI TENUTA	SEAL RING	BAGUE D'ÉTANCHÉITÉ	DICHTRING	ANILLO DE RETÉN		2	
18	R300002033000	CUSCINETTO A RULLI	ROLLER BEARING	COUSSINET A ROULEAUX	ROLLENLAGER	COJINETE RODILLOS		1	
19	R300070138000	ANELLO DI CENTRAGGIO	CENTERING RING	BAGUE DE CENTRAGE	ZENTRIERRING	ANILLO DE CENTRADO		2	
20	R300070137000	DISTANZIALE INTERNO	INNER SPACER	ENTRETOISE INTERNE	INNERES DISTANZSTÜCK	DISTANCIADOR INTERIOR		1	
21	R300002032000	CUSCINETTO	BEARING	ROULEMENT	LAGER	COJINETE		2	
22	R92550420D	ANELLO SEEGER	CIRCLIP	CIRCLIP	SEEGERRING	ANILLO SEEGER		1	
23	R21214551A	GHIERA	RING NUT	EMBOUT	NUTMUTTER	TUERCA		1	
24	R21214541A	REGISTRO	ADJUSTER	RÉGLAGE	REGISTER	REGISTRO		1	

SOSPENSIONE POSTERIORE

🇮🇹 SOSPENSIONE POSTERIORE

🇬🇧 REAR SUSPENSION

🇫🇷 SUSPENSION ARRIÈRE

🇩🇪 HINTERRADFEDERUNG

🇪🇸 SUSPENSION TRASERA

TAVOLA
 DRAWING
 TABLE
 BILD
 TABLA

027

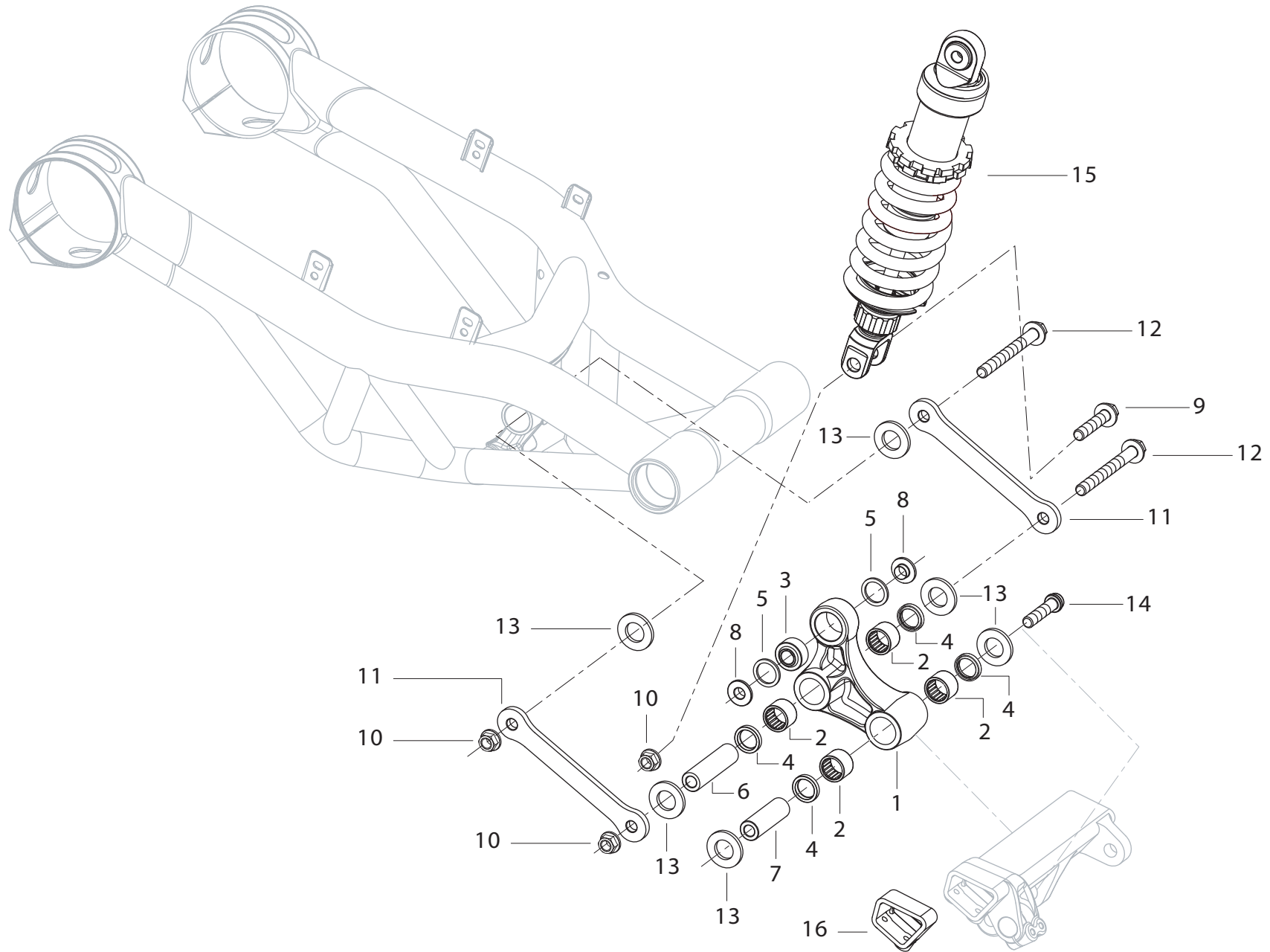

POS. NO. INDEX POS.	N. CODICE CODE NO. Nr. CODE ATRIKEL Nr. CODICO Nr.	DESCRIZIONE	DESCRIPTION	DESIGNATION	BEZEICHNUNG	DENOMINACION	NOTE NOTES NOTES MARKE NOTAS	Q.TA' Q.TY Q.TE M.GE C.AD	
1	R21813561	BILANCIERE	ROCKER	CULBUTEUR	KIPPEBEL	BALANCÍN		1	
2	R21215011A	CUSCINETTO A RULLI	ROLLER BEARING	COUSSINET A ROULEAUX	ROLLENLAGER	COJINETE RODILLOS		4	
3	R21813731A	SNODO	JOINT	JOINT	GELENK	ARTICULACIÓN		1	
4	R21813741A	ANELLO DI TENUTA	SEAL RING	BAGUE D'ÉTANCHÉITÉ	DICHTRING	ANILLO DE RETÉN		4	
5	R31840071A0	GUARNIZIONE OR	O-RING	JOINT D'ÉTANCHÉITÉ	DICHTUNG OR	JUNTA OR		2	
6	R21214761A	DISTANZIALE	SPACER	ENTRETOISE	DISTANZSTÜCK	DISTANCIAL		1	
7	R21214751A	DISTANZIALE	SPACER	ENTRETOISE	DISTANZSTÜCK	DISTANCIAL		1	
8	R21214641A	DISTANZIALE	SPACER	ENTRETOISE	DISTANZSTÜCK	DISTANCIAL		2	
9	R21214771A	VITE	SCREW	VIS	SCHRAUBE	TORNILLO		1	
10	R91350092B	DADO	NUT	ECROU	MUTTER	TUERCA		3	
11	R21313311A	BIELLETTA	CONNECTING ROD	BIELLETTA	PLEUELSTANGE	BIELA		2	
12	R21214701A	VITE	SCREW	VIS	SCHRAUBE	TORNILLO		2	
13	R21813571A	RONDELLA	WASHER	RONDELLE	UNTERLEGSCHIEBE	ARANDELA		6	
14	R21213561A	VITE	SCREW	VIS	SCHRAUBE	TORNILLO		1	
15	R300070100000	AMMORTIZZATORE POSTERIORE	REAR SHOCK ABSORBER	AMORTISSEUR ARRIÈRE	STOßDÄMPFER HINTERE	AMORTIGUADOR TRASERO		1	
16	R21814771A	PATTINO CATENA INFERIORE	LOWER CHAIN SLIDING SHOE	PATIN CHAÎNE INFÉRIEURE	UNTERER KETTENGLEITSCHUH	PATÍN CADENA INFERIOR		1	

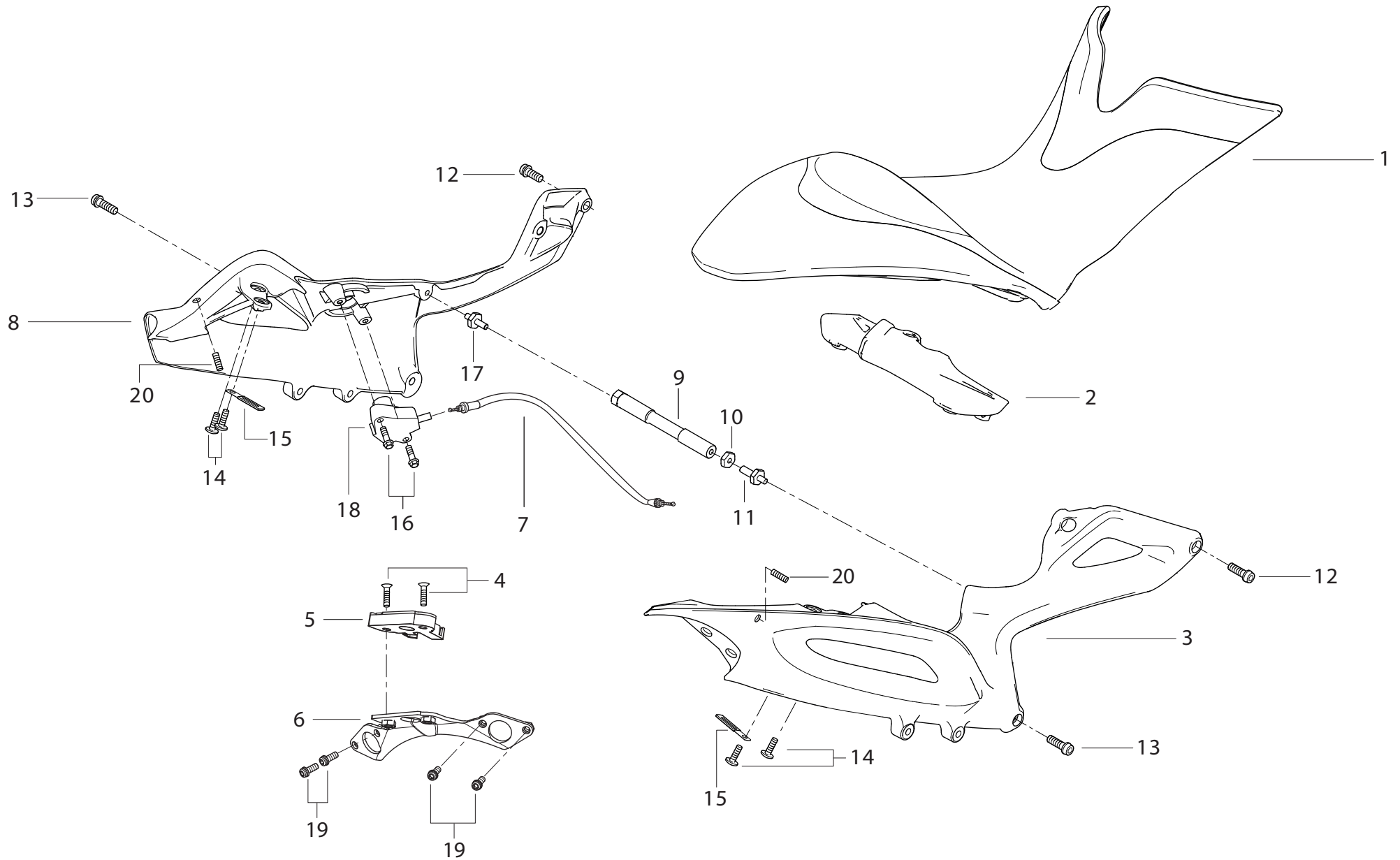

POS. NO. N. INDEX POS.	N. CODICE CODE NO. Nr. CODE ATRIKEL Nr. CODICO Nr.	DESCRIZIONE	DESCRIPTION	DESIGNATION	BEZEICHNUNG	DENOMINACION	NOTE NOTES NOTES MARKE NOTAS	Q.TA' Q.TY Q.TE M.GE C.AD	
1	R300975000000	SELLA	SEAT	SIEGE	SATTEL	SILLÍN		1	
2	R30015000900X	TRAVERSO POSTERIORE NERO	BLACK BACK SPRING	TRAVERSE ARRIÈRE NOIR	HINTERE QUERSTANGE SCHWARZ	TRAVESERO TRASERO NEGRO		1	
3	R30095000800X	TELAJETTO POSTERIORE DX GRIGIO	REAR GREY R.H. FRAME	CADRE ARRIÈRE DROITE GRIS	HINTERER RAHMEN RECHT GRAU	CHASSIS TRASERO DER. GRIS		1	
4	R90650542B	VITE	SCREW	VIS	SCHRAUBE	TORNILLO		2	
5	R180266102000	GANCIO SELLA	SEAT HOOK	CROCHET SELLE	HAKEN SITZ	GANCHO SILLÍN		1	
6	R30095704700X	PIASTRA	PLATE	PLAQUE	PLATTE	SOPORTE		1	
7	R310066126000	CAVO APERTURA SELLA	SEAT CABLE OPENING SEAT	CÂBLE OVERTURE SIEGE	ÖFFNUNGSKABEL SATTEL	CABLE ABERTURA SILLÍN		1	
8	R30095000700X	TELAIO POSTERIORE SX NERO	REAR BLACK L.H. FRAME	CADRE ARRIÈRE GAUCHE NOIR	HINTERER RAHMEN LINKS SCHWARZ	CHASSIS TRASERO IZQ. NERO		1	
9	R300050018000	SUPPORTO SELLA	STUD BOLT HOLDER	SUPPORT GOUJON	HALTERUNG STIFTSCHRAUBE	SOPORTE SILLÍN		1	
10	R90752992B	DADO SPECIALE	SPECIAL NUT	ECROU SPÉCIALE	SPEZIALMUTTER	TUERCA ESPECIAL		1	
11	R300015014000	PRIGIONIERO DX	R.H. STUD BOLT	GOUJON DROITE	STIFTSCHRAUBE RECHTS	TORNILLO SIN FIN DER.		1	
12	R90751432B	VITE	SCREW	VIS	SCHRAUBE	TORNILLO		2	
13	R90751452B	VITE	SCREW	VIS	SCHRAUBE	TORNILLO		2	
14	R90752162B	VITE	SCREW	VIS	SCHRAUBE	TORNILLO		4	
15	R300068104000	FASCETTA IN GOMMA	RUBBER HOSE CLAMP	COLLIER EN CAOUTCHOUC	GUMMISCHELLE	ABRAZADERA EN GOMA		2	
16	R90750672B	VITE	SCREW	VIS	SCHRAUBE	TORNILLO		2	
17	R300015015000	PRIGIONIERO SX	L.H. STUD BOLT	GOUJON GAUCHE	STIFTSCHRAUBE LINKS	TORNILLO SIN FIN IZQ.		1	
18	R300066101000	LEVA SERRATURA SELLA	SEAT LOCK LEVER	LEVIER SERRURE SELLE	HEBEL SATTELSCHLOß	LEVA CERRADURA SILLÍN		1	
19	R90750392B	VITE	SCREW	VIS	SCHRAUBE	TORNILLO		4	
20	R300015015000	GRANO	DOWEL	VIS SANS TÊTE	STIFT	CLAVIJA		2	

SCATOLA BATTERIA

 SCATOLA BATTERIA

 BATTERY BOX

 BOÎTE BATTERIE

 BATTERIEGEHÄUSE

 CAJA BATERÍA

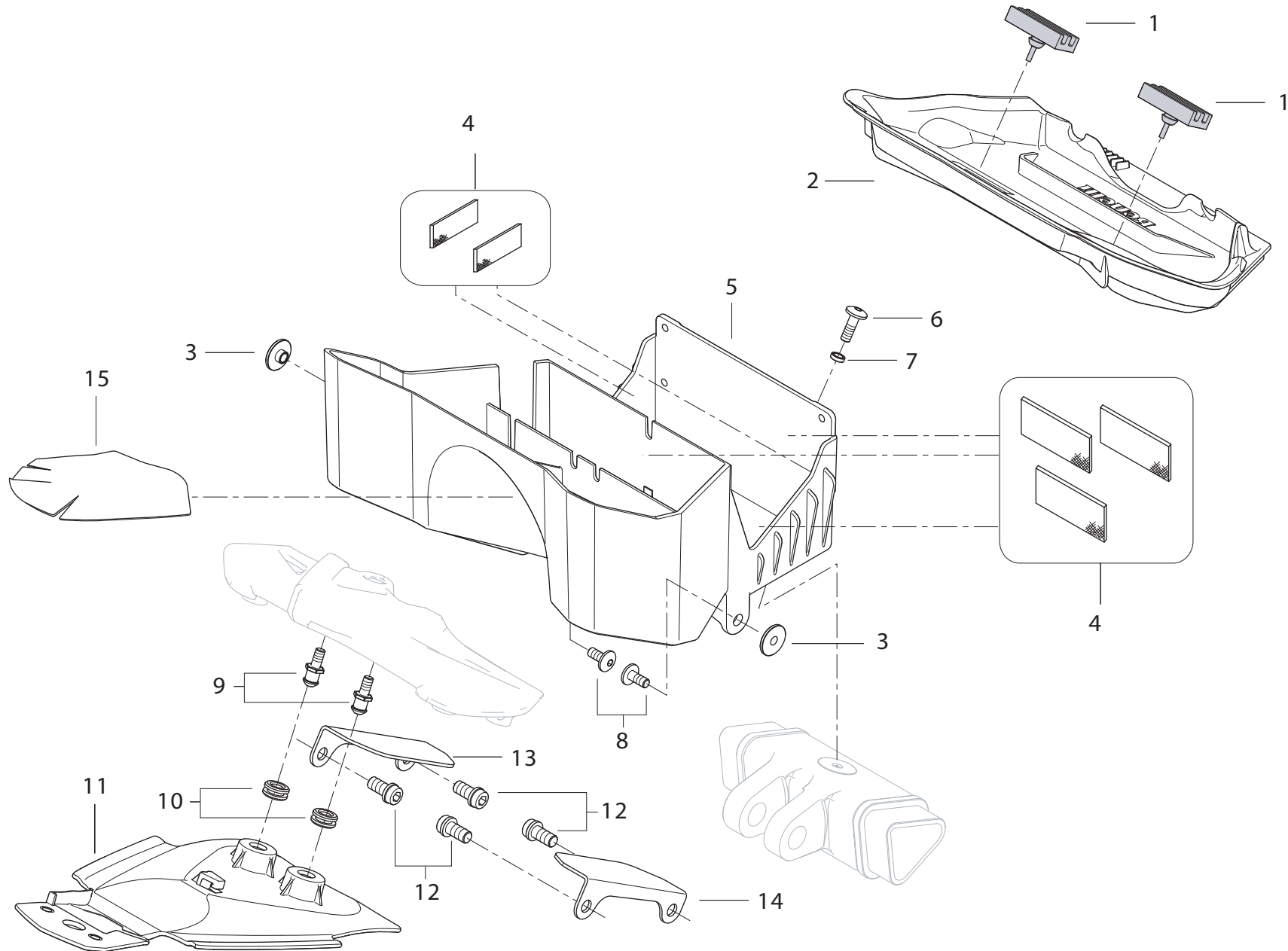

POS. NO. INDEX POS.	N. CODICE CODE NO. Nr. CODE ATRIKEL Nr. CODICO Nr.	DESCRIZIONE	DESCRIPTION	DESIGNATION	BEZEICHNUNG	DENOMINACION	NOTE NOTES MARKE NOTAS	Q.TA' Q.TY Q.TE M.GE C.AD	
1	R300079189000	TAMPONE	PAD	TAMPON	STOPFEN	APOYO		2	
2	R310074211000	COPERCHIO	COVER	COUVERCLE	DECKEL	TAPA		1	
3	R300079188000	BOCCOLA	BUSH	DOUILLE	BUCHSE	CASQUILLO		2	
4	R51840081AZ	ANTIVIBRANTE	VIBRATION DAMPER	ANTIVIBRATION	SCHWINGUNGSDÄMPFER	ANTI-VIBRACIÓN		5	
5	R300074210001	SCATOLA SUPPORTO BATTERIA	BATTERY BOX MOUNT	SUPPORT BOÎTE BATTERIE	BATTERIEHALTERUNG	SOPORTE CAJA BATERÍA		1	
6	R90752162B	VITE	SCREW	VIS	SCHRAUBE	TORNILLO		1	
7	R90752972B	BOCCOLA	BUSH	DOUILLE	BUCHSE	CASQUILLO		1	
8	R90752032B	VITE	SCREW	VIS	SCHRAUBE	TORNILLO		2	
9	R300052003000	VITE SPECIALE	SPECIAL SCREW	VIS SPÉCIALE	SPEZIALSCHRAUBE	TORNILLO ESPECIAL		2	
10	R100279118000	GOMMINO ANTIVIBRANTE	VIBRATION DAMPER PAD	JOINT EN CAOUTCHOUC ANTI-VIBRATION	SCHWINGUNGSDÄMPFERGUMMI	JUNTA DE GOMA ANTI-VIBRACIÓN		2	
11	R310074001000	COPERCHIO PARACALORE	HEAT GUARD COVER	COUVERCLE PARE-CHALEUR	DECKEL WÄRMESCHUTZ	TAPA PROTECCIÓN CALOR		1	
12	R90751422B	VITE	SCREW	VIS	SCHRAUBE	TORNILLO		4	
13	R300057005000	STAFFA SX	L.H. BRACKET	BRIDE GAUCHE	LINKER BÜGEL	SOPORTE IZQ.		1	
14	R300057006000	STAFFA DX	R.H. BRACKET	BRIDE DROITE	RECHTER BÜGEL	SOPORTE DER.		1	
15	R300091004000	TERMORIFLETTENTE	REFLECTING GLAZING	RÉFLÉCHISSANT	WÄRMEREFLEKTIERENDE	REFLECTANTE DEL CALOR		1	

PORTATARGA

PORTATARGA

NUMBER PLATE
HOLDER

PORTE-PLAQUE

NUMMERSCHILDTAFEL

PORTA-MATRÍCULA

TAVOLA
DRAWING
TABLE
BILD
TABLA

030

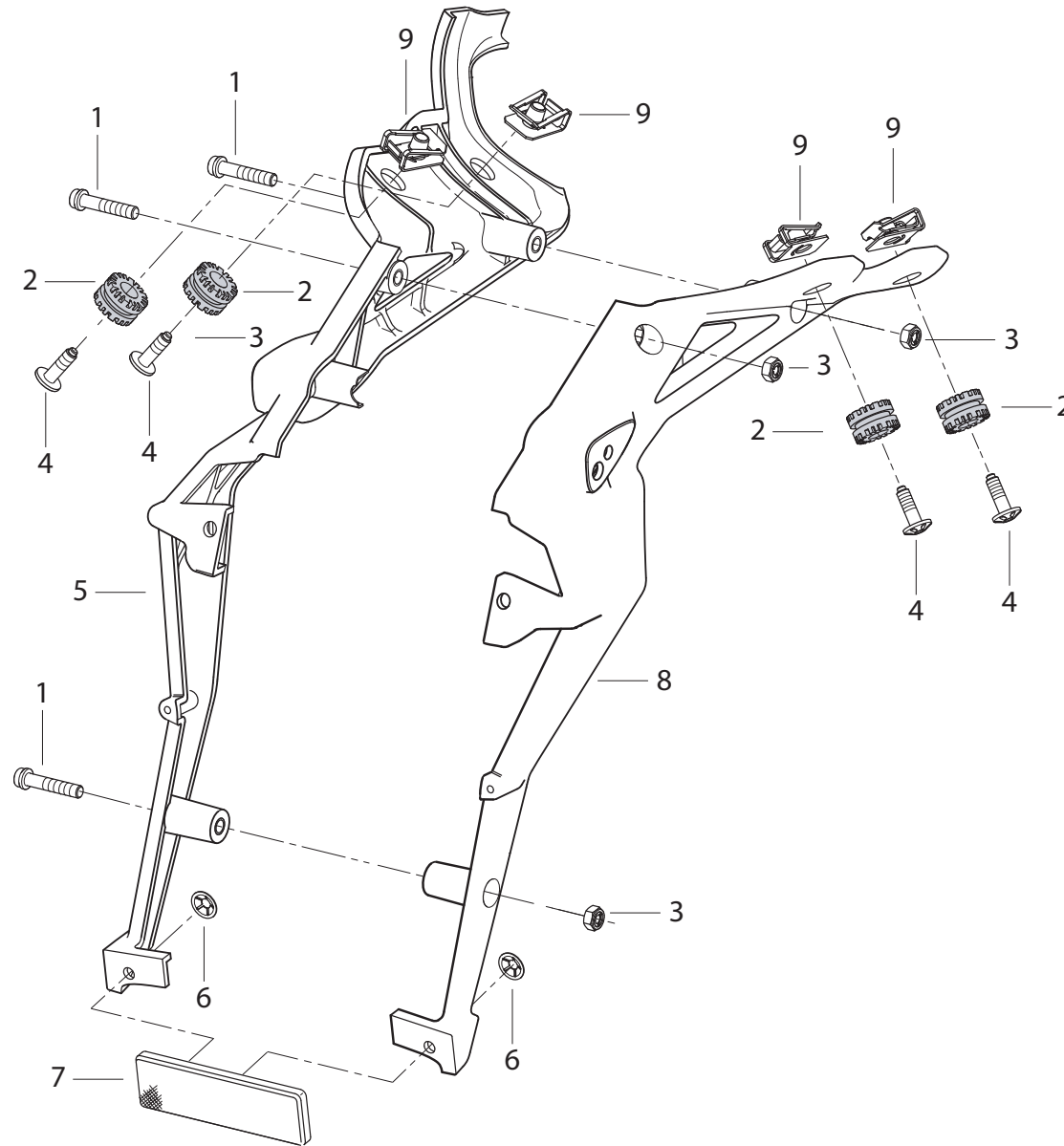

POS. NO. N. INDEX POS.	N. CODICE CODE NO. Nr. CODE ATRIKEL Nr. CODICO Nr.	DESCRIZIONE	DESCRIPTION	DESIGNATION	BEZEICHNUNG	DENOMINACION	NOTE NOTES MARKE NOTAS	Q.TA' Q.TY Q.TE M.GE C.AD	
1	R90750522B	VITE	SCREW	VIS	SCHRAUBE	TORNILLO		4	
2	R180479181000	GOMMINO	RUBBER PAD	JOINT EN CAOUTCHOUC	GUMMISTÜCK	JUNTA DE GOMA		4	
3	R91750032B	DADO	NUT	ECROU	MUTTER	TUERCA		3	
4	R90750198E	VITE	SCREW	VIS	SCHRAUBE	TORNILLO		4	
5	R300074215000	PORTATARGA SX	L.H. NUMBER PLATE HOLDER	PORTE-PLAQUE GAUCHE	LINKS NUMMERSCHILDTAFEL	PORTA-MATRÍCULA IZQ.		1	
6	R95050091A	ROSETTA	WASHER	ROSETTE	UNTERLEGSSCHEIBE	ARANDELA		2	
7	R52840041A0	CATADIOTTRO	REFLECTOR	CATADIOPTRE	RÜCKSTRAHLER	CATADI ÓPTICO		1	
8	R300074216000	PORTATARGA DX	R.H. NUMBER PLATE HOLDER	PORTE-PLAQUE DROITE	RECHTS NUMMERSCHILDTAFEL	PORTA-MATRÍCULA DER.		1	
9	R95050012A	CLIP FISSAGGIO RAPIDO	QUIK FASTENING	FIXATION RAPIDE	SCHNELLBEFESTIGUNG	FIJACIÓN RÁPIDA		4	

PEDANE ANTERIORI

 PEDANE ANTERIORI

 FRONT FOOT PEG

 REPOSE PIEDS AVANT

 VORDERE FUSSRASTE

 ESTRIBERAS DELANTERA

TAVOLA
 DRAWING
 TABLE
 BILD
 TABLA

031



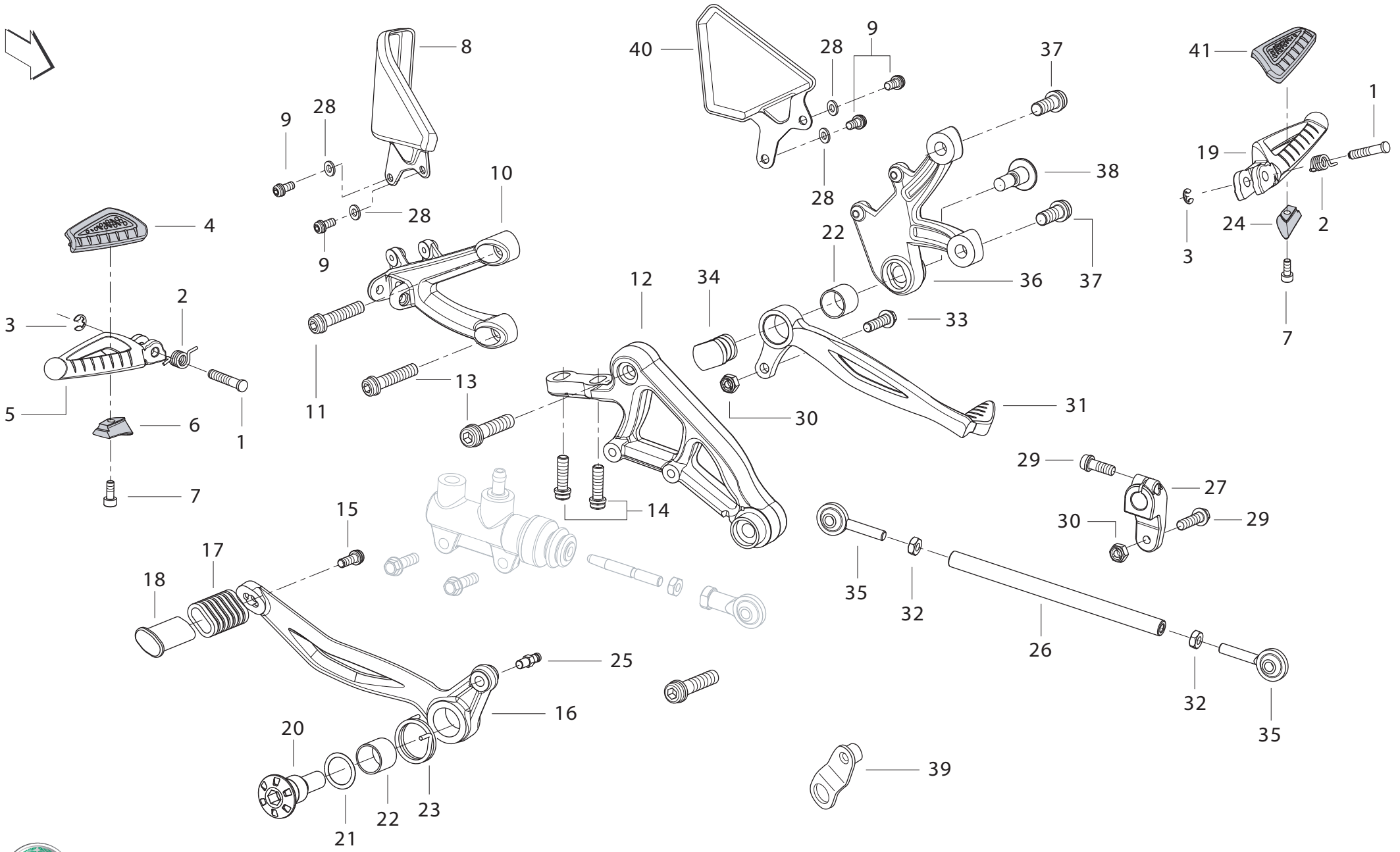

PEDANE ANTERIORI



FRONT FOOT PEG



REPOSE PIEDS AVANT



VORDERE FUSSRASTE



ESTRIBERAS DELANTERA



POS. NO. N. INDEX POS.	N. CODICE CODE NO. Nr. CODE ATRIKEL Nr. CODICO Nr.	DESCRIZIONE	DESCRIPTION	DESIGNATION	BEZEICHNUNG	DENOMINACION	NOTE NOTES NOTES MARKE NOTAS	Q.TA' Q.TY Q.TE M.GE C.AD
1	R21215031A	PERNO	PIN	PIVOT	ZAPFEN	PERNO		2
2	R21215121A	MOLLA	SPRING	RESSORT	FEDER	MUELLE		2
3	R92650088D	ANELLO SEEGER	CIRCLIP	CIRCLIP	SEEGERRING	ANILLO SEEGER		2
4	R300358030000	GOMMINO	RUBBER PAD	JOINT EN CAOUTCHOUC	GUMMISTÜCK	JUNTA DE GOMA		1
5	R3009580500W3	PEDANA ANTERIORE DX	FRONT R.H. FOOT PEG	REPOSE-PIED AVANT DROIT	VORDERE RECHTE FUSSRASTE	ESTRIBERA DELANTERA DER.		1
6	R300358026000	GOMMINO FISSAGGIO DX	R.H.FASTENING RUBBER PAD	JOINT EN CAOUTCHOUC FIXATION DROITE	BEFESTIGUNG GUMMISTÜCK RECHTE	JUNTA DE GOMA FIJACIÓN DER.		1
7	R90250192B	VITE	SCREW	VIS	SCHRAUBE	TORNILLO		2
8	R300059002000	PROTEZIONE PIEDE DX	R.H.PROTECTION FOOT	PIED DE PROTECTION DROIT	SCHUTZ-FUSS RECHTE	PIE DE LA PROTECCIÓN DER.		1
9	R90750402B	VITE	SCREW	VIS	SCHRAUBE	TORNILLO		4
10	R3000580000W3	PIASTRA PORTA PEDANA ANTERIORE DX	FRONT R.H. FOOT PEG HOLDER PLATE	PLAQUE PORTE-REPOSE-PIED AVANT DROITE	PLATTE FÜR FUßRASTENHALTER VORDERES RECHTER	SOPORTE ESTRIBERA DELANTERO DER.		1
11	R90752942B	VITE	SCREW	VIS	SCHRAUBE	TORNILLO		1
12	R3000500120W3	SUPPORTO POMPA FRENO	HOLDER BRAKE PUMP	POMPE FREIN SUPPORT	PUMPE BREMSE HALTERUNG	SOPORTE BOMBA FRENO		1
13	R90751472B	VITE	SCREW	VIS	SCHRAUBE	TORNILLO		2
14	R90750512B	VITE	SCREW	VIS	SCHRAUBE	TORNILLO		2
15	R180124019000	VITE	SCREW	VIS	SCHRAUBE	TORNILLO		1
16	R300058018000	LEVA COMANDO FRENO	BRAKE CONTROL LEVER	LEVIER DE COMMANDE FREIN	BREMSHEBEL	LEVA MANDO FRENO		1
17	R300058022000	GOMMINO	RUBBER PAD	JOINT EN CAOUTCHOUC	GUMMISTÜCK	JUNTA DE GOMA		1
18	R300058021000	PUNTALINO	RUNNER	BUTÉE	TASTBOLZEN	TRINQUETE		1
19	R3009580510W3	PEDANA ANTERIORE SX	FRONT L.H. FOOT PEG	REPOSE-PIED AVANT GAUCHE	VORDERE LINKE FUSSRASTE	ESTRIBERA DELANTERA IZQ.		1
20	R300052002000	PERNO PEDALE FRENO	BRAKE PEDAL PIN	AXE PÉDALE FREIN	PEDALSTIFT BREMSE	PERNO PEDAL FRENO		1
21	R21215391A	RONDELLA	WASHER	RONDELLE	UNTERLEGSCHIEBE	ARANDELA		1
22	R21215081A	BOCCOLA	BUSH	DOUILLE	BUCHSE	CASQUILLO		2
23	R300059000000	MOLLA	SPRING	RESSORT	FEDER	MUELLE		1
24	R300358029000	GOMMINO FISSAGGIO SX	L.H.FASTENING RUBBER PAD	JOINT EN CAOUTCHOUC FIXATION GAUCHE	BEFESTIGUNG GUMMISTÜCK LINKE	JUNTA DE GOMA FIJACIÓN IZQ.		1

PEDANE ANTERIORI

 PEDANE ANTERIORI

 FRONT FOOT PEG

 REPOSE PIEDS AVANT

 VORDERE FUSSRASTE

 ESTRIBERAS DELANTERA

TAVOLA
 DRAWING
 TABLE
 BILD
 TABLA

031

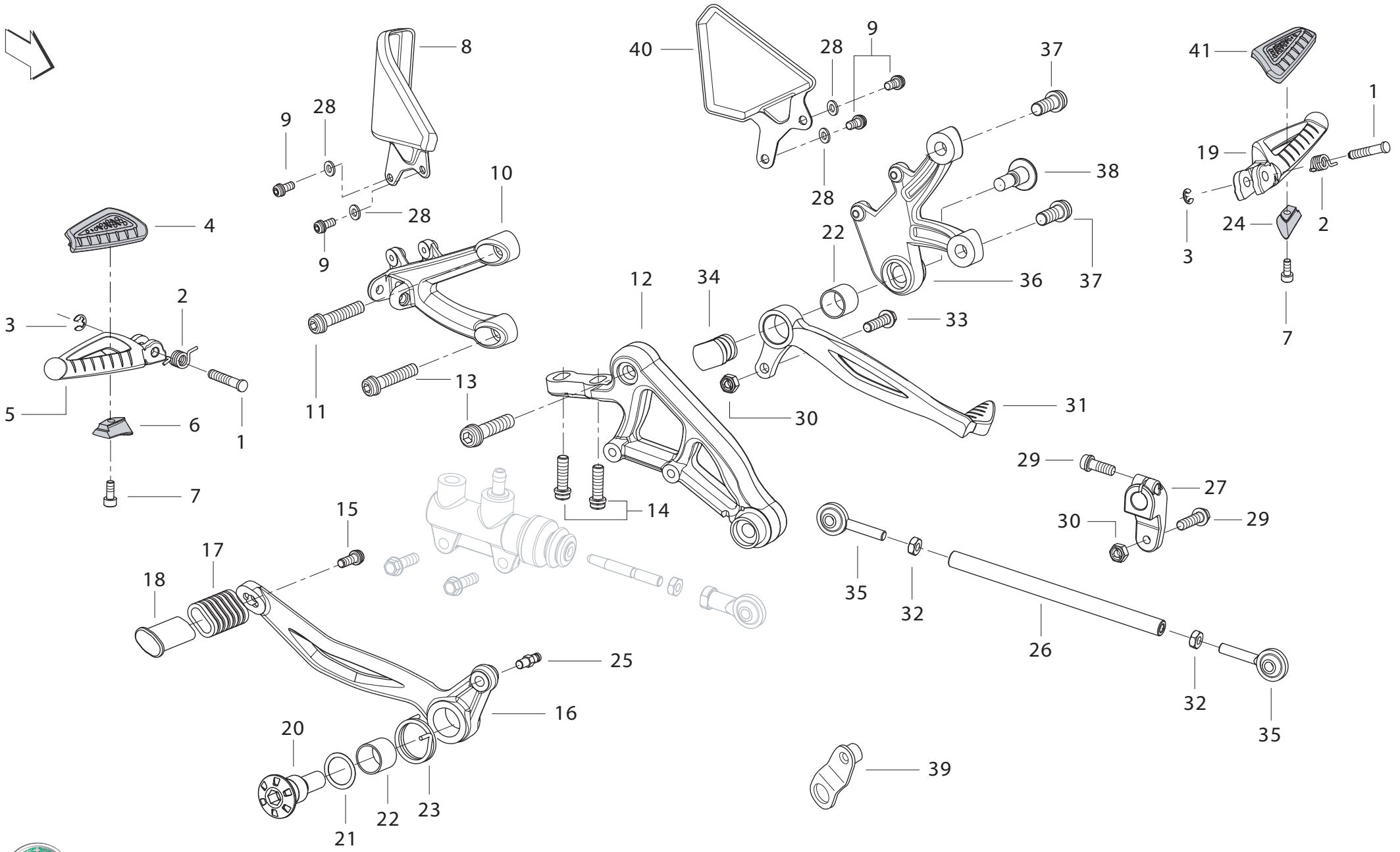



PEDANE ANTERIORI



FRONT FOOD PEG



REPOSE PIEDS AVANT



VORDERE FUSSRASTE



ESTRIBERAS DELANTERA

POS. NO. N. INDEX POS.	N. CODICE CODE NO. Nr. CODE ATRIKEL Nr. CODICO Nr.	DESCRIZIONE	DESCRIPTION	DESIGNATION	BEZEICHNUNG	DENOMINACION	NOTE NOTES NOTES MARKE NOTAS	Q.TA' Q.TY Q.TE M.GE C.AD	
25	R21215061A	PERNO MOLLA SUPERIORE	UPPER SPRING PIN	PIVOT MUELLE SUPÉRIEURE	ZAPFEN FEDER OBERER	PERNO MUELLE SUPERIOR		1	
26	R300026001000	ASTA RINVIO	TRANSMISSION ROD	TIGE RENVOI	GELENKSTIFT? RÜCKLEITUNG	ASTA TRANSMISIÓN		1	
27	R21813811A	BIELLA RINVIO	TRANSMISSION CONNECTING ROD	BIELLE RENVOI	KOLBEN RÜCKLEITUNG	BIELA TRANSMISIÓN		1	
28	R92050132A	RONDELLA	WASHER	RONDELLE	UNTERLEGSSCHEIBE	ARANDELA		4	
29	R90750502B	VITE	SCREW	VIS	SCHRAUBE	TORNILLO		2	
30	R91750032B	DADO	NUT	ECROU	MUTTER	TUERCA		2	
31	R180258008000	PEDALE CAMBIO	GEARBOX PEDAL	PÉDALE BOÎTE DE VITESSES	PEDAL SCHALTUNG	PEDAL CAMBIO		1	
32	R91551022B	DADO	NUT	ECROU	MUTTER	TUERCA		2	
33	R90750692B	VITE	SCREW	VIS	SCHRAUBE	TORNILLO		1	
34	R300052005000	PERNO PEDALE CAMBIO	GEARBOX PEDAL PIN	PIVOT PÉDALE BOÎTE DE VITESSES	ZAPFEN PEDAL SCHALTUNG	PERNO PEDAL CAMBIO		1	
35	R21813861A	TESTA A SNODO	JOINT HEAD	CULASSE JOINT	GELENK KOPF	CULATA ARTICULACIÓN		2	
36	R3000580010W3	PIASTRA PORTA PEDANA ANTERIORE SX	FRONT L.H.FOOT PEG HOLDER PLATE	PLAQUE PORTE-REPOSE-PIED AVANT GAUCHE	PLATTE FÜR FUßRASTENHALTER VORDERES LINKE	SOPORTE ESTRIBERA DELANTERO IZQ.		1	
37	R90751432B	VITE	SCREW	VIS	SCHRAUBE	TORNILLO		2	
38	R300052006000	VITE PEDALE CAMBIO	GEARBOX PEDAL SCREW	VIS PÉDALE BOÎTE DE VITESSES	SCHRAUBE PEDAL SCHALTUNG	TORNILLO PEDAL CAMBIO		1	
39	R300086133000	SUPPORTO MARMITTA	EXHAUST BOX HOLDER	SUPPORT POT	HALTERUNG AUSPUFFTOPF	SOPORTE SILENCIADOR		1	
40	R300059001000	PROTEZIONE PIEDE SX	L.H.PROTECTION FOOT	PIED DE PROTECTION GAUCHE	SCHUTZ-FUSS LINKS	PIE DE LA PROTECCIÓN IZQ.		1	
41	R300358025000	GOMMINO	RUBBER PAD	JOINT EN CAOUTCHOUC	GUMMISTÜCK	JUNTA DE GOMA		1	

PEDANE POSTERIORI



PEDANE POSTERIORI



REAR FOOT PEG



REPOSE PIED ARRIÈRE



HINTERE FUSSRASTE



ESTRIBERAS TRASERA

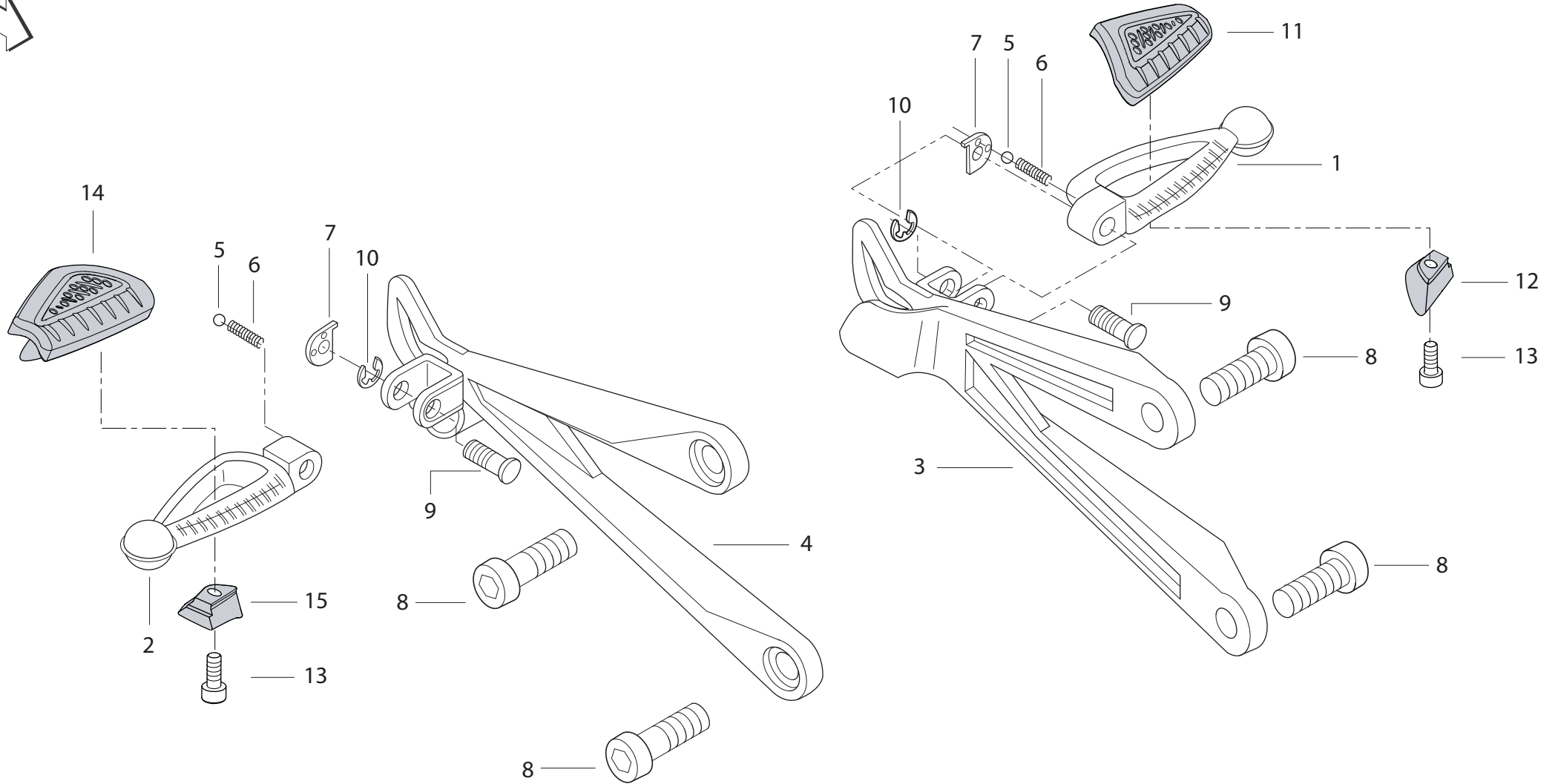



PEDANE POSTERIORI



REAR FOOT PEG



REPOSE PIED ARRIÈRE



HINTERE FUSSRASTE



ESTRIBERAS TRASERA

POS. NO. INDEX POS.	N. CODICE CODE NO. Nr. CODE ATRIKEL Nr. CODICO Nr.	DESCRIZIONE	DESCRIPTION	DESIGNATION	BEZEICHNUNG	DENOMINACION	NOTE NOTES NOTES MARKE NOTAS	Q.TA' Q.TY Q.TE M.GE C.AD	
1	R1802580030W3	PEDANA POSTERIORE SX	REAR L.H. FOOT PEG	REPOSE-PIED AR. GAUCHE	HINTERE FUSSRASTE LINKS	ESTRIBERA TRASERA IZQ.		1	
2	R1802580040W3	PEDANA POSTERIORE DX	REAR R.H. FOOT PEG	REPOSE-PIED AR. DROITE	HINTERE FUSSRASTE RECHTS	ESTRIBERA TRASERA DER.		1	
3	R1802580050W3	PIASTRA PORTAPEDANA SX	L.H. FOOT PEG HOLDER PLATE	PLAQUE PORTE-REPOSE-PIED GAUCHE	PLATTE FÜR FUßRASTENHALTER LINKER	SOPORTE ESTRIBERA IZQ.		1	
4	R1802580060W3	PIASTRA PORTAPEDANA DX	R.H. FOOT PEG HOLDER PLATE	PLAQUE PORTE-REPOSE-PIED DROITE	PLATTE FÜR FUßRASTENHALTER RECHER	SOPORTE ESTRIBERA DER.		1	
5	R26110101A	SFERA	BALL	BILLE	KUGEL	ESFERA		2	
6	R26110091A	MOLLA	SPRING	RESSORT	FEDER	MUELLE		2	
7	R180258007000	PIASTRINO	PLATE	PLAQUETTE	PLÄTTCHEN	LÁMINA		2	
8	R90751422B	VITE	SCREW	VIS	SCHRAUBE	TORNILLO		4	
9	R21215031A	PERNO	PIN	PIVOT	ZAPFEN	PERNO		2	
10	R92650088D	ANELLO ELASTICO	SNAP RING	BAGUE ÉLASTIQUE	SPRENGRING	SEAGER		2	
11	R300358025000	COPRIPIEDANA IN GOMMA SX	L.H. FOOT PEG RUBBER COVER	COUVRE-REPOSE-PIED EN CAOUTCHOUC GAUCHE	FUßSTÜTZENVERKLEIDUNG AUS GUMMI LINKER	COBERTURA APOYA-PIES DE GOMA IZQ.		1	
12	R300358029000	FERMO GOMMA PEDANA SX	L.H. FIXED RUBBER	LE CAOUTCHOUC FIXE GAUCHE	ÖRTLICH FESTGELEGTER GUMMI GAUCHE	CAUCHO FIJO IZQ.		1	
13	R90250192B	VITE	SCREW	VIS	SCHRAUBE	TORNILLO		2	
14	R300358030000	COPRIPIEDANA IN GOMMA DX	R.H. FOOT PEG RUBBER COVER	COUVRE-REPOSE-PIED EN CAOUTCHOUC DROITE	FUßSTÜTZENVERKLEIDUNG AUS GUMMI RECHTER	COBERTURA APOYA-PIES DE GOMA DER.		1	
15	R300358026000	FERMO GOMMA PEDANA DX	R.H. FIXED RUBBER	LE CAOUTCHOUC FIXE DROITE	ÖRTLICH FESTGELEGTER GUMMI RECHTER	CAUCHO FIJO DER.		1	

PARAFANGO ANTERIORE

PARAFANGO ANTERIORE

FRONT MUDGUARD

GARDE-BOUE AVANT

VORDERES SCHUTZBLECH

GUARDABARROS DELANTERO

TAVOLA
DRAWING
TABLE
BILD
TABLA

033

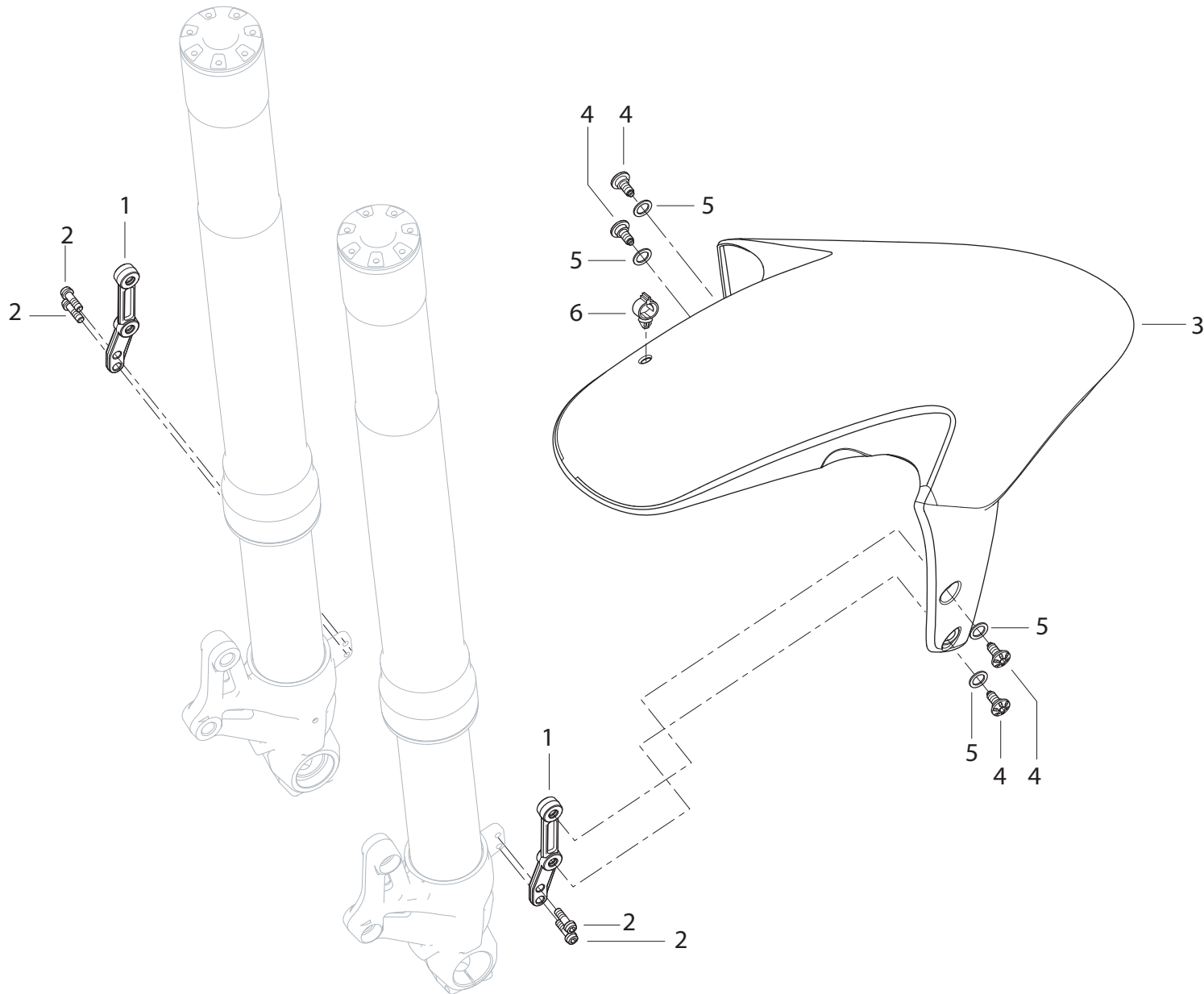

POS. NO. N. INDEX POS.	N. CODICE CODE NO. Nr. CODE ATRIKEL Nr. CODICO Nr.	DESCRIZIONE	DESCRIPTION	DESIGNATION	BEZEICHNUNG	DENOMINACION	NOTE NOTES MARKE NOTAS	Q.TA' Q.TY Q.TE M.GE C.AD	
1	R180257138000	STAFFA	BRACKET	BRIDE	BÜGEL	SOPORTE		2	
2	R90750412B	VITE	SCREW	VIS	SCHRAUBE	TORNILLO		4	
3	R21814601A	PARAFANGO ANTERIORE	FRONT MUDGUARD	GARDE-BOUE AVANT	VORDERES SCHUTZBLECH	GUARDABARROS DELANTERO		1	
4	R90752268E	VITE SPECIALE	SPECIAL SCREW	VIS SPÉCIALE	SPEZIALSCHRAUBE	TORNILLO ESPECIAL		4	
5	R90752302B	ROSETTA NYLON	NYLON WASHER	ROSETTE EN NYLON	NYLON-UNTERLEGSCHIEBE	ARANDELA NYLON		4	
6	R300068102000	FERMATUBO	PIPE STOP	ARRET TUBE	SCHLAUCHHALTERUNG	PASADOR TUBO		1	

FORCELLA ANTERIORE



FORCELLA ANTERIORE



FRONT FORK



FOURCHE AVANT



TELEGABEL



HORQUILLA DELANTERA

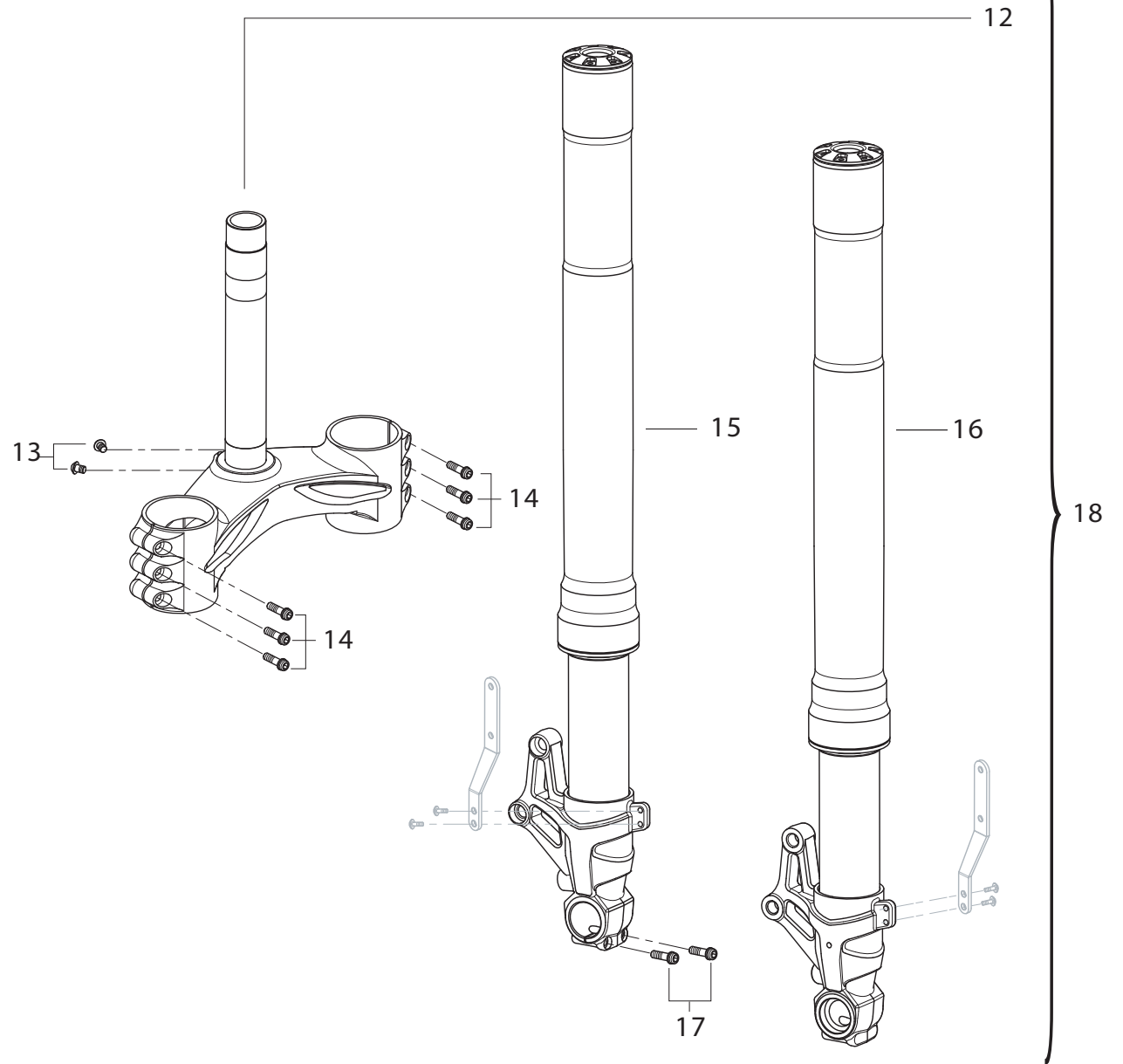
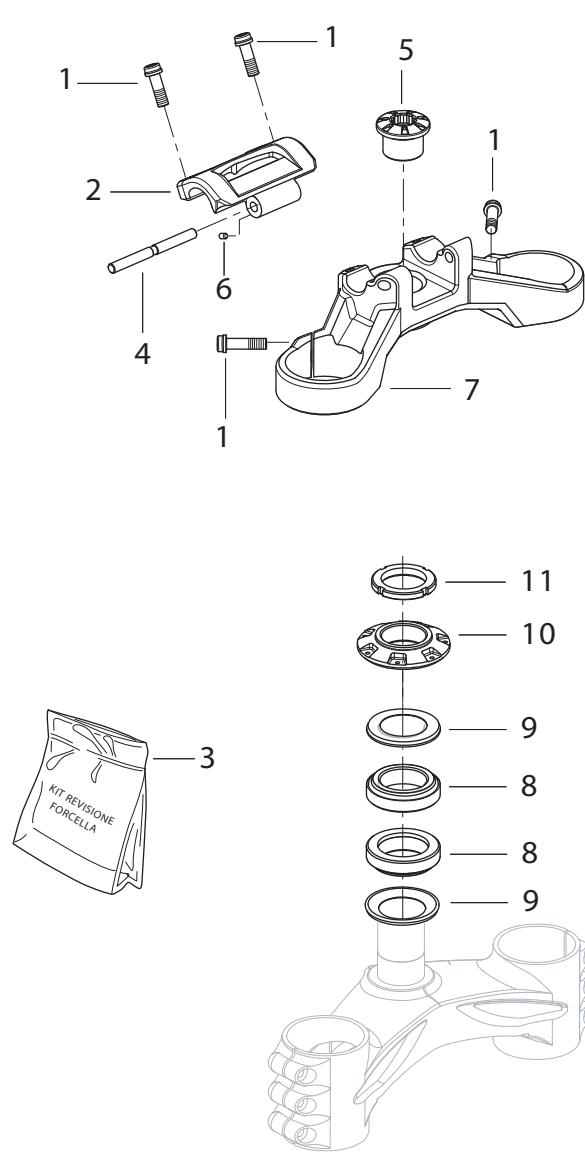

POS. NO. N. INDEX POS.	N. CODICE CODE NO. Nr. CODE ATRIKEL Nr. CODICO Nr.	DESCRIZIONE	DESCRIPTION	DESIGNATION	BEZEICHNUNG	DENOMINACION	NOTE NOTES NOTES MARKE NOTAS	Q.TA' Q.TY Q.TE M.GE C.AD	
1	R90751452B	VITE	SCREW	VIS	SCHRAUBE	TORNILLO		4	
2	R30036902100X	CAVALLOTTO MANUBRIO	HANDLEBAR BRACKET	CAVALIER GUIDON	BÜGELBOLZEN LENKER	PERNO DE U		1	
3	R300000157000	KIT REVISIONE FORCELLA	FORK OVERHAUL KIT	KIT RÉVISION FOURCHE	REPARATURKIT TELEGABEL	KIT REVISIÓN HORQUILLA		1	
4	R300052008000	PERNO	PIN	PIVOT	ZAPFEN	PERNO		1	
5	R21413141A	VITE SPECIALE	SPECIAL SCREW	VIS SPÉCIALE	SPEZIALSCHRAUBE	TORNILLO ESPECIAL		1	
6	R92950352B	GRANO	DOWEL	VIS SANS TÊTE	STIFT	CLAVIJA		1	
7	R30036900700X	TESTA DI STERZO	STEERING HEAD	TÊTE DE DIRECTION	GABELKOPF	TIJA SUPERIOR		1	
8	R21413021A	CUSCINETTO	BEARING	ROULEMENT	LAGER	COJINETE		2	
9	R21413031A	ANELLO PARAPOLVERE	DUST PROTECTION RING	PARE-POUSSIÈRE	STAUBSCHUTZRING	ANILLO GUARDAPOLVO		2	
10	R180269004000	GHIERA DI STERZO	STEERING RING NUT	BAGUE DE DIRECTION	LENKUNGSZAPFEN	ZUNCHO DE DIRECCIÓN		1	
11	R21413171A	GHIERA PERNO DI STERZO	STEERING RING NUT PIN	BAGUE PIVOT DE DIRECTION	LENKUNGSZAPFEN-NUTMUTTER	ZUNCHO PERNO DE DIRECCIÓN		1	
12	R180469017000	BASE DI STERZO	STEERING HEAD BASE	BASE DE DIRECTION	GABELKOPF	TIJA INFERIOR		1	
13	R90750472B	VITE	SCREW	VIS	SCHRAUBE	TORNILLO		2	
14	R90750512B	VITE	SCREW	VIS	SCHRAUBE	TORNILLO		6	
15	R300069006001	ASSIEME GAMBA DX	R.H.FORK LEG ASSEMBLY	ENSEMBLE FOURCHE DROITE	RECHTES FEDERBEIN KOMPLETT	TUBO HORQUILLA DER.		1	
16	R300069005001	ASSIEME GAMBA SX	L.H.FORK LEG ASSEMBLY	ENSEMBLE FOURCHE GAUCHE	LINKES FEDERBEIN KOMPLETT	TUBO HORQUILLA IZQ.		1	
17	R90750532B	VITE	SCREW	VIS	SCHRAUBE	TORNILLO		2	
18	R300069000001	FORCELLA ANTERIORE COMPLETA	COMPLETE FRONT FORK	FOURCHE AVANT COMPLÈTE	KOMPLETTE TELEGABEL	HORQUILLA DELANTERA COMPLETA		1	

MANUBRIO E COMANDI

 MANUBRIO
E COMANDI

 HANDLEBAR
AND CONTROLS

 GUIDON ET
COMANDES

 LENKER UND
STEUERORGANE

 MANILLARY MANDOS

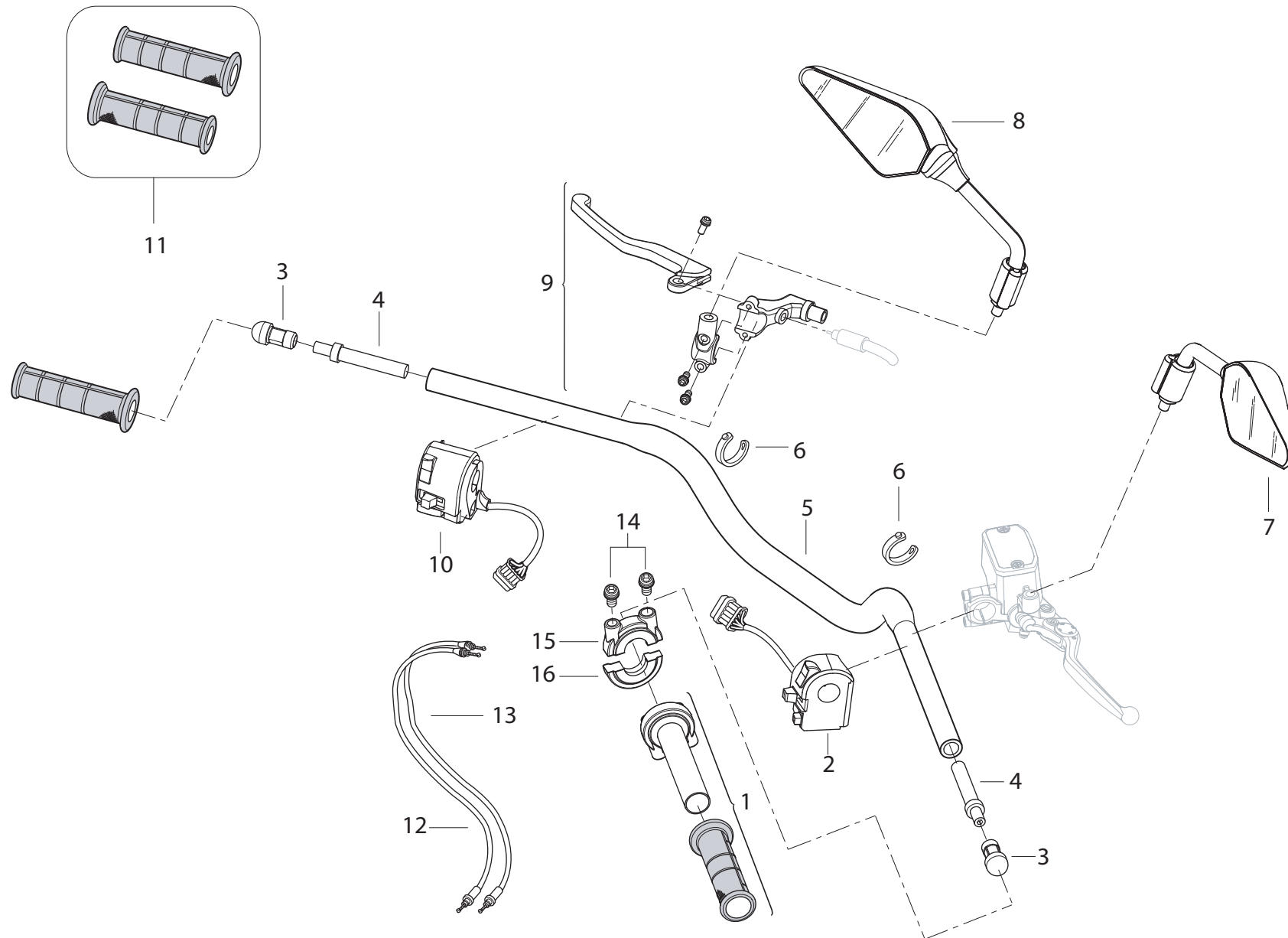

POS. NO. INDEX POS.	N. CODICE CODE NO. Nr. CODE ATRIKEL Nr. CODICO Nr.	DESCRIZIONE	DESCRIPTION	DESIGNATION	BEZEICHNUNG	DENOMINACION	NOTE NOTES NOTES MARKE NOTAS	Q.TA' Q.TY Q.TE M.GE C.AD	
1	R21413291A	COMANDO GAS	THROTTLE CONTROL	CONTRÔLE GAZ	GASSTEUERUNG	MANDO ACELERADOR		1	
2	R300062110000	COMMUTATORE DX	R.H. SWITCH	COMMUTATEUR DROIT	RECHTER LENKERSCHALTER	COMMUTADOR DER.		1	
3	R180279170000	TAPPO	CAP	BOUCHON	VERSCHLUB	TAPÓN		2	
4	R300061003000	TERMINALE MANOPOLA	HAND GRIP TERMINAL	TERMINAISON POIGNÉE	ENDSTÜCK GRIFF	TERMINAL PUÑO		2	
5	R300956000000	MANUBRIO	HANDLEBAR	GUIDON	LENKER	MANILLAR		1	
6	R22640041AZ	FASCETTA IN GOMMA	RUBBER HOSE CLAMP	COLLIER EN CAOUTCHOUC	GUMMISCHELLE	ABRAZADERA EN GOMA		2	
7	R300092000000	SPECCHIO RETROVISORE DX	R.H. REAR-VIEW MIRROR	RÉTROVISEUR DROIT	RECHER RÜCKSPIEGEL	ESPEJO RETROVISOR DER.		1	
8	R300092001000	SPECCHIO RETROVISORE SX	L.H. REAR-VIEW MIRROR	RÉTROVISEUR GAUCHE	LINKER RÜCKSPIEGEL	ESPEJO RETROVISOR IZQ.		1	
9	R300065002000	LEVA COMANDO FRIZIONE	CLUTCH CONTROL LEVER	LEVIER DE COMMANDE EMRAYAGE	KUPPLUNGSHABEL	LEVA MANDO EMBRAGUE		1	
10	R300062109000	COMMUTATORE SX	L.H. SWITCH	COMMUTATEUR GAUCHE	LINKER LENKERSCHALTER	COMMUTADOR IZQ.		1	
11	R180200170000	COPPIA MANOPOLE	GRIPS PAIR	JEU DE POIGNÉES	GRIFFPAAR	PAR PUÑOS		1	
12	R180260104000	CAVO APERTURA GAS	THROTTLE OPENING CABLE	CÂBLE OVERTURE GAZ	GASÖFFNUNGSKABEL	CABLE ABERTURA ACELERADOR		1	
13	R180260106000	CAVO CHIUSURA GAS	THROTTLE CLOSING CABLE	CÂBLE FERMETURE GAZ	GASCHLIEßKABEL	CABLE CIERRE ACELERADOR		1	
14	R22640031A0	VITE	SCREW	VIS	SCHRAUBE	TORNILLO		2	
15	R21413311A	COPERCHIO ANTERIORE	FRONT COVER	COUVERCLE AVANT	VORDERE DECKEL	TAPA DELANTERA		1	
16	R21413321A	COPERCHIO POSTERIORE	REAR COVER	COUVERCLE ARRIÈRE	HITERE DECKEL	TAPA TRASERA		1	

FRENO ANTERIORE

 FRENO ANTERIORE

 FRONT BRAKE

 FREIN AVANT

 VORD BREMSE

 FRENO DELANTERO

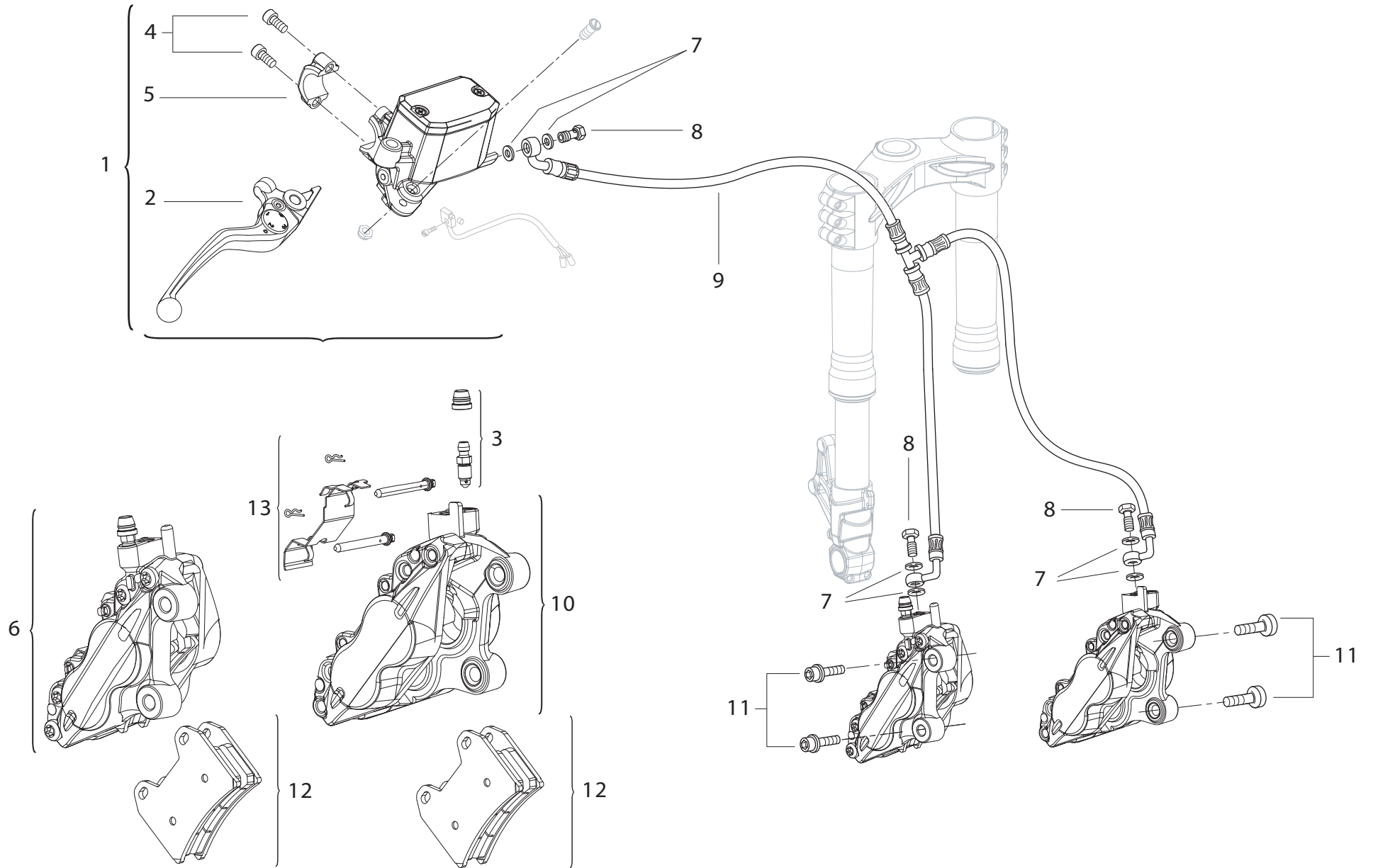

POS. NO. N. INDEX POS.	N. CODICE CODE NO. Nr. CODE ATRIKEL Nr. CODICO Nr.	DESCRIZIONE	DESCRIPTION	DESIGNATION	BEZEICHNUNG	DENOMINACION	NOTE NOTES MARKE NOTAS	Q.TA' Q.TY Q.TE M.GE C.AD	
1	R300063000000	POMPA FRENO ANTERIORE	FRONT BRAKE PUMP	POMPE FREIN AVANT	PUMPE FÜR VORDERRADBREMSE	BOMBA FRENO DELANTERO		1	
2	R300063104000	LEVA COMANDO FRENO	BRAKE CONTROL LEVER	LEVIER DE COMMANDE FREIN	BREMSHEBEL	LEVA MANDO FRENO		1	
3	R310000186000	SPURGO	BLEED	VIDANGE	ABLAß	PURGA		1	
4	R90750692B	VITE	SCREW	VIS	SCHRAUBE	TORNILLO		2	
5	R300063105000	CAVALLOTTO	BRACKET	CAVALIER	BÜGELBOLZEN	PERNO DE U		1	
6	R300063004000	PINZA FRENO DX	R.H. BRAKE CALIPER	PINCE FREIN DROIT	RECHTE BREMSZANGE	PINZA FRENO DERECHA		1	
7	R180264003000	GUARNIZIONE	GASKET	GARNITURE	DICHTUNG	JUNTA		6	
8	R180264002000	VITE SPECIALE	SPECIAL SCREW	VIS SPÉCIALE	SPEZIALSCHRAUBE	TORNILLO ESPECIAL		3	
9	R300064100000	TUBO FRENO ANTERIORE	FRONT BRAKE LINE	TUBE FREIN AVANT	VORDERE BREMSLEITUNG	TUBO FRENO DELANTERO		1	
10	R300063005000	PINZA FRENO SX	L.H. BRAKE CALIPER	PINCE FREIN GAUCHE	LINKE BREMSZANGE	PINZA FRENO IZQ.		1	
11	R21215231A	VITE	SCREW	VIS	SCHRAUBE	TORNILLO		4	
12	R300000126000	COPPIA PASTIGLIE	PADS PAIR	PAIRE DE PLAQUETTES	PAAR BREMSBELÄGE	PAR PASTILLAS		2	
13	R300063016000	RICAMBIO PERNI E MOLLETTA	SPARE PINS AND SPRING	GOIJONS ET RESSORT	ERSATZTEILE BOLZEN MIT FEDER	RECAMBIOS PERNOS Y RESORTE		1	

FRENO POSTERIORE

 FRENO POSTERIORE

 REAR BRAKE

 FREIN ARRIERE

 HINTERBREMSE

 FRENO TRASERO

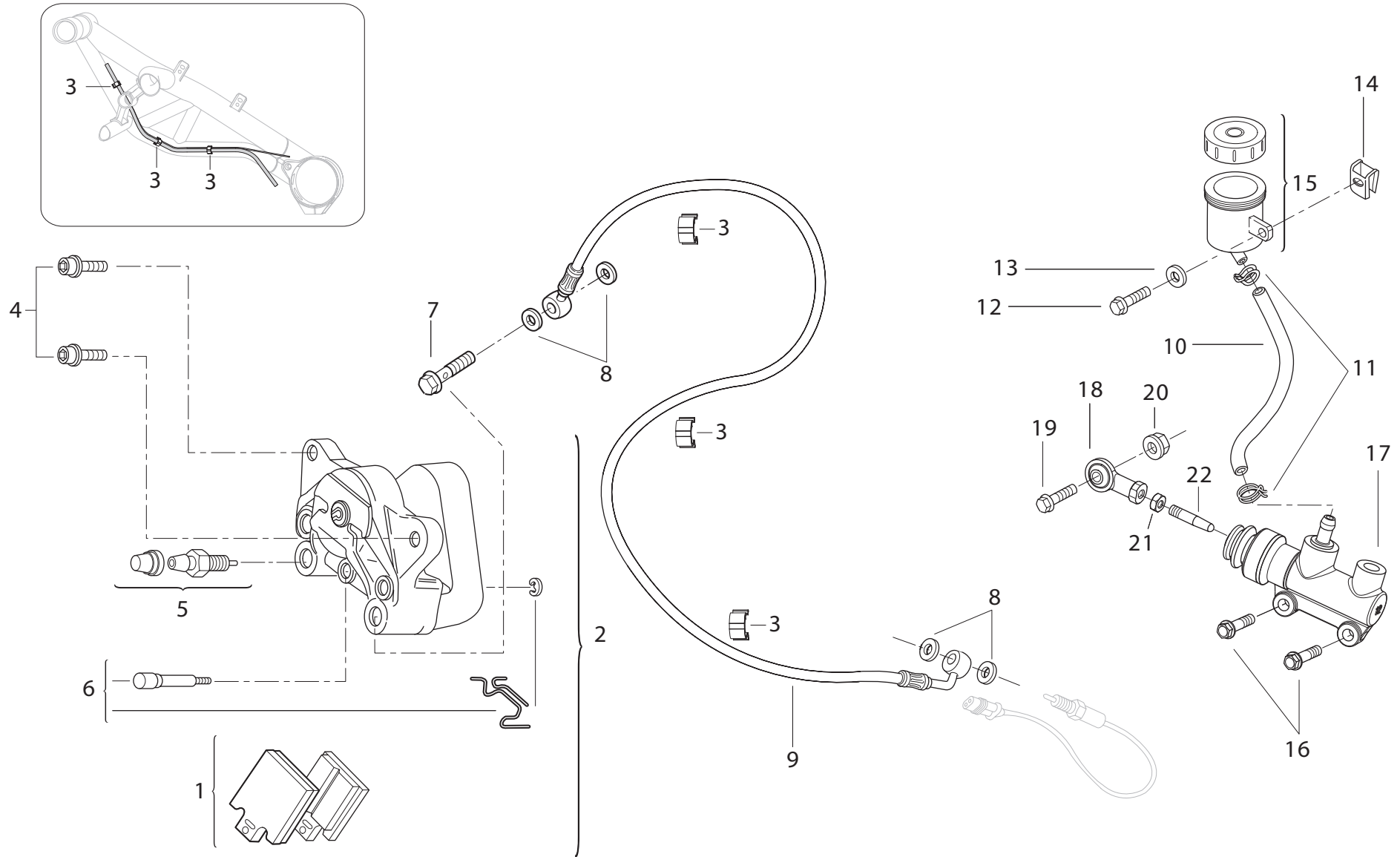

POS. NO. INDEX POS.	N. CODICE CODE NO. Nr. CODE ATRIKEL Nr. CODICO Nr.	DESCRIZIONE	DESCRIPTION	DESIGNATION	BEZEICHNUNG	DENOMINACION	NOTE NOTES NOTES MARKE NOTAS	Q.TA' Q.TY Q.TE M.GE C.AD	
1	R44422001A	COPPIA PASTIGLIE	PADS PAIR	PAIRE DE PLAQUETTES	PAAR BREMSBELÄGE	PAR PASTILLAS		1	
2	R44343001A	PINZA FRENO POSTERIORE	REAR BRAKE CALIPER	PINCE FREIN ARRIÈRE	HITERE BREMSZANGE	PINZA FRENO TRASERO		1	
3	R300063124000	PASSACAVO	FAIRLEAD	PASSE-CÂBLE	KABELDURCHFÜHRUNG	PASA-CABLE		3	
4	R90751432B	VITE	SCREW	VIS	SCHRAUBE	TORNILLO		2	
5	R310000186000	SPURGO	BLEED	VIDANGE	ABLAß	PURGA		1	
6	R310000187000	RICAMBIO PERNI E MOLLETTA	SPARE PINS AND SPRING	KIT GOUJONS ET RESSORT	ERSATZTEILE BOLZEN MIT FEDER	RECAMBIOS PERNOS Y RESORTE		1	
7	R180464002000	VITE SPECIALE	SPECIAL SCREW	VIS SPÉCIALE	SPEZIALSCHRAUBE	TORNILLO ESPECIAL		1	
8	R180264003000	GUARNIZIONE	GASKET	GARNITURE	DICHTUNG	JUNTA		4	
9	R300064101000	TUBO FRENO POSTERIORE	REAR BRAKE LINE	TUBE FREIN ARRIÈRE	HINTERE BREMSLEITUNG	TUBO FRENO TRASERO		1	
10	R180164001255	TUBO	TUBE	TUBE	ROHR	TUBO		1	
11	R95251013B	FASCETTA A MOLLA	SPRING HOSE CLAMP	COLLIER À RESSORT	FEDERSCHELLE	ABRAZADERA A MUELLE		2	
12	R90750502B	VITE	SCREW	VIS	SCHRAUBE	TORNILLO		1	
13	R92050152B	RONDELLA	WASHER	RONDELLE	UNTERLEGSCHLEIBE	ARANDELA		1	
14	R95050012A	CLIP FISSAGGIO RAPIDO	QUIK FASTENING	FIXATION RAPIDE	SCHNELLEBEFESTIGUNG	FIJACIÓN RÁPIDA		1	
15	R21413271A	SERBATOIO OLIO COMPLETO	COMPLETE OIL TANK	RÉSERVOIR D' HUILE COMPLET	KOMPLETTER ÖLTANK	DEPÓSITO ACEITE COMPLETO		1	
16	R90750672B	VITE	SCREW	VIS	SCHRAUBE	TORNILLO		2	
17	R180263007000	POMPA FRENO POSTERIORE	REAR BRAKE PUMP	POMPE FREIN ARRIÈRE	PUMPE FÜR HITERRADBREMSE	BOMBA FRENO TRASERO		1	
18	R21813851A	SNODO SFERICO	BALL JOINT	JOINT À ROTULE	KUGELGELENK	ARTICULACIÓN ESFÉRICA		1	
19	R90750512B	VITE	SCREW	VIS	SCHRAUBE	TORNILLO		1	
20	R91750032B	DADO	NUT	ECROU	MUTTER	TUERCA		1	
21	R91551022B	DADO	NUT	ECROU	MUTTER	TUERCA		1	
22	R21215041A	ASTA DI REGISTRO	ADJUSTER ROD	TIGE DE RÉGLAGE	EINSTELLSTAB	VARILLA DE REGULACIÓN		1	

RUOTA ANTERIORE

 RUOTA ANTERIORE

 FRONT WHELL

 ROUE AVANT

 VORDERRAD

 RUEDA DELANTERA

TAVOLA
 DRAWING
 TABLE
 BILD
 TABLA

038

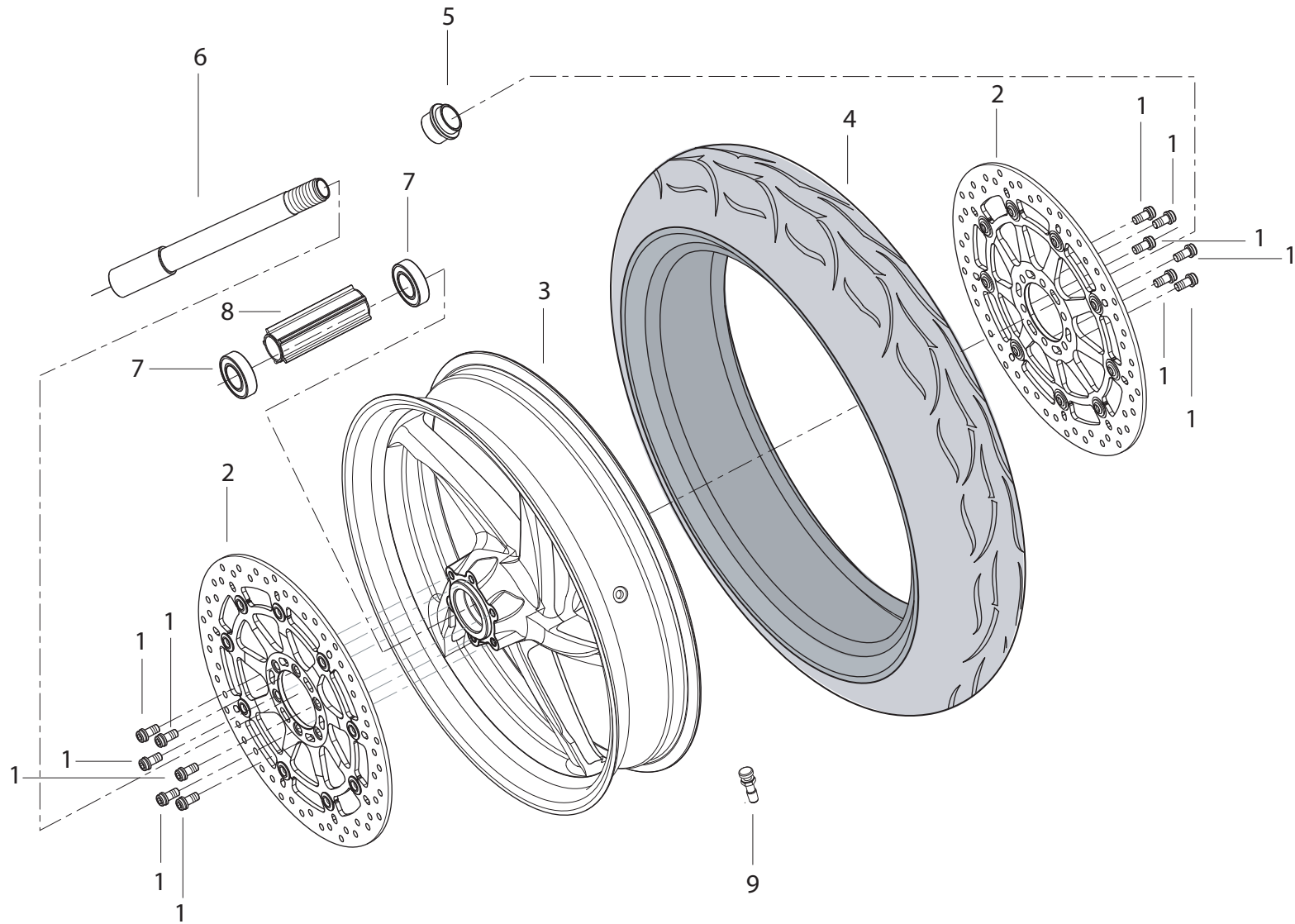

POS. NO. N. INDEX POS.	N. CODICE CODE NO. Nr. CODE ATRIKEL Nr. CODICO Nr.	DESCRIZIONE	DESCRIPTION	DESIGNATION	BEZEICHNUNG	DENOMINACION	NOTE NOTES NOTES MARKE NOTAS	Q.TA' Q.TY Q.TE M.GE C.AD	
1	R90751422B	VITE	SCREW	VIS	SCHRAUBE	TORNILLO		12	
2	R300071101000	DISCO FRENO ANTERIORE (Ø320)	FRONT BRAKE DISC (Ø320)	DISQUE FREIN AVANT (Ø320)	VORDERE BREMSSCHEIBE (Ø320)	DISCO FRENO DELANTERO (Ø320)		2	
3	R30037110500E	CERCHIO RUOTA ANTERIORE (NERO)	FRONT WHEEL RIM (BLACK)	JANTE ROUE AVANT (NOIR)	VORDERRADFELGE (SCHWARZ)	LLANTA RUEDA DELANTERA (NEGRO)		1	
4	R300071100000	PNEUMATICO ANTERIOIRE	FRONT TIRE	PNEU AVANT	VORDES REIFEN	NEUMÁTICO DELANTERO		1	
5	R180271116000	DISTANZIALE SINISTRO	L.H. SPACER	ENTRETOISE GAUCHE	LINKES DISTANZSTÜCK	DISTANCIADOR IZQ.		1	
6	R180471107000	PERNO RUOTA ANTERIORE	FRONT WHEEL SPINDLE	PIVOT ROUE AV.	VORDERRADZAPFEN	PERNO RUEDA DELANTERA		1	
7	R21215201A	CUSCINETTO	BEARING	ROULEMENT	LAGER	COJINETE		2	
8	R180271104000	DISTANZIALE INTERNO	INNER SPACER	ENTRETOISE INTERNE	INNERES DISTANZSTÜCK	DISTANCIADOR INTERIOR		1	
9	R180272108000	VALVOLA	VALVE	SOUPAPE	VENTIL	VÁLVULA		1	

RUOTA POSTERIORE

 RUOTA POSTERIORE

 REAR WHEEL

 ROUE ARRIÈRE

 HINTERRAD

 RUEDA TRASERA

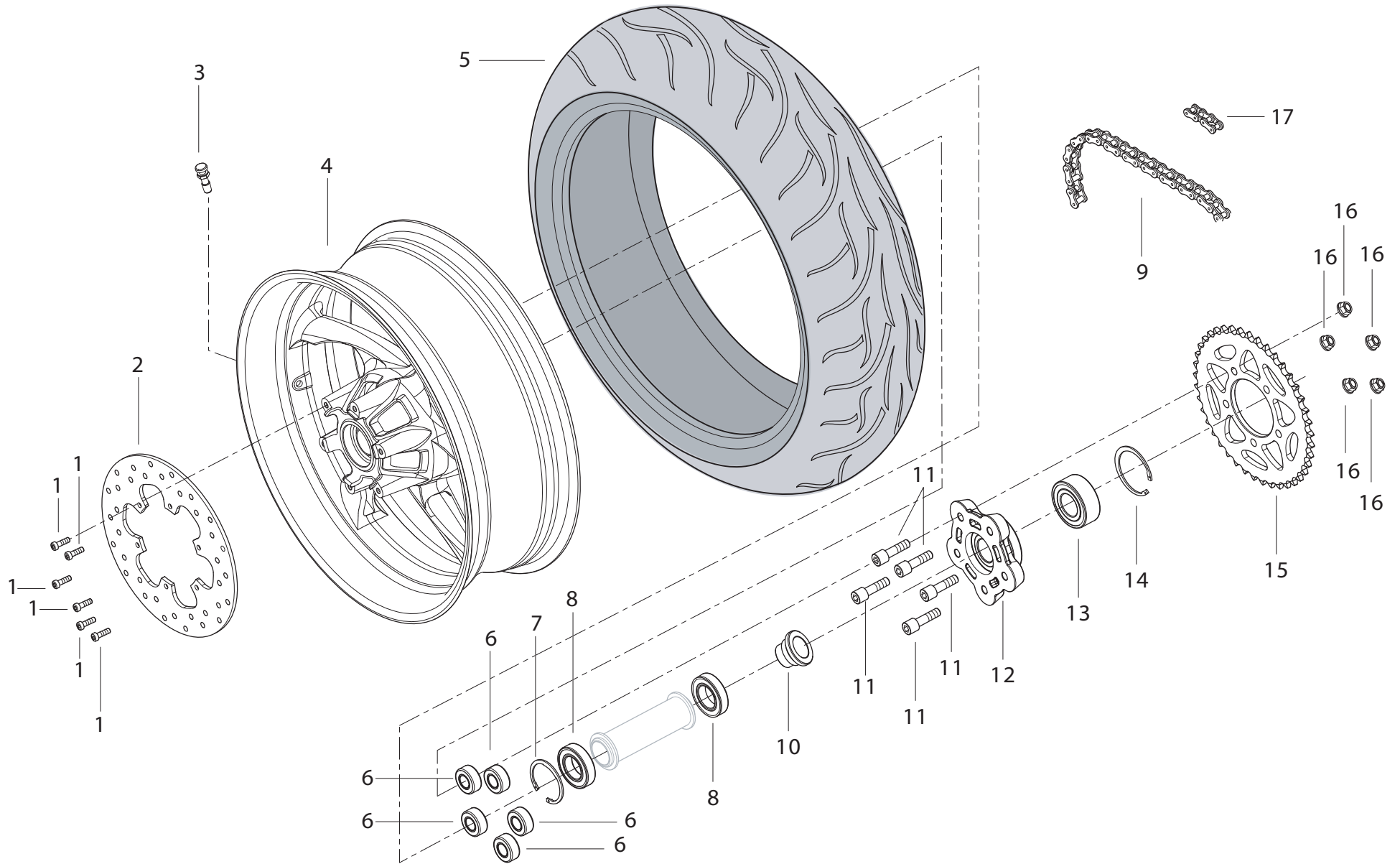

POS. NO. N. INDEX POS.	N. CODICE CODE NO. Nr. CODE ATRIKEL Nr. CODICO Nr.	DESCRIZIONE	DESCRIPTION	DESIGNATION	BEZEICHNUNG	DENOMINACION	NOTE NOTES NOTES MARKE NOTAS	Q.TA' Q.TY Q.TE M.GE C.AD	
1	R90350672C	VITE	SCREW	VIS	SCHRAUBE	TORNILLO		6	
2	R180272105000	DISCO FRENO POSTERIORE	REAR BRAKE DISC	DISQUE FREIN AR.	HINTERE BREMSSCHEIBE	DISCO FRENO TRASERO		1	
3	R180272108000	VALVOLA	VALVE	SOUPAPE	VENTIL	VÁLVULA		1	
4	R30037210100E	CERCHIO RUOTA POSTERIORE (NERO)	REAR WHEEL RIM (BLACK)	JANTE ROUE AR. (NOIR)	HINTERRADFELGE (SCHWARZ)	LLANTA RUEDA TRASERA (NEGRO)		1	
5	R300072100000	PNEUMATICO POSTERIORE	REAR TIRE	PNEU ARRIÈRE	HINTER REIFEN	NEUMÁTICO TRASERO		1	
6	R180272109000	GOMMA PARASTRAPPI	SPRING DRIVE RUBBER	CAOUTCHOUC FLECTEUR	STOESSSCHUTZGUMMI	GOMA JUNTA AMORTIGÜADORA		5	
7	R21214961A	ANELLO ELASTICO	SNAP RING	BAGUE ÉLASTIQUE	SPRENGRING	SEAGER		1	
8	R180172114000	CUSCINETTO	BEARING	ROULEMENT	LAGER	COJINETE		2	
9	R300027001000	CATENA	CHAIN	CHAÎNE	KETTE	CADENA		1	
10	R180272117000	DISTANZIALE SINISTRO	L.H.SPACER	ENTRETOISE GAUCHE	LINKES DISTANZSTÜCK	DISTANCIADOR IZQ.		1	
11	R180272113000	VITE	SCREW	VIS	SCHRAUBE	TORNILLO		5	
12	R180272104000	FLANGIA PORTACORONA	REAR SPROCKET FLANGE	BRIDE PORTE-COURONNE	KRANZHALTEFLANSCH	BRIDA PORTA-CORONA		1	
13	R180272115000	DISTANZIALE	SPACER	ENTRETOISE	DISTANZSTÜCK	DISTANCIAL		1	
14	R92652620D	ANELLO ELASTICO	SNAP RING	BAGUE ÉLASTIQUE	SPRENGRING	SEAGER		1	
15	R300027029000	CORONA Z36	RING GEAR Z36	COURONNE Z36	KRANZ Z36	CORONA Z36		1	
16	R91350092B	DADO	NUT	ECROU	MUTTER	TUERCA		5	
17	R180227030000	MAGLIA GIUNZIONE CATENA (REGINA ARGENTO)	CHAIN SECTOR	SECTEUR À CHAÎNE	KETTENSEKTOR	SECTOR DE CADENA		1	
17	R310027030000	MAGLIA GIUNZIONE CATENA (RK)	CHAIN SECTOR	SECTEUR À CHAÎNE	KETTENSEKTOR	SECTOR DE CADENA		1	

CUPOLINO

🇮🇹 CUPOLINO

🇬🇧 HEADLIGHT FAIRING

🇫🇷 CARÉPAGE

🇩🇪 FAHRTWINDSCHUTZ

🇪🇸 CÚPULA

TAVOLA
DRAWING
TABLE
BILD
TABLA

040

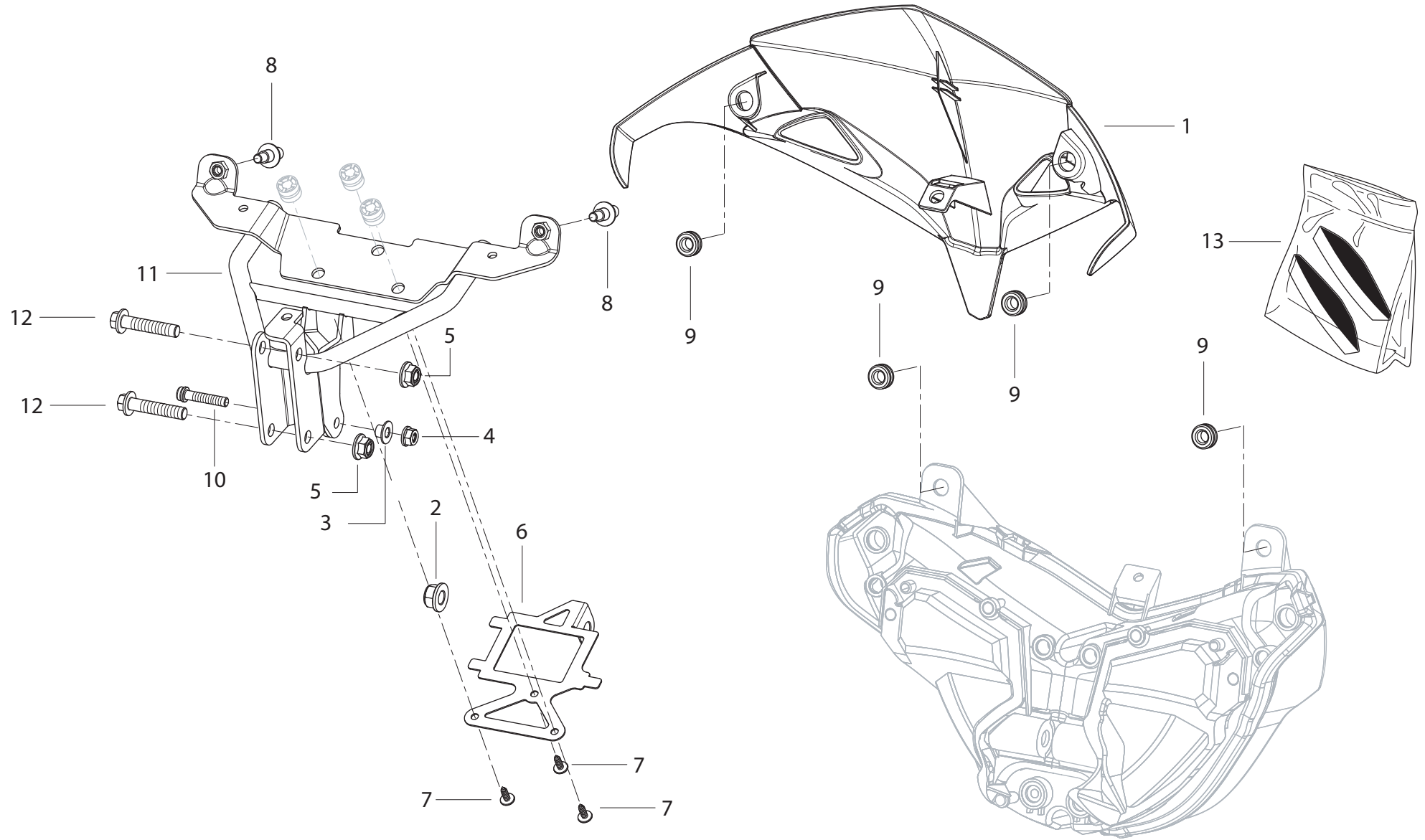

POS. NO. N. INDEX POS.	N. CODICE CODE NO. Nr. CODE ATRIKEL Nr. CODICO Nr.	DESCRIZIONE	DESCRIPTION	DESIGNATION	BEZEICHNUNG	DENOMINACION	NOTE NOTES NOTES MARKE NOTAS	Q.TA' Q.TY Q.TE M.GE C.AD	
1	R3009960000CB	CUPOLINO	HEADLIGHT FAIRING	CARÉNAGE	FAHRTWINDSCHUTZ	CÚPULA		1	
1	R3009960001CL	CUPOLINO (NERO DARK)	HEADLIGHT FAIRING (BLACK DARK)	CARÉNAGE (NOIR DARK)	FAHRTWINDSCHUTZ (SCHWARZ DARK)	CÚPULA (NEGRO DARK)	MY 2009	1	
2	R91350092B	DADO	NUT	ECROU	MUTTER	TUERCA		1	
3	R60110041AY	BOCCOLA	BUSH	DOUILLE	BUCHSE	CASQUILLO		1	
4	R91350072B	DADO	NUT	ECROU	MUTTER	TUERCA		1	
5	R91350082B	DADO	NUT	ECROU	MUTTER	TUERCA		2	
6	R300957162000	PIASTRINO	PLATE	PLAQUETTE	PLÄTTCHEN	LÁMINA		1	
7	R93650029E	VITE	SCREW	VIS	SCHRAUBE	TORNILLO		3	
8	R300052007000	PERNO	PIN	PIVOT	ZAPFEN	PERNO		2	
9	R100279118000	GOMMINO ANTIVIBRANTE	VIBRATION DAMPER PAD	JOINT EN CAOUTCHOUC ANTI-VIBRATION	SCHWINGUNGSDÄMPFERGUMMI	JUNTA DE GOMA ANTI-VIBRACIÓN		4	
10	R90750532B	VITE	SCREW	VIS	SCHRAUBE	TORNILLO		1	
11	R30095007000X	TELAIETTO	FRAME	CADRE	RAHMEN	CHASSIS		1	
12	R90751292B	VITE	SCREW	VIS	SCHRAUBE	TORNILLO		2	
13	R300993048000	KIT ADESIVI	KIT STICKER	KIT DÉCALCOMANIE	KIT AUFKLEBER	KIT ADHESIVO	BLACK	1	
13	R301093078000	KIT ADESIVI	KIT STICKER	KIT DÉCALCOMANIE	KIT AUFKLEBER	KIT ADHESIVO	MY 2009 VERSION WHITE	1	

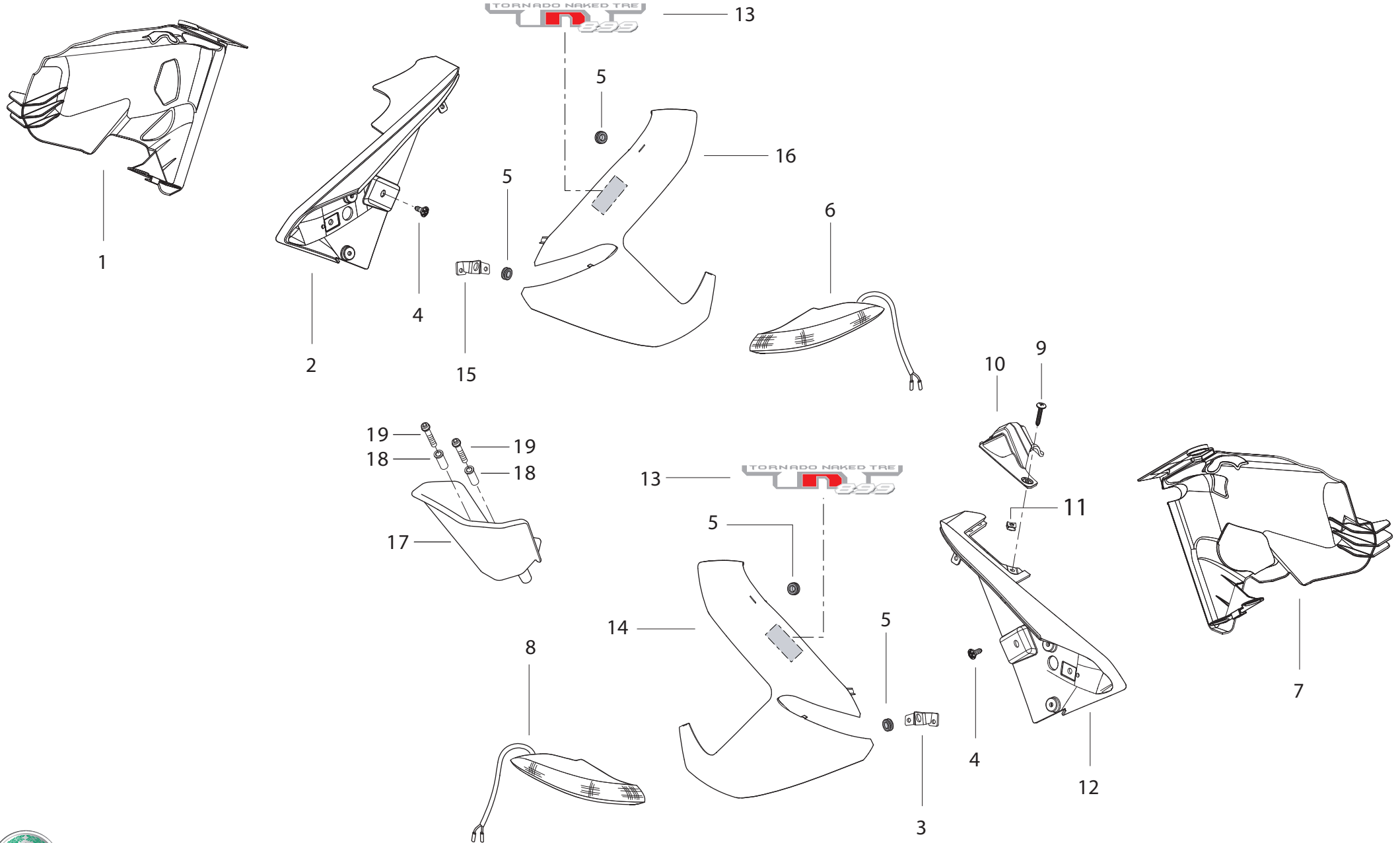

POS. NO. N. INDEX POS.	N. CODICE CODE NO. Nr. CODE ATRİKEL Nr. CODICO Nr.	DESCRIZIONE	DESCRIPTION	DESIGNATION	BEZEICHNUNG	DENOMINACION	NOTE NOTES MARKE NOTAS	Q.TA' Q.TY Q.TE M.GE C.AD	
1	R300084005000	CONVOGLIATORE ARIA SX	L.H.AIR MANIFOLD	CONVOYEUR D' AIR GAUCHE	LUFTFÖRDERER LINKER	ENCANALADOR AIRE IZQ.		1	
2	R3000741850CA	CARENATURA SUP INTERNA SX	L.H.INNER UPPER FAIRING	CARÉNAGE SUPÉRIEURE INTERNE GAUCHE	SCHALE OBERER INNERE LINKER	BASTIDOR SUPERIOR INTERIOR IZQ.		1	
3	R300074212000	STAFFA CONVOGLIATORE DX	R.H.BRACKET MANIFOLD	BRIDE CONVOYEUR DROIT	BÜGEL LUFTFÖRDERER RECHT	SOPORTE ENCANALADOR DER.		1	
4	R90752032B	VITE	SCREW	VIS	SCHRAUBE	TORNILLO		2	
5	R90752972B	VITE	SCREW	VIS	SCHRAUBE	TORNILLO		4	
6	R180278002000	LAMPEGGIATORE ANTERIORE SX	L.H.FRONT FLASHER	CLIGNOTEUR AVANT GAUCHE	FLUTLICHTLAMPE VORDERE LINKER	INTERMITENTE DELANTERA IZQ.		1	
7	R300084006000	CONVOGLIATORE ARIA DX	R.H.AIR MANIFOLD	CONVOYEUR D' AIR DROIT	LUFTFÖRDERER RECHT	ENCANALADOR AIRE DER.		1	
8	R180278001000	LAMPEGGIATORE ANTERIORE DX	R.H.FRONT FLASHER	CLIGNOTEUR AVANT DROITE	FLUTLICHTLAMPE VORDERE RECHT	INTERMITENTE DELANTERA DER.		1	
9	R93650019E	VITE	SCREW	VIS	SCHRAUBE	TORNILLO		1	
10	R3000742140CA	COPERCHIO TAPPO RADIATORE	RADIATOR CAP COVER	COUVERCLE BOUCHON RADIATEUR	DECKEL VERSCHLUß FÜR KÜLER	TAPA TAPÓN RADIADOR		1	
11	R95050052A	CLIP FISSAGGIO RAPIDO	QUIK FASTENING	FIXATION RAPIDE	SCHNELLEBFESTIGUNG	FIJACIÓN RÁPIDA		1	
12	R3000741840CA	CARENATURA SUPERIORE INTERNA DX	R.H.INNER UPPER FAIRING	CARÉNAGE SUPÉRIEURE INTERNE DROITE	SCHALE OBERER INNERE RECHT	BASTIDOR SUPERIOR INTERIOR DER.		1	
13	R300993001000	ADESIVO CARENE 899	FAIRINGS STIKER	DÉCALCOMANIE CARÈNE	AUFKLEBER BODEN	ADHESIVO CARENADO		2	
14	R3000741823CB	CARENATURA SUPERIORE ESTERNA DX NERA	R.H.BLACK OUTER UPPER FAIRING	CARÉNAGE SUPÉRIEURE EXTERNE NOIR DROITE	SCHALE OBERER ÄUßERE SCHWARZ RECHT	BASTIDOR SUPERIOR EXTERIOR NEGRO DER.		1	
14	R3000741822CU	CARENATURA SUPERIORE ESTERNA DX BIANCA	R.H.WHITE OUTER UPPER FAIRING	CARÉNAGE SUPÉRIEURE EXTERNE BLANC DROITE	SCHALE OBERER ÄUßERE WEIß RECHT	BASTIDOR SUPERIOR EXTERIOR BLANCO DER.		1	
15	R300074213000	STAFFA CONVOGLIATORE SX	L.H.BRACKET MANIFOLD	BRIDE CONVOYEUR GAUCHE	BÜGEL LUFTFÖRDERER LINKER	SOPORTE ENCANALADOR IZQ.		1	
16	R3000741833CB	CARENATURA SUPERIORE ESTERNA SX NERA	L.H.BLACK OUTER UPPER FAIRING	CARÉNAGE SUPÉRIEURE EXTERNE NOIR GAUCHE	SCHALE OBERER ÄUßERE SCHWARZ LINKER	BASTIDOR SUPERIOR EXTERIOR NEGRO IZQ.		1	
16	R3000741832CU	CARENATURA SUPERIORE ESTERNA SX BIANCA	L.H.WHITE OUTER UPPER FAIRING	CARÉNAGE SUPÉRIEURE EXTERNE BLANC GAUCHE	SCHALE OBERER ÄUßERE WEIß LINKER	BASTIDOR SUPERIOR EXTERIOR BLANCO IZQ.		1	
17	R300074191000	COPERCHIO BLOCCASTERZO	STEERING LOCK COVER	COUVERCLE BLOQUE DIRECTION	DECKEL LENKSPERRE	TAPA BLOQUE EMBRAGUE		1	
18	R300079184000	BOCCOLA	BUSH	DOUILLE	BUCHSE	CASQUILLO		2	
19	R90250272B	VITE	SCREW	VIS	SCHRAUBE	TORNILLO		2	

SERBATOIO



SERBATOIO



FUEL TANK



RÉSERVOIR CARBURANT



KRAFTSTOFFTANK



DEPÓSITO GASOLINA

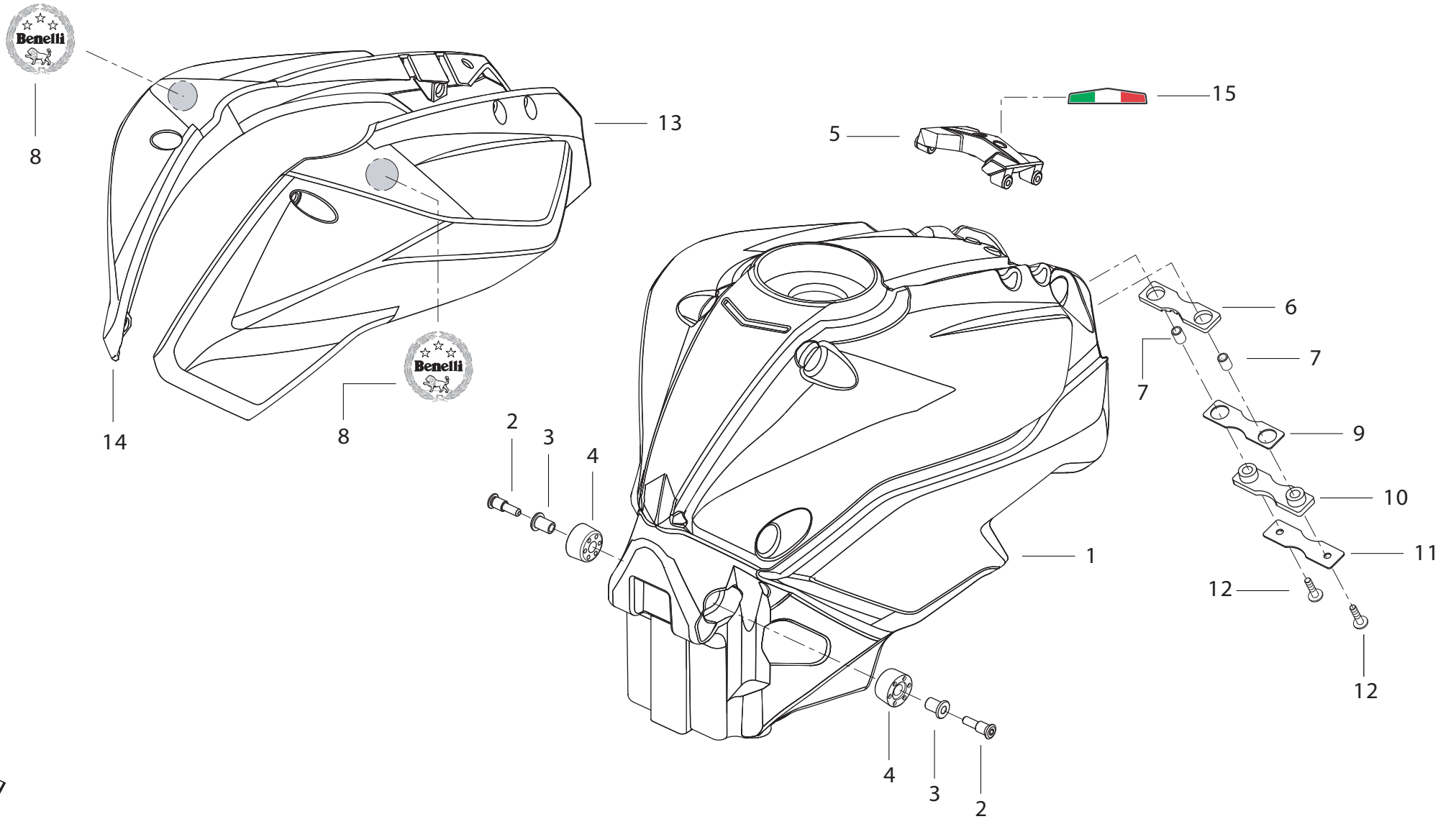

POS. NO. INDEX POS.	N. CODICE CODE NO. Nr. CODE ATRIKEL Nr. CODICO Nr.	DESCRIZIONE	DESCRIPTION	DESIGNATION	BEZEICHNUNG	DENOMINACION	NOTE NOTES NOTES MARKE NOTAS	Q.TA' Q.TY Q.TE M.GE C.AD	
1	R300088100000	SERBATOIO	FUEL TANK	RÉSEVOIR CARBURANT	KRAFTSTOFFTANK	DEPÓSITO GASOLINA		1	
2	R90752882B	VITE SPECIALE	SPECIAL SCREW	VIS SPÉCIALE	SPEZIALSCHRAUBE	TORNILLO ESPECIAL		2	
3	R300079182000	BOCCOLA	BUSH	DOUILLE	BUCHSE	CASQUILLO		2	
4	R300079181000	TAMPONE IN GOMMA	RUBBER PAD	TAMPON EN CAOUTCHOUC	GUMMISTOPFEN	APOYO DE GOMA		2	
5	R3000742090CF	CHIUSURA CALOTTE	CAPS CLOSING	FERMETURE CALOTTE	VERSCHLUß KAPPE	CIERRE CASQUETE		1	
6	R21814201A	GOMMINO SUPERIORE	UPPER RUBBER PAD	JOINT EN CAOUTCHOUC SUPÉRIEURE	OBERE GUMMISTÜCK	JUNTA DE GOMA SUPERIOR		1	
7	R21215501A	DISTANZIALE	SPACER	ENTRETOISE	DISTANZSTÜCK	DISTANCIAL		2	
8	R300093002000	ADESIVO CALOTTE	CAPS STIKER	DÉCALCOMANIE CALOTTE	AUFKLEBER KAPPE	ADHESIVO CASQUILLO		2	
9	R300057160000	PIASTRINO	PLATE	PLAQUETTE	PLÄTTCHEN	LÁMINA		1	
10	R21814211A	GOMMINO INFERIORE	LOWER RUBBER PAD	JOINT EN CAOUTCHOUC INFÉRIEURE	UNTER GUMMISTÜCK	JUNTA DE GOMA INFERIOR		1	
11	R21313761A	PIASTRINO	PLATE	PLAQUETTE	PLÄTTCHEN	LÁMINA		1	
12	R90752172B	VITE	SCREW	VIS	SCHRAUBE	TORNILLO		2	
13	R3000742082CB	CALOTTA SERBATOIO DX NERA	RIGHT BLACK FUEL TANK CAP	CALOTTE RÉSEVOIR CARBURANT DROITE NOIR	KAPPE KRAFTSTOFFTANK RECHTS SCHWARZ	CASQUETE DEPÓSITO GASOLINA DER.NEGRO		1	
13	R3000742080CU	CALOTTA SERBATOIO DX BIANCA	RIGHT WHITE FUEL TANK CAP	CALOTTE RÉSEVOIR CARBURANT DROITE BLANC	KAPPE KRAFTSTOFFTANK RECHTS WEIß	CASQUETE DEPÓSITO GASOLINA DER.BLANCO		1	
14	R3000742072CB	CALOTTA SERBATOIO SX NERA	LEFT BLACK FUEL TANK CAP	CALOTTE RÉSEVOIR CARBURANT GAUCHE NOIR	KAPPE KRAFTSTOFFTANK LINKS SCHWARZ	CASQUETE DEPÓSITO GASOLINA DER.NEGRO		1	
14	R3000742070CU	CALOTTA SERBATOIO SX BIANCA	LEFT WHITE FUEL TANK CAP	CALOTTE RÉSEVOIR CARBURANT GAUCHE BLANC	KAPPE KRAFTSTOFFTANK LINKS WEIß	CASQUETE DEPÓSITO GASOLINA DER.BLANCO		1	
15	R300093100001	ADESIVO	STIKER	DÉCALCOMANIE	AUFKLEBER	ADHESIVO		1	

SERRATURE

 SERRATURE

 LOCKS

 SERRURE

 SCHLOß

 CERRADURES

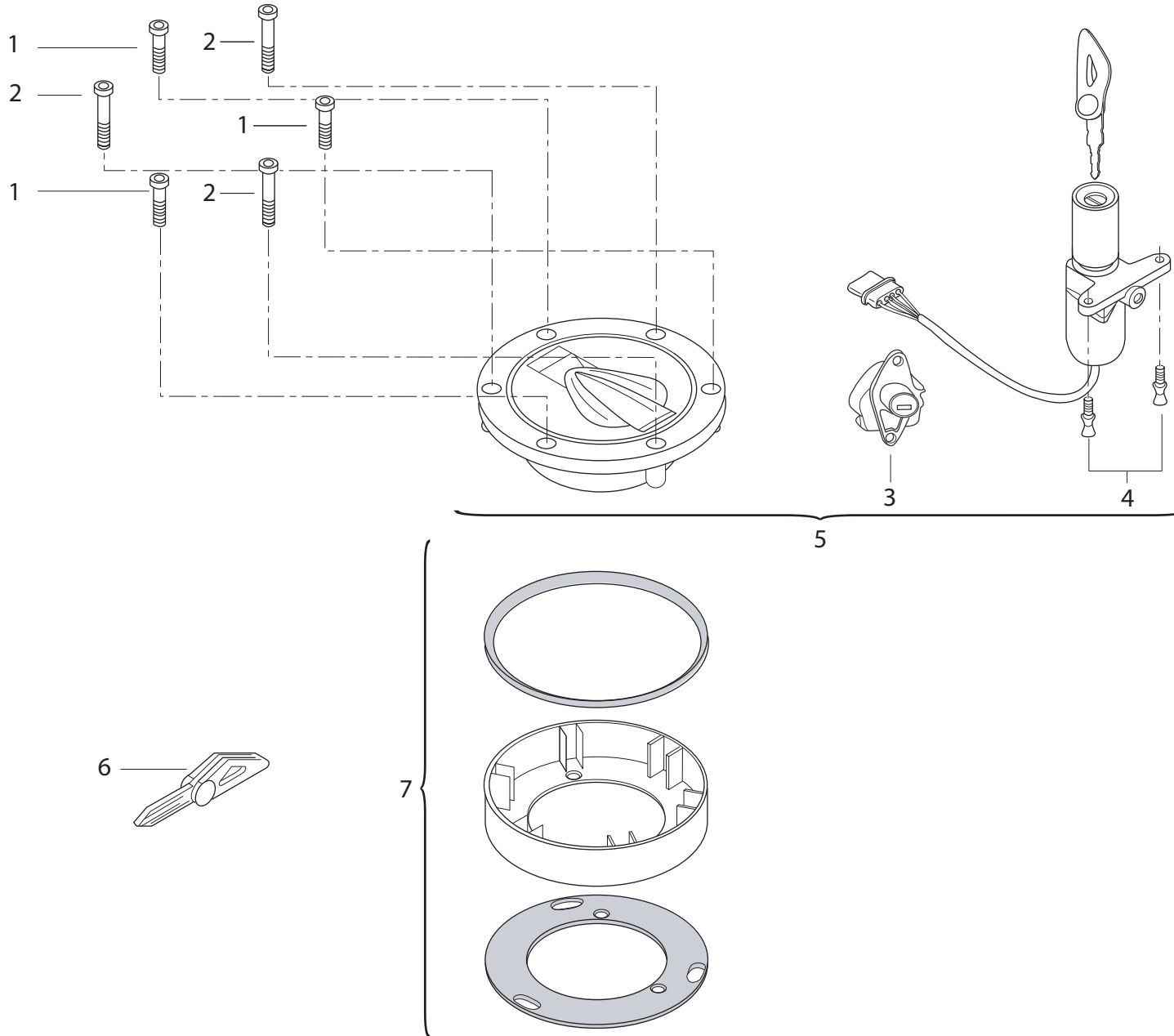

POS. NO. N. INDEX POS.	N. CODICE CODE NO. Nr. CODE ATRIKEL Nr. CODICO Nr.	DESCRIZIONE	DESCRIPTION	DESIGNATION	BEZEICHNUNG	DENOMINACION	NOTE NOTES MARKE NOTAS	Q.TA' Q.TY Q.TE M.GE C.AD	
1	R90250478E	VITE	SCREW	VIS	SCHRAUBE	TORNILLO		3	
2	R90250408E	VITE	SCREW	VIS	SCHRAUBE	TORNILLO		3	
3	R180266126000	SERRATURA SELLA	SEAT LOCK	SERRURE SELLE	SATTELSCHLOß	CERRADURA SILLÍN		1	
4	R180166008000	VITE	SCREW	VIS	SCHRAUBE	TORNILLO		2	
5	R300066002000	GRUPPO SERRATURE	LOCKS KIT	JEU SERRURE	SCHLOßGRUPPE	GRUPO CERRADURAS		1	
6	R180266128000	CHIAVE	WRENCH	CLÈ	SCHLUSSEL	LLAVE		1	
7	R180166125000	GUARNIZIONE	GASKET	GARNITURE	DICHTUNG	JUNTA		1	

PARAFANGO POSTERIORE

PARAFANGO POSTERIORE

REAR MUDGUARD

GARDE-BOUE ARRIÈRE

HINTERE SCHUTZBLECH

GUARDABARROS TRASERO

TAVOLA
DRAWING
TABLE
BILD
TABLA

044

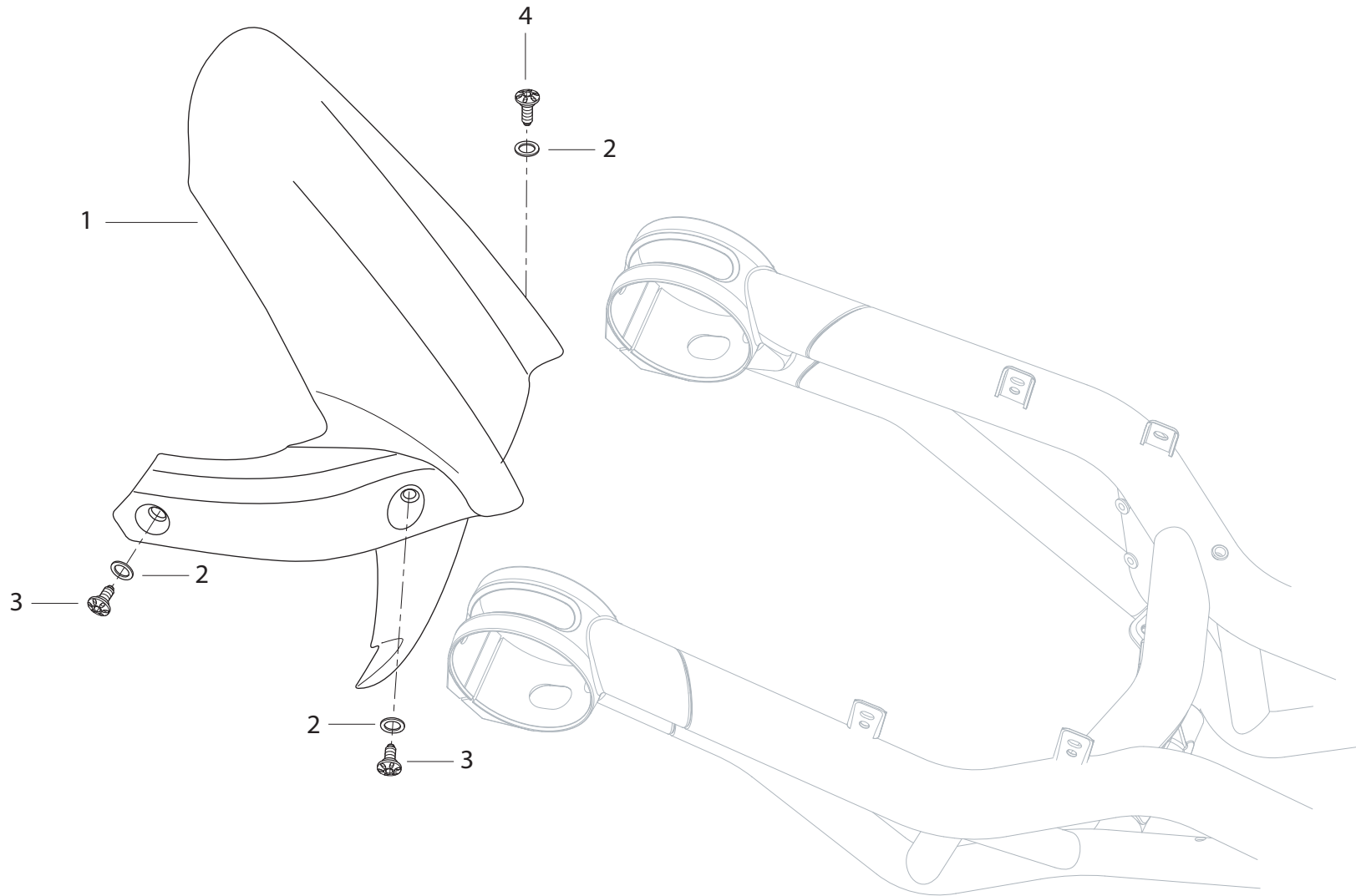

POS. NO. N. INDEX POS.	N. CODICE CODE NO. Nr. CODE ATRIKEL Nr. CODICO Nr.	DESCRIZIONE	DESCRIPTION	DESIGNATION	BEZEICHNUNG	DENOMINACION	NOTE NOTES MARKE NOTAS	Q.TA' Q.TY Q.TE M.GE C.AD	
1	R3000741710CB	PARAFANGO POSTERIORE	REAR MUDGUARD	GARDE-BOUE ARRIÈRE	HINTERE SCHUTZBLECH	GUARDABARROS TRASERO		1	
1	R3000741710CU	PARAFANGO POSTERIORE BIANCO	WHITE REAR MUDGUARD	GARDE-BOUE ARRIÈRE BLANC	HINTERE SCHUTZBLECH WEIB	GUARDABARROS TRASERO BLANCO		1	
2	R90752302B	RONDELLA	WASHER	RONDELLE	UNTERLEGSSCHEIBE	ARANDELA		3	
3	R90752268E	VITE	SCREW	VIS	SCHRAUBE	TORNILLO		2	
4	R90750708E	VITE	SCREW	VIS	SCHRAUBE	TORNILLO		1	



IL PRESENTE MANUALE È PROPRIETÀ DELLA
BENELLI Q.J. S.R.L.
OGNI PRODUZIONE, TOTALE O PARZIALE,
È VIETATA.

THIS MANUAL IS PROPERTY OF
BENELLI Q.J. S.R.L.
ANY TOTAL OR PARTIAL REPRODUCTION
IS FORBIDDEN.

CE MANUEL EST DE LA PROPRIÉTÉ DE
BENELLI Q.J. S.R.L.
TOURE REPRODUCTION TOTALE OU
PARTIELLE, ESTINTERDITE.

DIE VORLIEGENDE BEDIENUNGSANLEITUNG
STEHT IM EIGENTUM VON BENELLI Q.J. S.R.L.
JEDE VÖLLIGE ODERTEILWEISE KOPIE
IST VERBOTEN.

EL PRESENTE MANUAL ES PROPIEDAD
DE BENELLI Q.J. S.R.L.
SE PROHÍBE SU REPRODUCCIÓN
TOTAL O PARCIAL.



Benelli consiglia accessori originali
Benelli suggestions original accessories
Benelli conseiller accessoires original
Benelli raten Zubehör originell
Benelli aconsejar accesorios originales



Ver. 03 - Apr. 09
Benelli Q.J. s.r.l.
Strada della Fornace Vecchia
61100 - Pesaro - Italy
www.benelli.com