

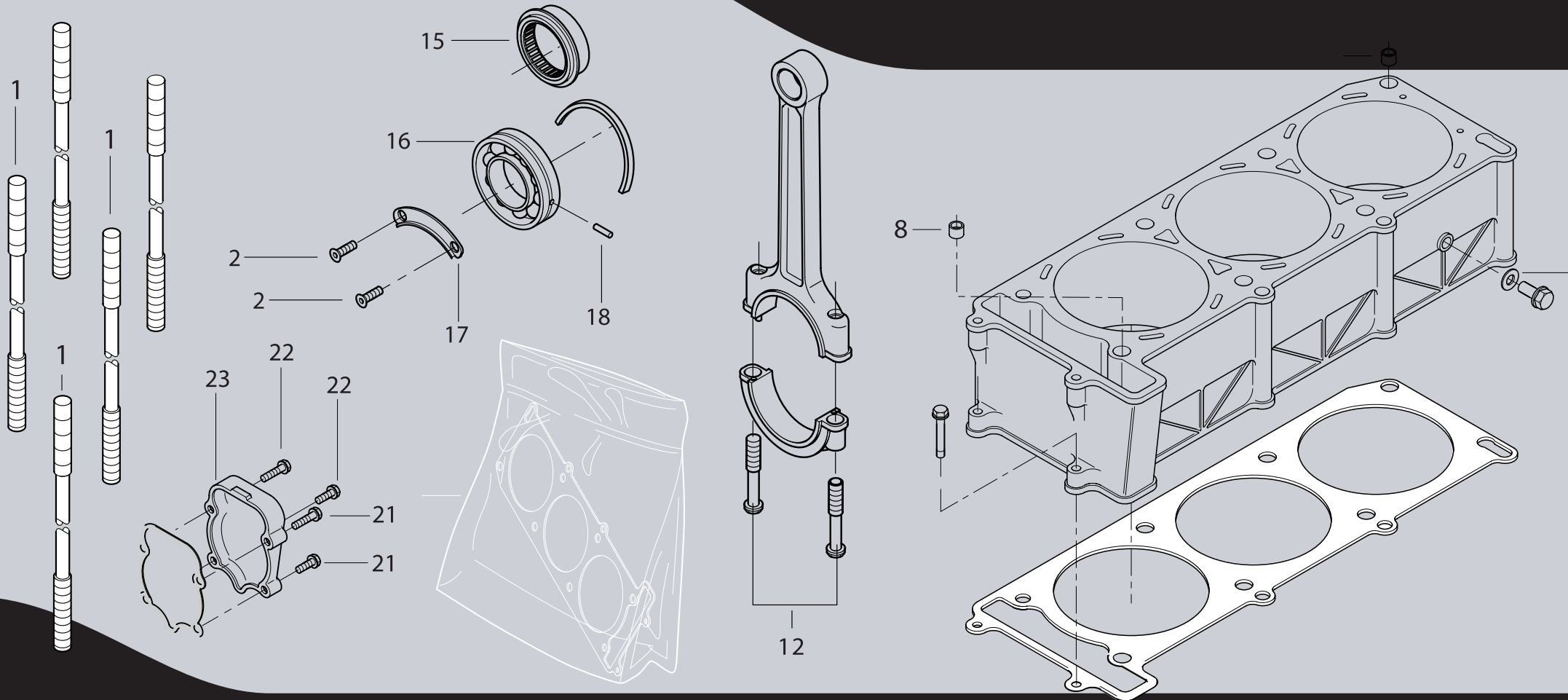

Pure Passion since 1911

TREK 1130



CATALOGO RICAMBI • SPARE PARTS CATALOGUE • CATALOGUE PIÉCES DETACHEES
ERSATZTEILKATALOG • CATALO PIEZAS DE REPUESTO

QUESTO CATALOGO SERVE PER RICHIEDERE CON ESATTEZZA LE PARTI DI RICAMBIO.

NELLE ORDINAZIONI INDICARE: IL NUMERO DEI CODICI DEI PARTICOLARI SEGUITO DALLA DESCRIZIONE E LA QUANTITÀ DESIDERATA.

LE INDICAZIONI CON LE FRECCIE SI RIFERISCONO AI LATI DEL VEICOLO RISPETTO AL SENSO DI MARCIA.

I DISEGNI DELLE PARTI DI RICAMBIO SONO SOLO INDICATIVI E NON RAPPRESENTANO IL PEZZO IN OGGETTO.

I DATI CONTENUTI IN QUESTO CATALOGO SONO INDICATIVI E POSSONO ESSERE SOGGETTI A MODIFICHE SENZA IMPEGNO DI PREAVVISO.

THE PRESENT SPARE PARTS ORDER EXACTLY THE RIGHT SPARE PARTS.

WHEN ORDERING SPECIFY: THE PART'S CODE NUMBER FOLLOWED BY ITS DESCRIPTION AND QUANTITY NEEDED.

REFERENCE WITH ARROWS APPLY TO THE VEHICLE IN TERMS OF ITS DIRECTION OF MOVEMENT.

SPARE PARTS DRAWINGS ARE GENERAL AND DO NOT REPRESENT THE PART.

THE CONTENTS OF THIS CATALOGUE ARE GENERAL AND CAN UNDERGO CHANGES WITHOUT PRIOR NOTICE.

CE CATALOGUE PERMET DE COMMANDER CORRECTEMENTE LES PIÈCES DÉTACHÉES.

LES COMMANDES DOIVENT ÊTRE PASSÉES EN INDIQUANT: LE NUMERO DE CODE DES PIÈCES DÉTACHÉES SUIVI DE LEUR DESCRIPTION ET QUANTITÉ DÉSIRÉE.

RÉFÉRENCE AVEC DES FLÈCHES SONT LES CÔTÉS DU VÉHICULE PAR RAPPORT AU SENS DE LA MARCHÉ.

LES PLANS DES PIÈCES DÉTACHÉES SONT FOURNIS SEULEMENT À TITRE INDICATIF ET NE REPRÉSENTENT PAS LA PIÈCE CONCERNÉE.

LES DONNÉES DE CE CATALOGUE SONT CITÉES SEULEMENT À TITRE INDICATIF ET PEUVENT ÊTRE L'OBJET DE MODIFICATIONS SANS AVIS PRÉALABLE.

DIESER ERSATZTEILKATALOG DIEN ZUR GENAUEN ANGABE DER TEILE BEI ERSATZTEILBESTELLUNGEN.

BEIERSATZBESTELLUNG IST FOLGENDES ANZUGEBEN: DIE BESTELLNUMMER DER ERSATZTEILE MIT DER ENTSPRECHENDEN BESCHREIBUNG UND GENAUEN MENGE.

DIE ANGABEN MIT PFEILE BEZIEHEN SICH AUF DAS FAHRZEUG IN FAHRRICHTUNG.

DIE ZEICHNUNGEN DER ERSATZTEILE SIND NUR ALS HINWEISE GEDACHT UND STELLEN NICHT DAS BETROFFENE TEIL DAR.

BEI DEN IM KATALOG ANGEFÜHRTEN DATEN HANDELT ES SICH UM ANHALTSDATEN, DIE JEDERZEIT, OHNE VORANKÜNDIGUNG, GEÄNDERT WERDEN KÖNNEN.

EL PRESENTE CATÁLOGO SIRVE PARA PEDIR CON EXACTITUD LAS PARTES DE REPUESTO.

EN LOS PEDIDOS SE DEBE INDICAR: EL NÚMERO DE CÓDIGO DE LA PARTE Y A CONTINUACIÓN LA DESCRIPCIÓN Y CANTIDAD DESEADA.

LAS INDICACIONES CON LAS FLECHAS SE REFIEREN A LOS LADOS DEL VEHÍCULO RESPECTO DEL SENTIDO DE MARCHA.

LOS DISEÑOS DE LAS PARTES DE RECAMBIO SON SOLO INDICATIVOS Y NO REPRESENTAN LA PIEZA EN CUESTIÓN.

LOS DATOS CONTENIDOS EN EL PRESENTE CATÁLOGO SON INDICATIVOS Y PUEDEN MODIFICARSE SIN AVISO PREVIO.

3	00A	ATTREZZI SPECIALI	SPECIAL TOOLS	OUTILS SPECIAUX	SONDERWERKZEUGE	HERRAMENTAL ESPECIALES
5	001	DISTRIBUZIONE	TIMING	DISTRIBUTION	VENTILSTEUERUNG	DISTRIBUCIÓN
9	002	GRUPPO TESTA	CYLINDER HEAD	GROUPE CULASSE	ZYLINDERKOPFGRUPPE	GRUPO CULATA
15	003	CILINDRO PISTONI	CYLINDER PISTONS	CYLINDRE PISTONS	ZYLINDER KOLBEN	CILINDRO PISTONES
17	004	ASSIEME MANOVELLISMO	CRANK GEAR ASSEMBLY	ENSEMBLE BIELLISME	KURBELGETRIEBE KOMPLETT	JUNTO CINEMATISMO
19	005	COPPIA SEMICARTER	HALF CRANKCASES	DEMI-CARTERS	GEHÄUSEHÄLFTE	PAREJA SEMI-CARTER
21	006	ASSIEME CARTER	GUARD ASSEMBLY	ESEMBLE CARTERS	GEHÄUSE KOMPLETT	GRUPO CARTER
25	007	COPERCHI MOTORE	ENGINE COVERS	COUVERCLES MOTEUR	MOTOR DECKEL	TAPAS MOTOR
29	008	LUBRIFICAZIONE	LUBRIFICATION	LUBRIFICATION	SCHMERUNG	LUBRICACIÓN
31	009	POMPA ACQUA	WATER PUMP	POMPE EAU	WASSERPUMPE	BOMBA AGUA
35	010	FRIZIONE	CLUTCH	EMBAYAGE	KUPPLUNG	EMBRAGUE
39	011	COMANDO CAMBIO	GEARCHANGE	COMMANDE BOÎTE A VITESSES	GANGSCHALTUNG	MANDO CAMBIO
43	012	CAMBIO	GEAR-BOX	BOÎTE A VITESSES	SCHALTUNG	CAMBIO
47	013	RADIATORE ACQUA	WATER RADIATOR	RADIATEUR D'EAU	WASSERKUEHLER	RADIATOR AGUA
49	014	CIRCUITO DI RAFFREDDAMENTO	COOLING CIRCUIT	CIRCUIT DE REFROIDISSEMENT	KÜHLREISLAUF	CIRCUITO DE REFRIGERADOR
51	015	ALIMENTAZIONE	FEEDING	ALIMENTACION	VERSORGUNG	ALIMENTACIÓN
53	016	ASPIRAZIONE	INTAKE	ASPIRATION	LUFTEINZUG	ASPIRACIÓN
57	017	GRUPPO SCARICO	EXHAUST SYSTEM	ECHAPPEMENT	AUSPUFFANLAGE	GRUPO ESCAPE
61	018	IMPIANTO ELETTRICO	ELECTRIC SYSTEM	INSTALLATION ELECTRIQUE	ELEKTRISCHE ANLAGE	SISTEMA ELECTRICO
63	019	AVVIAMENTO ELETTRICO	ELECTRIC STARTER	DEMARRAGE ELECTRONIQUE	ELEKTROSTARTER ANLASSER	PUESTA EN MARCHA ELECTRICA
67	020	STRUMENTAZIONE	INSTRUMENTATION	INSTRUMENTATION	INSTRUMENTEN-AUSRÜSTUNG	INSTRUMENTACIÓN
69	021	SENSORI	SENSORS	CAPTEURS	SENSOR	SENSORS
71	022	FANALI	HEAD-LIGHTS	PHARES	SCHEINWERFERS	FAROS
73	023	TELAIO	FRAME	CADRE	RAHMEN	CHASIS
75	024	CAVALLETTO	STAND	BEQUILLE	BOCK	CABALLETTE
77	025	FORCELLONE	SWINGARM	FOURCHE	SCHWINGE	BASCULANTE
79	026	ASSIEME FORCELLONE	SWING ARM ASSEMBLY	ENSEMBLE FOURCHE	GABEL KOMPLETT	GRUPO BASCULANTE
81	027	SOSPENSIONE POSTERIORE	REAR SUSPENSION	SUSPENSION ARRIÈRE	HINTERRADFEDERUNG	SUSPENSION TRASERA
83	028	CODONE	TAIL GUARD	CORPS DE SELLE	HECK	CUERPO ASIENTO
85	029	SCATOLA BATTERIA	BATTERY BOX	BOÎTE BATTERIE	BATTERIEGEHÄUSE	CAJA BATERÍA
87	030	PORTATARGA	NUMBER PLATE HOLDER	PORTE-PLAQUE	NUMMERSCHILDTAFEL	PORTA-MATRÍCULA
89	031	PEDANE ANTERIORI	FRONT FOOT PEG	REPOSE PIEDS AVANT	VORDERE FUSSRASTE	ESTRIBERAS DELANTERA
93	032	PEDANE POSTERIORI	REAR FOOT PEG	REPOSE PIEDS ARRIÈRE	HINTERE FUSSRASTE	ESTRIBERAS TRASERA
95	033	PARAFANGO ANTERIORE	FRONT MUDGUARD	GARDE-BOUE AVANT	VORDERES SCHUTZBLECH	GUARDABARROS DELANTERO
97	034	FORCELLA ANTERIORE	FRONT FORK	FOURCHE AVANT	TELEGABEL	HORQUILLA DELANTERA
99	035	MANUBRIO E COMANDI	HANDLEBAR AND CONTROLS	GUIDON ET COMANDES	LENKER UND STEUERORGANE	MANILLAR Y MANDOS
101	036	FRENO ANTERIORE	FRONT BRAKE	FREIN AVANT	VORD BREMSE	FRENO DELANTERO
103	037	FRENO POSTERIORE	REAR BRAKE	FREIN ARRIÈRE	HINTERBREMSE	FRENO TRASERO
105	038	RUOTA ANTERIORE	FRONT WHELL	ROUE AVANT	VORDERRAD	RUEDA DELANTERA
107	039	RUOTA POSTERIORE	REAR WHEEL	ROUE ARRIÈRE	HINTERRAD	RUEDA TRASERA
109	040	CUPOLINO	HEADLIGHT FAIRING	CARÉNAGE	FAHRTWINDSCHUTZ	CÚPULA
111	041	CARENATURA	FAIRING	CARÉNAGE	SCHALE	BASTIDOR
113	042	SERBATOIO	FUEL TANK	RÉSEVOIR CARBURANT	KRAFTSTOFFTANK	DEPÓSITO GASOLINA
115	043	SERRATURE	LOCKS	SERRURE	SCHLOß	CERRADURES
117	044	PROTEZIONE MOTORE	ENGINE PROTECTION	PROTECTION MOTEUR	SCHUTZ MOTOR	PROTECCIÓN MOTOR
119	045	PARAFANGO POSTERIORE	REAR MUDGUARD	GARDE-BOUE ARRIÈRE	HINTERE SCHUTZBLECH	GUARDABARROS TRASERO

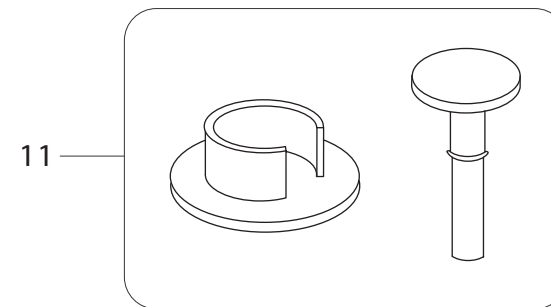
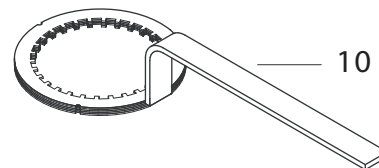
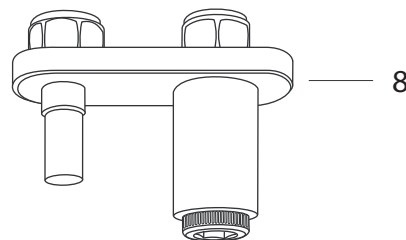
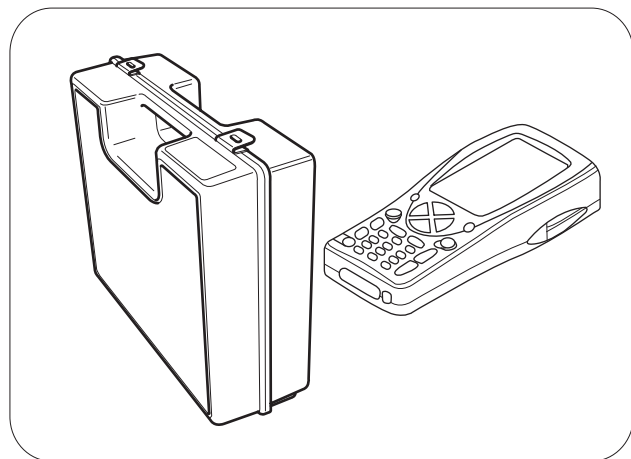
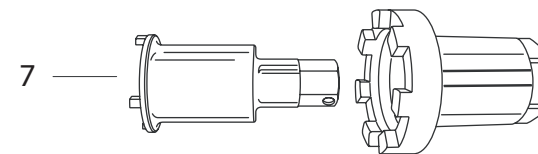
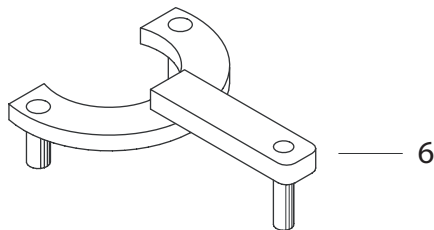
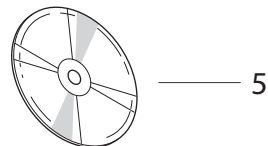
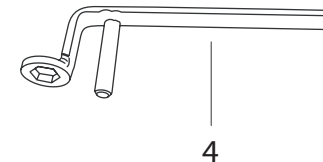
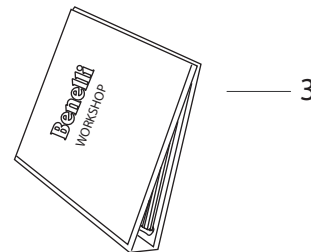
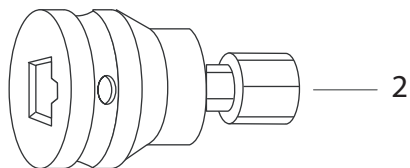
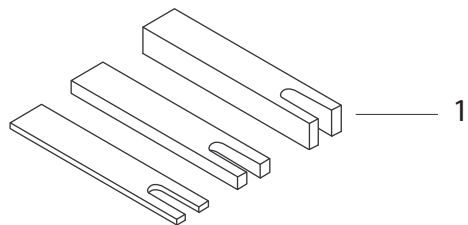



POS. NO. N. INDEX POS.	N. CODICE CODE NO. Nr. CODE ATRIKEL Nr. CODICO Nr.	DESCRIZIONE	DESCRIPTION	DESIGNATION	BEZEICHNUNG	DENOMINACION	NOTE NOTES NOTES MARKE NOTAS	Q.TA' Q.TY Q.TE M.GE C.AD	
1	R180197018000	DISTANZIALE MONTAGGIO CILINDRO	SPACER TO ASSEMBLY CYLINDER	ENTRETOISE AU CYLINDRE D'ASSEMBLÉE	DISTANZSTÜCK ZUM VERSAMMLUNG ZYLINDER	DISTANCIAL DEL CILINDRO		1	
2	R300097146000	CHIAVE MONTAGGIO TESTA DI STERZO	WRENCH MOUNTING STEERING HEAD	CLÉ DE TÊTE DE DIRECTION	SCHLÜSSEL FÜR MONTAGE GABELKOPF	LLAVE DEL MONTAJE DE LA TIJA SUPERIOR		1	
3	R310094100000	MANUALE OFFICINA	WORKSHOP MANUAL	CMANUEL D'ATELIER	TECHNISCHES HANDBUCH	MANUAL TALLER		1	
4	R180297130000	CHIAVE REGOLAZIONE SPINGIDISCO	WRENCH REGULATION PRESSURE PLATE	CLÉ DE POUSSÉ-DISQUE RÉGLEMENTAIRE	SCHLÜSSEL REGELUNG SCHEIBENDRÜCKER	LLAVE DE LA REGLA PLACA DE PRESIÓN		1	
5	R310094104000	MANUALE UTENTE	OWNER'S MANUAL	MANUEL UTILISATEUR	BENUTZER HANDBUCH	MANUAL USUARIO		1	
6	R180297048000	CHIAVE MONTAGGIO PIGNONE	WRENCH MOUNTING SPROCKET	CLÉ DE TÊTE DE PIGNON	SCHLÜSSEL FÜR MONTAGE RITZEL	LLAVE DEL MONTAJE DEL PIÑÓN		1	
7	R180297129000	CHIAVE MONTAGGIO GHIERA DI STERZO	WRENCH MOUNTING STEERING RING NUT	CLÉ DE TÊTE DE BAGUE DE DIRECTION	SCHLÜSSEL FÜR MONTAGE LENKUNGSZAPFEN	LLAVE DEL MONTAJE DEL ZUNCHO DE DIRECCIÓN		1	
8	R300097147000	CHIAVE TENSIONAMENTO CATENA TRASMISSIONE	WRENCH FOR TENSIONING TRANSMISSION CHAIN	CLÉ DE MISE EN TENSION CHAÎNE DE TRANSMISSION	SCHLÜSSEL FÜR SPANNGETRIEBE-KETTE	LLAVE PARA LA CADENA TENSORA DE LA TRANSMISIÓN		1	
9	R180197036000	STRUMENTO DIAGNOSI (IT)	DIAGNOSIS INSTRUMENT (IT)	INSTRUMENT DE DIAGNOSTIC (IT)	DIAGNOSE INSTRUMENT (IT)	INSTRUMENTO DE LA DIAGNOSIS (IT)		1	
9	R1801970360UK	STRUMENTO DIAGNOSI (UK)	DIAGNOSIS INSTRUMENT (UK)	INSTRUMENT DE DIAGNOSTIC (UK)	DIAGNOSE INSTRUMENT (UK)	INSTRUMENTO DE LA DIAGNOSIS (UK)		1	
9	R18019703600F	STRUMENTO DIAGNOSI (F)	DIAGNOSIS INSTRUMENT (F)	INSTRUMENT DE DIAGNOSTIC (F)	DIAGNOSE INSTRUMENT (F)	INSTRUMENTO DE LA DIAGNOSIS (F)		1	
9	R18019703600D	STRUMENTO DIAGNOSI (D)	DIAGNOSIS INSTRUMENT (D)	INSTRUMENT DE DIAGNOSTIC (D)	DIAGNOSE INSTRUMENT (D)	INSTRUMENTO DE LA DIAGNOSIS (D)		1	
9	R18019703600E	STRUMENTO DIAGNOSI (E)	DIAGNOSIS INSTRUMENT (E)	INSTRUMENT DE DIAGNOSTIC (E)	DIAGNOSE INSTRUMENT (E)	INSTRUMENTO DE LA DIAGNOSIS (E)		1	
10	R180297047000	CHIAVE FERMA CAMPANA TAMBURO FRIZIONE	WRENCH TO HOLD CLUCH HOUSING DRUM STEADY	CLÉ DE MANTEN TAMBOUR CLOCHE D'EMBTAYAGE	KUPPLUNGSGLOCKENSCHLÜSSEL	LLAVE SUJETA-TAMBOR CAJA EMBRAGUE		1	
11	R180100143000	KIT SGANCIO RAPIDOI	KIT RAPID REMOVE	KIT RAPIDE ENLEVER	KIT SCHNELL ENTFERNEN	KIT RÁPIDO QUITAR		1	

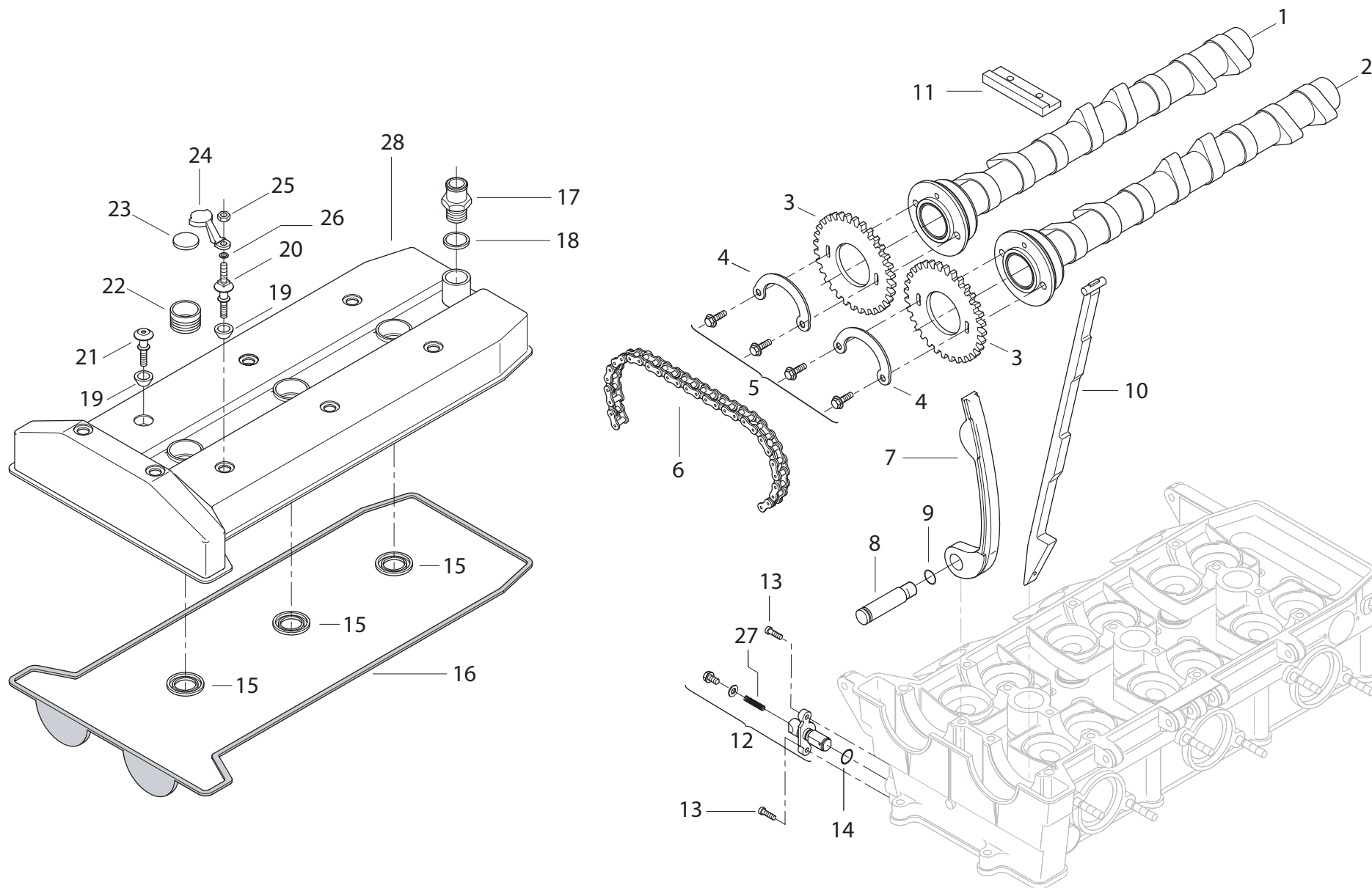

POS. NO. N. INDEX POS.	N. CODICE CODE NO. Nr. CODE ATRIKEL Nr. CODICO Nr.	DESCRIZIONE	DESCRIPTION	DESIGNATION	BEZEICHNUNG	DENOMINACION	NOTE NOTES NOTES MARKE NOTAS	Q.TA' Q.TY Q.TE M.GE C.AD	
1	R310017001000	ALBERO DISTRIBUZIONE ASPIRAZIONE	INTAKE CAMSHAFT	ARBRE DISTRIBUTION ASPIRATION	VERTEILERWELLE DER ANSAUGUNG	ARBOL DISTRIBUCIÓN ASPIRACIÓN		1	
2	R310017002000	ALBERO DISTRIBUZIONE SCARICO	EXHAUST CAMSHAFT	ARBRE DISTRIBUTION ÉCHAPPEMENT	VERTEILERWELLE AUSLAß	ARBOL DISTRIBUCIÓN DESCARGA		1	
3	R180217011000	INGRANAGGIO Z 34	GEAR Z 34	ENGRENAGE Z 34	ZAHNRAD Z 34	ENGRANAJE Z 34		2	
4	R180217012000	PIASTRINO SPECIALE	SPECIAL PLATE	PLAQUETTE SPÉCIALE	SPEZIALPLÄTTCHEN	LÁMINA ESPECIAL		2	
5	R15113281A	VITE	SCREW	VIS	SCHRAUBE	TORNILLO		4	
6	R15243031A	CATENA DISTRIBUZIONE	CHAIN DISTRIBUTION	DISTRIBUTION À CHAÎNE	KETTENVERTEILUNG	DISTRIBUCIÓN DE CADENA		1	
7	R15313141A	PATTINO CATENA	CHAIN SLIDER	PATIN CHAÎNE	KETTENGLEITSCHUH	PATÍN CADENA		1	
8	R15313201A	PERNO	PIN	PIVOT	ZAPFEN	PERNO		1	
9	R92850079M	ANELLO ELASTICO	SNAP RING	BAGUE ELASTIQUE	SPRENGRING	SEAGER		1	
10	R15313031A	PATTINO CATENA INFERIORE	LOWER CHAIN SLIDING SHOE	PATIN CHAÎNE INFÉRIEURE	UNTERER KETTENGLEITSCHUH	PATÍN CADENA INFERIOR		1	
11	R15313061A	PATTINO CATENA SUPERIORE	UPPER CHAIN SLIDING SHOE	PATIN CHAÎNE SUPÉRIEURE	OBERER KETTENGLEITSCHUH	PATÍN CADENA SUPERIOR		1	
12	R15343101A	TENDICATENA	CHAIN TENSIONER	TENDEUR DE CHAÎNE	KETTENSANNER	ENSOR DE CADENA		1	
13	R90750522B	VITE	SCREW	VIS	SCHRAUBE	TORNILLO		2	
14	R92850089M	GUARNIZIONE OR	O-RING	JOINT D'ÉTANCHÉITÉ	DICHTUNG OR	JUNTA OR		1	
15	R15513021A	GUARNIZIONE	GASKET	GARNITURE	DICHTUNG	JUNTA		3	
16	R15513011A	GUARNIZIONE COPERCHIO	COVER GASKET	GARNITURE COUVERCLE	DECKELDICHTUNG	JUNTA TAPA		1	
17	R180107002000	RACCORDO RAPIDO	QUICK-COUPLING UNION	RACCORD RAPIDE	STECKANSCHLUß	CONEXIÓN RÁPIDA		1	
18	R11043511A	ANELLO DI TENUTA	SEAL RING	BAGUE D'ÉTANCHÉITÉ	DICHTRING	ANILLO DE RETÉN		1	
19	R15513041A	GOMMINO	RUBBER PAD	JOINT EN CAOUTCHOUC	GUMMISTÜCK	JUNTA DE GOMA		2	
20	R15513061A	VITE SPECIALE	SPECIAL SCREW	VIS SPÉCIALE	SPEZIALSCHRAUBE	TORNILLO ESPECIAL		1	
21	R15513031A	VITE SPECIALE	SPECIAL SCREW	VIS SPÉCIALE	SPEZIALSCHRAUBE	TORNILLO ESPECIAL		1	
22	R18213241A	GOMMINO	RUBBER PAD	JOINT EN CAOUTCHOUC	GUMMISTÜCK	JUNTA DE GOMA		1	
23	R180133001000	GOMMINO	RUBBER PAD	JOINT EN CAOUTCHOUC	GUMMISTÜCK	JUNTA DE GOMA		1	
24	R180233002000	STAFFA	BRACKET	BRIDE	BÜGEL	SOPORTE		1	

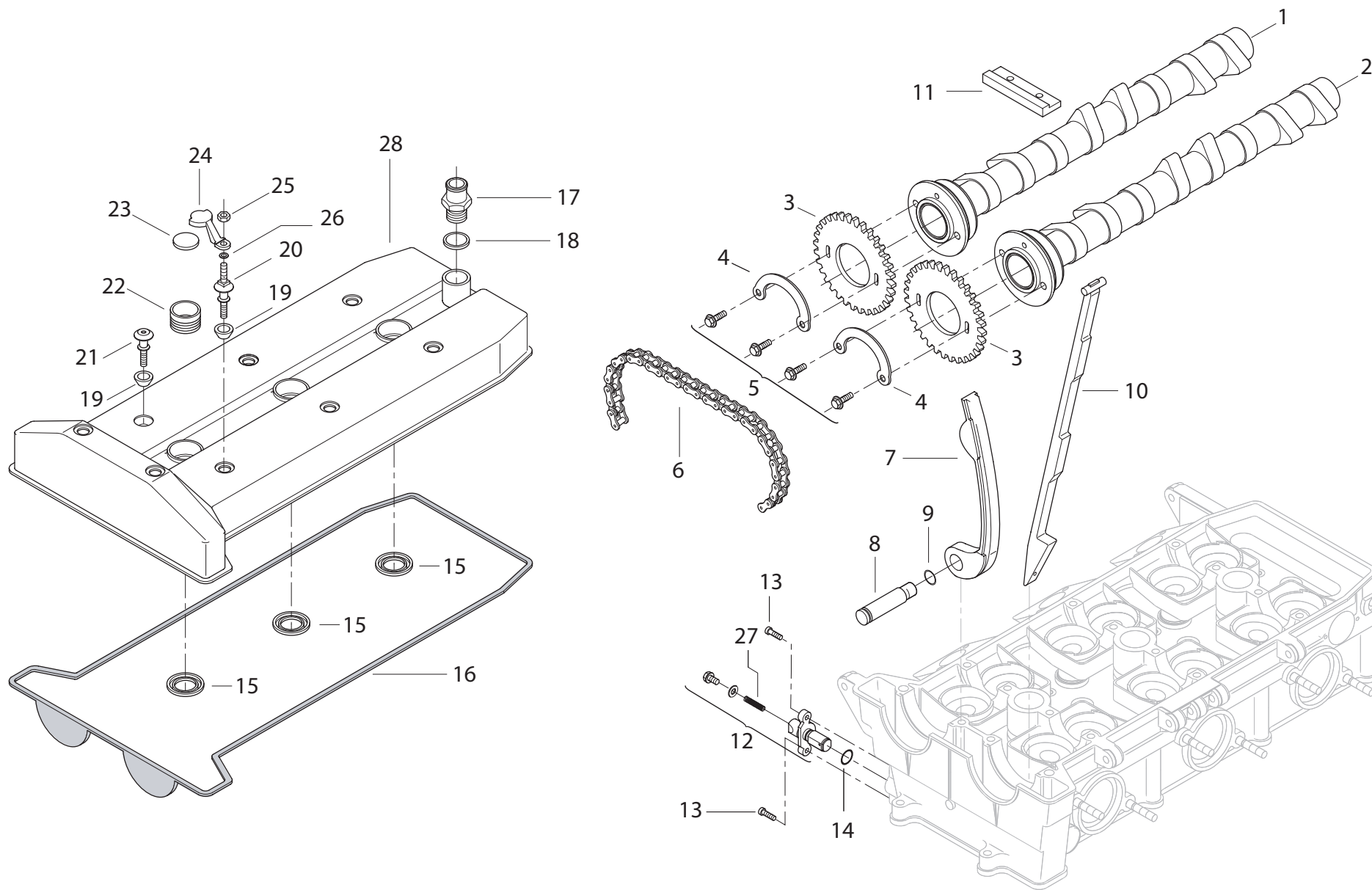

POS. NO. N. INDEX POS.	N. CODICE CODE NO. Nr. CODE ATRIKEL Nr. CODICO Nr.	DESCRIZIONE	DESCRIPTION	DESIGNATION	BEZEICHNUNG	DENOMINACION	NOTE NOTES NOTES MARKE NOTAS	Q.TA' Q.TY Q.TE M.GE C.AD	
25	R18243281A	DADO	NUT	ECROU	MUTTER	TUERCA		1	
26	R92751632B	RONDELLA	WASHER	RONDELLE	UNTERLEGSCHIEBE	ARANDELA		1	
27	R300018005000	MOLLA	SPRING	RESSORT	FEDER	MUELLE		1	
28	R1802010060CE	COPERCHIO DISTRIBUZIONE	CAMSHAFT COVER	COUVERCLE D'ARBRE Á CAMES	DECKELVERTEILER	CADENA DISTRIBUCIÓN		1	

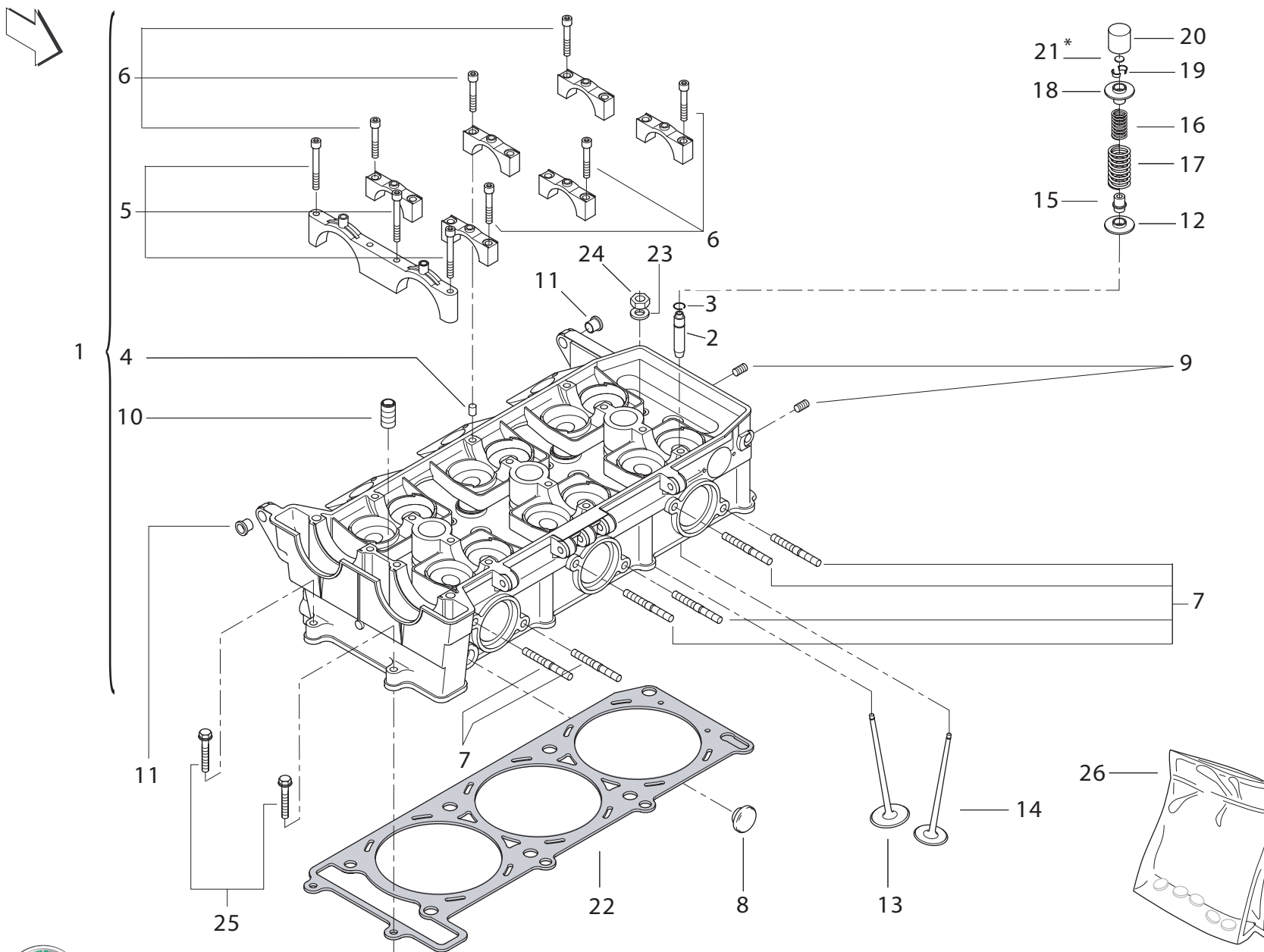

MISURA PASTIGLIA VALVOLE
VALVES PAD MEASURE
MESURE PASTILLE
MASS PASTILLE VENTIL
MEDIDA PASTILLA VÁLVULAS

Codice
Code
Code
Code
Codice

R14214641A	2,8 mm
R14214631A	2,775 mm
R14214621A	2,75 mm
R14214611A	2,725 mm
R14214601A	2,7 mm
R14214591A	2,675 mm
R14214581A	2,65 mm
R14214571A	2,625 mm
R14214561A	2,6 mm
R14214551A	2,575 mm
R14214541A	2,55 mm
R14214531A	2,525 mm
R14214521A	2,5 mm
R14214511A	2,475 mm
R14214501A	2,45 mm
R14214491A	2,425 mm
R14214481A	2,4 mm
R14214471A	2,375 mm
R14214461A	2,35 mm
R14214451A	2,325 mm
R14214441A	2,3 mm
R14214431A	2,275 mm
R14214421A	2,25 mm
R14214411A	2,225 mm
R14214401A	2,2 mm
R14214391A	2,175 mm
R14214381A	2,15 mm
R14214371A	2,275 mm
R14214361A	2,25 mm
R14214321A	2,000 mm
R14214331A	2,025 mm
R14214341A	2,050 mm
R14214351A	2,075 mm
R14214301A	1,950 mm
R14214311A	1,975 mm

POS. NO. N. INDEX POS.	N. CODICE CODE NO. Nr. CODE ATRIKEL Nr. CODICO Nr.	DESCRIZIONE	DESCRIPTION	DESIGNATION	BEZEICHNUNG	DENOMINACION	NOTE NOTES NOTES MARKE NOTAS	Q.TA' Q.TY Q.TE M.GE C.AD	
1	R300013001000	TESTA CILINDRO	CYLINDER HEAD	CYLINDRE TÊTE	ZYLINDERKOPFBEFESTIGUNG	CULATA CILINDRO		1	
2	R14013051A	GUIDA VALVOLA	VALVE GUIDE	GUIDE SOUPAPE	VENTILFÜHRUNG	GUÍA VÁLVULA		1	
3	R14013061A	ANELLINO DI FERMO	CHECK RING	BAGUE D'ARRÊT	SICHERUNGSRING	ANILLO DE BLOQUEO		1	
4	R16313361A	BUSSOLA	BUSH	DOUILLE	BUCHSE	CASQUILLO		1	
5	R90250740C	VITE	SCREW	VIS	SCHRAUBE	TORNILLO		3	
6	R90250720C	VITE	SCREW	VIS	SCHRAUBE	TORNILLO		6	
7	R14013111A	PRIGIONIERO	STUD BOLT	GOUJON	STIFTSCHRAUBE	TORNILLO SIN FIN		6	
8	R14043131A	TAPPO	CAP	BOUCHON	VERSCHLUß	TAPÓN		1	
9	R14043141A	TAPPO FILETTATO	THREADED CAP	BOUCHON FILETÉE	GEWINDE VERSCHLUß	TAPÓN FILETEADO		2	
10	R11043531A	TAPPO FILETTATO	THREADED CAP	BOUCHON FILETÉE	GEWINDE VERSCHLUß	TAPÓN FILETEADO		1	
11	R21213861A	BOCCOLA	BUSH	DOUILLE	BUCHSE	CASQUILLO		2	
12	R180217013000	SCODELLINO INFERIORE	LOWER CUP	COUPELLE D'APPUI	UNTERER BECHER	TAZA INFERIOR		1	
13	R180236121000	VALVOLA ASPIRAZIONE	INTAKE VALVE	SOUPAPE ADMISSION	EINLAßVENTIL	VÁLVULA DE ASPIRACIÓN		1	
14	R180236122000	VALVOLA DI SCARICO	EXHAUST VALVE	SOUPAPE D' ÉCHAPPEMENT	AUSLABVENTIL	VÁLVULA DE DESGARGA		1	
15	R14043121A	GOMMINO VALVOLA	RUBBER PAD VALVE	JOINT EN CAOUTCHOUC SOUPAPE	GOMMISTÜCK AUSLA	JUNTA DE GOMA VÁLVULA		1	
16	R14213051A	MOLLA INTERNA	INNER SPRING	RESSORT INTERNE	INNERE FEDER	MUELLE INTERIOR		1	
17	R14213041A	MOLLA ESTERNA	OUTER SPRING	RESSORT EXTERNE	ÄUßERE FEDER	MUELLE EXTERIOR		1	
18	R180236123000	SCODELLINO SUPERIORE	UPPER CUP	COUPELLE SUPERIEURE	OBERER BECHER	TAZA SUPERIOR		1	
19	R180236124000	SEMICONO	HALF CONE	DEMICONE	HALBKEGEL	SEMICONO		1	
20	R14213001B	BICCHIERINO	LIFTER BUCKET	POUSSOIR	BECHER	COPITA		1	
21	R14214641A	PASTIGLIA VALVOLA 2.8 mm	VALVE PAD	PASTILLE SOUPAPE	PASTILLEVENTIL	PASTILLA VÁLVULA		1	
21	R14214631A	PASTIGLIA VALVOLA 2.775mm	VALVE PAD	PASTILLE SOUPAPE	PASTILLEVENTIL	PASTILLA VÁLVULA		1	
21	R14214621A	PASTIGLIA VALVOLA 2.75mm	VALVE PAD	PASTILLE SOUPAPE	PASTILLEVENTIL	PASTILLA VÁLVULA		1	
21	R14214611A	PASTIGLIA VALVOLA 2.725 mm	VALVE PAD	PASTILLE SOUPAPE	PASTILLEVENTIL	PASTILLA VÁLVULA		1	

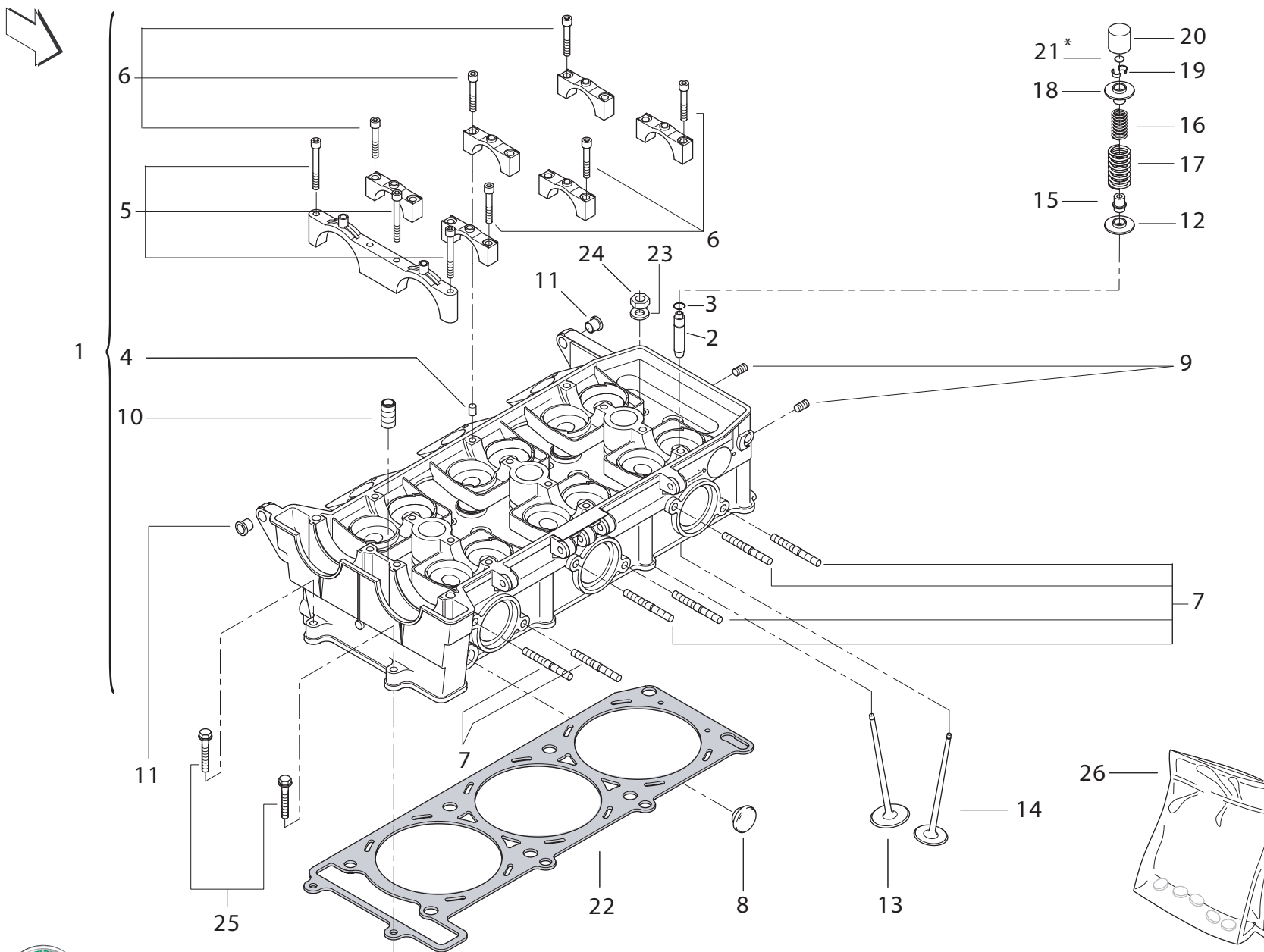

MISURA PASTIGLIA VALVOLE
VALVES PAD MEASURE
MESURE PASTILLE
MASS PASTILLE VENTIL
MEDIDA PASTILLA VÁLVULAS

Codice
Code
Code
Code
Codice

R14214641A	2,8 mm
R14214631A	2,775 mm
R14214621A	2,75 mm
R14214611A	2,725 mm
R14214601A	2,7 mm
R14214591A	2,675 mm
R14214581A	2,65 mm
R14214571A	2,625 mm
R14214561A	2,6 mm
R14214551A	2,575 mm
R14214541A	2,55 mm
R14214531A	2,525 mm
R14214521A	2,5 mm
R14214511A	2,475 mm
R14214501A	2,45 mm
R14214491A	2,425 mm
R14214481A	2,4 mm
R14214471A	2,375 mm
R14214461A	2,35 mm
R14214451A	2,325 mm
R14214441A	2,3 mm
R14214431A	2,275 mm
R14214421A	2,25 mm
R14214411A	2,225 mm
R14214401A	2,2 mm
R14214391A	2,175 mm
R14214381A	2,15 mm
R14214371A	2,275 mm
R14214361A	2,25 mm
R14214321A	2,000 mm
R14214331A	2,025 mm
R14214341A	2,050 mm
R14214351A	2,075 mm
R14214301A	1,950 mm
R14214311A	1,975 mm

POS. NO. N. INDEX POS.	N. CODICE CODE NO. Nr. CODE ATRIKEL Nr. CODICO Nr.	DESCRIZIONE	DESCRIPTION	DESIGNATION	BEZEICHNUNG	DENOMINACION	NOTE NOTES NOTES MARKE NOTAS	Q.TA' Q.TY Q.TE M.GE C.AD	
21	R14214601A	PASTIGLIA VALVOLA 2.7 mm	VALVE PAD	PASTILLE SOUPAPE	PASTILLEVENTIL	PASTILLA VÁLVULA		1	
21	R14214591A	PASTIGLIA VALVOLA 2.675 mm	VALVE PAD	PASTILLE SOUPAPE	PASTILLEVENTIL	PASTILLA VÁLVULA		1	
21	R14214581A	PASTIGLIA VALVOLA 2.65 mm	VALVE PAD	PASTILLE SOUPAPE	PASTILLEVENTIL	PASTILLA VÁLVULA		1	
21	R14214571A	PASTIGLIA VALVOLA 2.625 mm	VALVE PAD	PASTILLE SOUPAPE	PASTILLEVENTIL	PASTILLA VÁLVULA		1	
21	R14214561A	PASTIGLIA VALVOLA 2.6 mm	VALVE PAD	PASTILLE SOUPAPE	PASTILLEVENTIL	PASTILLA VÁLVULA		1	
21	R14214551A	PASTIGLIA VALVOLA 2.575 mm	VALVE PAD	PASTILLE SOUPAPE	PASTILLEVENTIL	PASTILLA VÁLVULA		1	
21	R14214541A	PASTIGLIA VALVOLA 2.55 mm	VALVE PAD	PASTILLE SOUPAPE	PASTILLEVENTIL	PASTILLA VÁLVULA		1	
21	R14214531A	PASTIGLIA VALVOLA 2.525 mm	VALVE PAD	PASTILLE SOUPAPE	PASTILLEVENTIL	PASTILLA VÁLVULA		1	
21	R14214521A	PASTIGLIA VALVOLA 2.5 mm	VALVE PAD	PASTILLE SOUPAPE	PASTILLEVENTIL	PASTILLA VÁLVULA		1	
21	R14214511A	PASTIGLIA VALVOLA 2.475 mm	VALVE PAD	PASTILLE SOUPAPE	PASTILLEVENTIL	PASTILLA VÁLVULA		1	
21	R14214501A	PASTIGLIA VALVOLA 2.45 mm	VALVE PAD	PASTILLE SOUPAPE	PASTILLEVENTIL	PASTILLA VÁLVULA		1	
21	R14214491A	PASTIGLIA VALVOLA 2.425 mm	VALVE PAD	PASTILLE SOUPAPE	PASTILLEVENTIL	PASTILLA VÁLVULA		1	
21	R14214481A	PASTIGLIA VALVOLA 2.4 mm	VALVE PAD	PASTILLE SOUPAPE	PASTILLEVENTIL	PASTILLA VÁLVULA		1	
21	R14214471A	PASTIGLIA VALVOLA 2.375 mm	VALVE PAD	PASTILLE SOUPAPE	PASTILLEVENTIL	PASTILLA VÁLVULA		1	
21	R14214461A	PASTIGLIA VALVOLA 2.35 mm	VALVE PAD	PASTILLE SOUPAPE	PASTILLEVENTIL	PASTILLA VÁLVULA		1	
21	R14214451A	PASTIGLIA VALVOLA 2.325 mm	VALVE PAD	PASTILLE SOUPAPE	PASTILLEVENTIL	PASTILLA VÁLVULA		1	
21	R14214441A	PASTIGLIA VALVOLA 2.3 mm	VALVE PAD	PASTILLE SOUPAPE	PASTILLEVENTIL	PASTILLA VÁLVULA		1	
21	R14214431A	PASTIGLIA VALVOLA 2.275 mm	VALVE PAD	PASTILLE SOUPAPE	PASTILLEVENTIL	PASTILLA VÁLVULA		1	
21	R14214421A	PASTIGLIA VALVOLA 2.25 mm	VALVE PAD	PASTILLE SOUPAPE	PASTILLEVENTIL	PASTILLA VÁLVULA		1	
21	R14214411A	PASTIGLIA VALVOLA 2.225 mm	VALVE PAD	PASTILLE SOUPAPE	PASTILLEVENTIL	PASTILLA VÁLVULA		1	
21	R14214401A	PASTIGLIA VALVOLA 2.2 mm	VALVE PAD	PASTILLE SOUPAPE	PASTILLEVENTIL	PASTILLA VÁLVULA		1	
21	R14214391A	PASTIGLIA VALVOLA 2.175 mm	VALVE PAD	PASTILLE SOUPAPE	PASTILLEVENTIL	PASTILLA VÁLVULA		1	
21	R14214381A	PASTIGLIA VALVOLA 2.15 mm	VALVE PAD	PASTILLE SOUPAPE	PASTILLEVENTIL	PASTILLA VÁLVULA		1	
21	R14214371A	PASTIGLIA VALVOLA 2.125 mm	VALVE PAD	PASTILLE SOUPAPE	PASTILLEVENTIL	PASTILLA VÁLVULA		1	

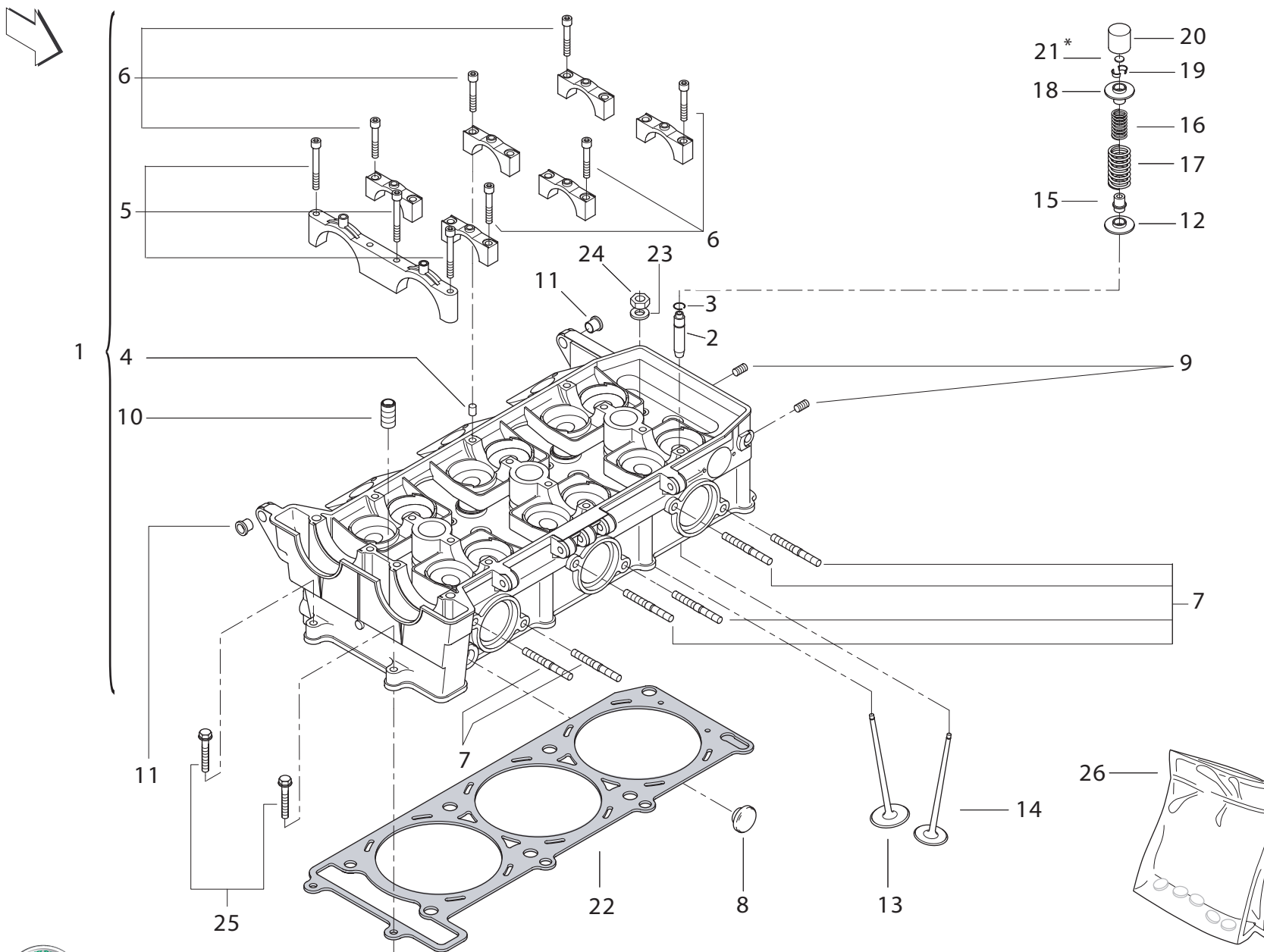

MISURA PASTIGLIA VALVOLE
VALVES PAD MEASURE
MESURE PASTILLE
MASS PASTILLE VENTIL
MEDIDA PASTILLA VÁLVULAS

Codice
Code
Code
Code
Codice

R14214641A	2,8 mm
R14214631A	2,775 mm
R14214621A	2,75 mm
R14214611A	2,725 mm
R14214601A	2,7 mm
R14214591A	2,675 mm
R14214581A	2,65 mm
R14214571A	2,625 mm
R14214561A	2,6 mm
R14214551A	2,575 mm
R14214541A	2,55 mm
R14214531A	2,525 mm
R14214521A	2,5 mm
R14214511A	2,475 mm
R14214501A	2,45 mm
R14214491A	2,425 mm
R14214481A	2,4 mm
R14214471A	2,375 mm
R14214461A	2,35 mm
R14214451A	2,325 mm
R14214441A	2,3 mm
R14214431A	2,275 mm
R14214421A	2,25 mm
R14214411A	2,225 mm
R14214401A	2,2 mm
R14214391A	2,175 mm
R14214381A	2,15 mm
R14214371A	2,275 mm
R14214361A	2,25 mm
R14214321A	2,000 mm
R14214331A	2,025 mm
R14214341A	2,050 mm
R14214351A	2,075 mm
R14214301A	1,950 mm
R14214311A	1,975 mm

POS. NO. N. INDEX POS.	N. CODICE CODE NO. Nr. CODE ATRIKEL Nr. CODICO Nr.	DESCRIZIONE	DESCRIPTION	DESIGNATION	BEZEICHNUNG	DENOMINACION	NOTE NOTES MARKE NOTAS	Q.TA' Q.TY Q.TE M.GE C.AD	
21	R14214361A	PASTIGLIA VALVOLA 2.1 mm	VALVE PAD	PASTILLE SOUPAPE	PASTILLEVENTIL	PASTILLA VÁLVULA		1	
21	R14214491A	PASTIGLIA VALVOLA 2.425 mm	VALVE PAD	PASTILLE SOUPAPE	PASTILLEVENTIL	PASTILLA VÁLVULA		1	
21	R14214321A	PASTIGLIA VALVOLA 2.000 mm	VALVE PAD	PASTILLE SOUPAPE	PASTILLEVENTIL	PASTILLA VÁLVULA		1	
21	R14214331A	PASTIGLIA VALVOLA 2.025 mm	VALVE PAD	PASTILLE SOUPAPE	PASTILLEVENTIL	PASTILLA VÁLVULA		1	
21	R14214341A	PASTIGLIA VALVOLA 2.050 mm	VALVE PAD	PASTILLE SOUPAPE	PASTILLEVENTIL	PASTILLA VÁLVULA		1	
21	R14214351A	PASTIGLIA VALVOLA 2.075 mm	VALVE PAD	PASTILLE SOUPAPE	PASTILLEVENTIL	PASTILLA VÁLVULA		1	
21	R14214301A	PASTIGLIA VALVOLA 1.950 mm	VALVE PAD	PASTILLE SOUPAPE	PASTILLEVENTIL	PASTILLA VÁLVULA		1	
21	R14214311A	PASTIGLIA VALVOLA 1.975 mm	VALVE PAD	PASTILLE SOUPAPE	PASTILLEVENTIL	PASTILLA VÁLVULA		1	
22	R14113111A	GUARNIZIONE	GASKET	GARNITURE	DICHTUNG	JUNTA		1	
23	R14413011A	RONDELLA	WASHER	RONDELLE	UNTERLEGSSCHEIBE	ARANDELA		1	
24	R14413031A	DADO	NUT	ECROU	MUTTER	TUERCA		1	
25	R90750712B	VITE	SCREW	VIS	SCHRAUBE	TORNILLO		2	
26	R300000183000	KIT REVISIONE PASTIGLIE VALVOLE	KIT VALVES PAD	KIT PASTILLE SOUPAPE	KIT PASTILLEVENTIL	KIT PASTILLE VÁLVULA		1	

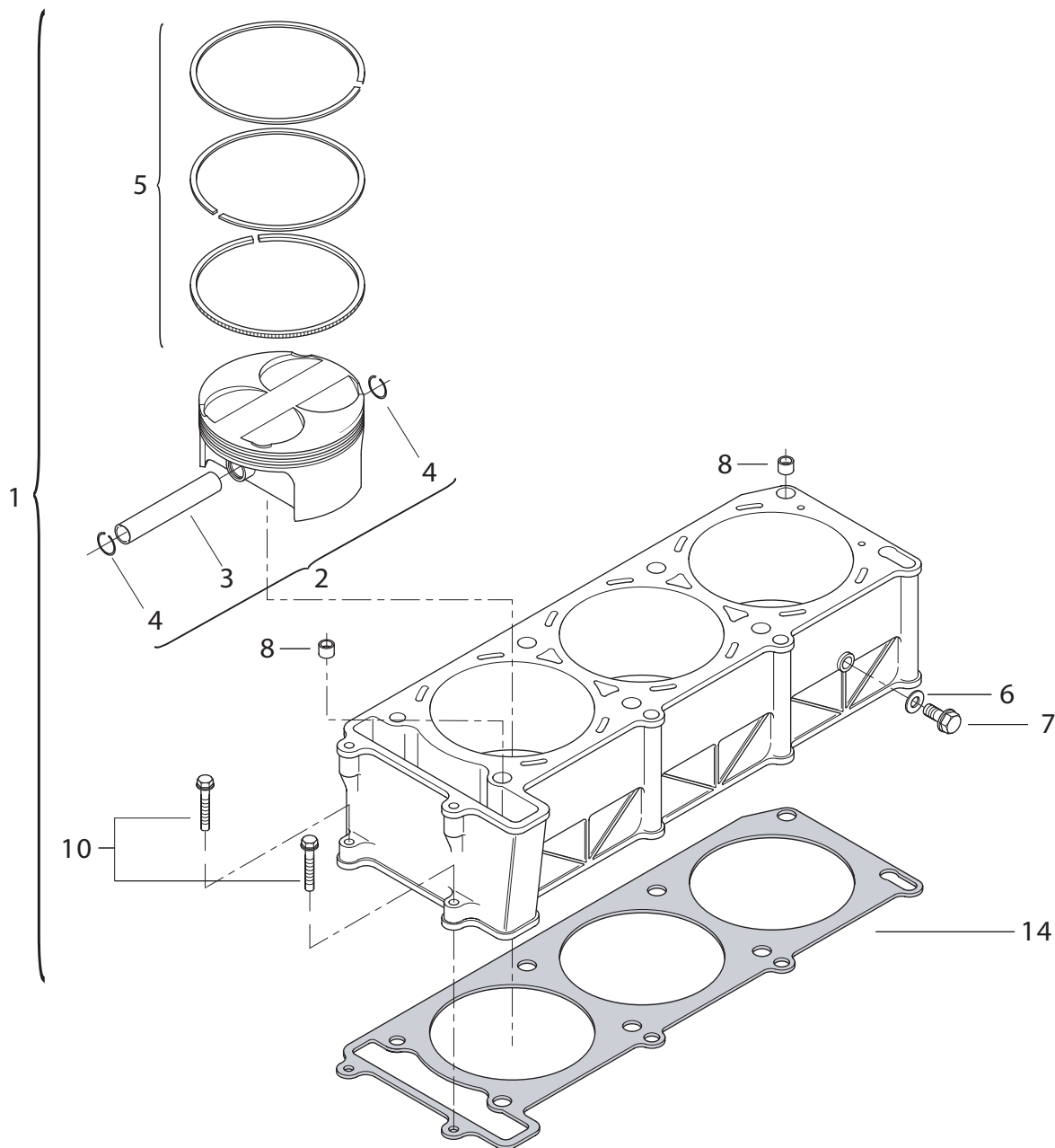
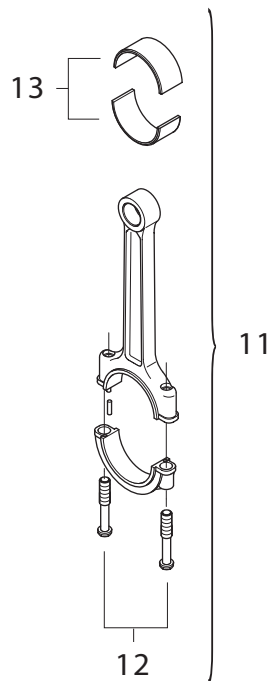
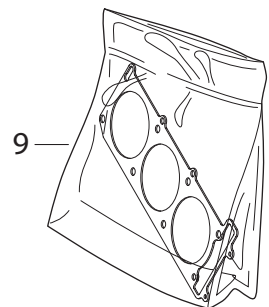



CILINDRO-PISTONI



CYLINDER-PISTONS



CYLINDRE-PISTONS



ZYLINDER-KOLBEN



CILINDRO-PISTONES

POS. NO. N. INDEX POS.	N. CODICE CODE NO. Nr. CODE ATRIKEL Nr. CODICO Nr.	DESCRIZIONE	DESCRIPTION	DESIGNATION	BEZEICHNUNG	DENOMINACION	NOTE NOTES NOTES MARKE NOTAS	Q.TA' Q.TY Q.TE M.GE C.AD	
1	R300000168000	CILINDRO COMPLETO	COMPLETE CYLINDER	CYLINDRE COMPLET	ZYLINDER KOMPLET	CILINDRO COMPLETO		1	
2	R300011002000	PISTONE COMPLETO "B"	COMPLETE PISTON "B"	PISTON COMPLET "B"	KOMPLETTER KOLBEN "B"	PISTÓN COMPLETO "B"		1	
2	R300011005000	PISTONE COMPLETO "A"	COMPLETE PISTON "A"	PISTON COMPLET "A"	KOMPLETTER KOLBEN "A"	PISTÓN COMPLETO "A"		1	
2	R300011006000	PISTONE COMPLETO "C"	COMPLETE PISTON "C"	PISTON COMPLET "C"	KOMPLETTER KOLBEN "C"	PISTÓN COMPLETO "C"		1	
3	R13213011A	SPINOTTO PER PISTONE	PISTON PIN	AXE DE PISTON	KOLBENBOLZEN	BULÓN		1	
4	R13213021A	ANELLO ELASTICO FERMA SPINOTTO	PISTON PIN CIRCLIP	BAGUE ÉLASTIQUE BLOQUE-AXE	SPRENGRING ZUR BOLZENFESTSTELLUNG	ANILLO ELÁSTICO BLOQUEA-CLAVIJA		2	
5	R180100133000	SERIE SEGMENTI PISTONE	PISTON RINGS SET	ETUI SEGMENTS	BEUTEL MIT KOLBENRINGEN	SERIE DE SEGMENTOS		1	
6	R17143231A	RONDELLA	WASHER	RONDELLE	UNTERLEGSCHIEBE	ARANDELA		1	
7	R90750632B	VITE	SCREW	VIS	SCHRAUBE	TORNILLO		1	
8	R14013151A	BOCCOLA	BUSH	DOUILLE	BUCHSE	CASQUILLO		2	
9	R310000077000	SERIE GUARNIZIONI CILINDRO-TESTA	HEAD-CYLINDER GASKETS SET	ETUI GARNITURES CYLINDRE-TÊTE	BEUTEL DICHTUNG ZYLINDER-KOPF	SERIE JUNTAS CILINDRO-CULATA		1	
10	R90750712B	VITE	SCREW	VIS	SCHRAUBE	TORNILLO		2	
11	R300009006000	BIELLA COMPLETA	COMPLETE CONNECTING ROD	BIELLE COMPLET	KOLBENSTANGE	BIELA COMPLETA		1	
12	R12213091A	VITE SPECIALE	SPECIAL SCREW	VIS SPÉCIALE	SPEZIALSCHRAUBE	TORNILLO ESPECIAL		2	
13	R180109001000	SEMICUSCINETTO DI BIELLA (BLUE)	HALF-BEARING (BLUE)	DEMI-ROULEMENT (BLUE)	HALBLAGER (BLAU)	SEMI-COJINETE (AZUL)		2	
13	R180109002000	SEMICUSCINETTO DI BIELLA (GIALLO)	HALF-BEARING (YELLOW)	DEMI-ROULEMENT (JAUNE)	HALBLAGER (GELB)	SEMI-COJINETE (AMARILLO)		2	
13	R180109000000	SEMICUSCINETTO DI BIELLA (ROSSO)	HALF-BEARING (RED)	DEMI-ROULEMENT (ROUGE)	HALBLAGER (ROT)	SEMI-COJINETE (ROJO)		2	
14	R13113051A	GUARNIZIONE CILINDRO CARTER	CYLINDER-CRANKCASE GASKET	GARNITURE CYLINDRE CARTER	ZYLINDER/ GEHÄUSEDICHTUNG	JUNTA CILINDRO CARTER		1	

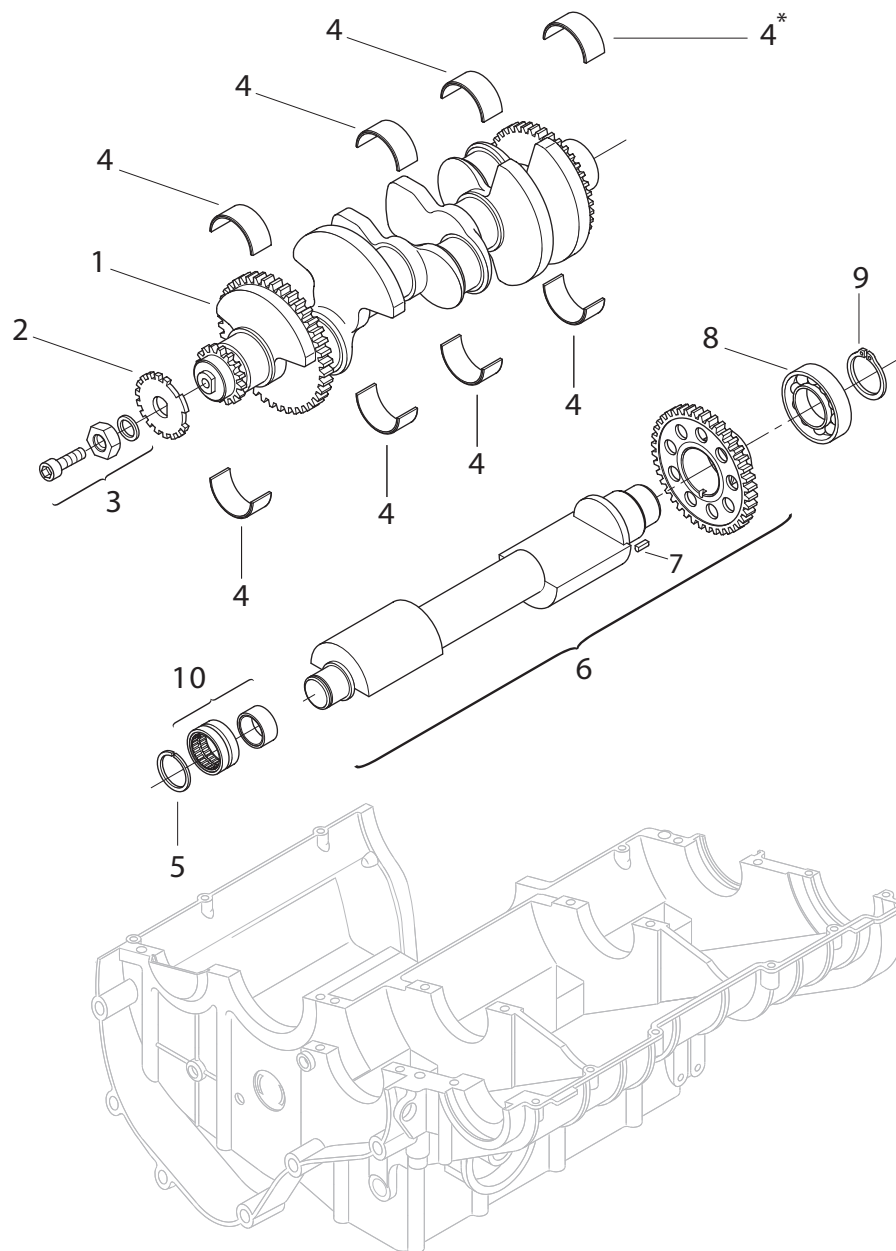

4*

SEMICUSCINETTO DI BANCO		
STD	COLORE COLOUR COULEUR FARBE COLOR	SELEZIONE SELECTION SELECTION AUSWAHL SELECCION
A	Rosso Red Rouge Rot Rojo	1.918 - 1.922
B	Blu Blue Bleu Blau Azul	1.922 - 1.926
C	Giallo Yellow Jaune Gelb Amarillo	1.926 - 1.930
Ø sede std A rosso Ø seat std A red Ø siège std A rouge Ø sitz std A rot Ø sede std A rojo		41.830 - 41.836
Ø sede std A blu Ø seat std A blue Ø siège std A bleu Ø sitz std A blau Ø sede std A azul		41.837 - 41.843
Ø sede std A giallo Ø seat std A yellow Ø siège std A jaune Ø sitz std A gelb Ø sede std A amarillo		41.843 - 41.850
Ø albero std unico Ø single std shaft Ø arbre std unique Ø welle std einheitl Ø arbol std único		37.960 - 37.970

POS. NO. N. INDEX POS.	N. CODICE CODE NO. Nr. CODE ATRIKEL Nr. CODICO Nr.	DESCRIZIONE	DESCRIPTION	DESIGNATION	BEZEICHNUNG	DENOMINACION	NOTE NOTES MARKE NOTAS	Q.TA' Q.TY Q.TE M.GE C.AD	
1	R300009003000	ALBERO MOTORE	CRANKSHAFT	ARBRE MOTEUR	ANTRIEBSWELLE	CIGUEÑAL		1	
2	R300033006000	RUOTA FONICA	WHEEL SPEED	ROUE PHONIQUE	GESCHWINDIGKEITS	RUEDA FÓNICA		1	
3	R300000179000	KIT FISSAGGIO RUOTA FONICA	KIT WHEEL SPEED	KIT ROUE PHONIQUE	KIT GESCHWINDIGKEITS	KIT RUEDA FÓNICA		1	
4	R180102000000	SEMICUSCINETTO ROSSO	RED HALF-BEARING	DEMI-ROULEMENT ROUGE	HALBLAGER ROT	SEMI-COJINETE ROJO		2	
4	R180102001000	SEMICUSCINETTO BLU	BLUE HALF-BEARING	DEMI-ROULEMENT BLEU	HALBLAGER BLAU	SEMI-COJINETE AZUL		2	
4	R180102002000	SEMICUSCINETTO GIALLO	YELLOW HALF-BEARING	DEMI-ROULEMENT JAUNE	HALBLAGER GELB	SEMI-COJINETE AMARILLO		2	
5	R92450250D	ANELLO ELASTICO	SNAP RING	BAGUE ÉLASTIQUE	SPRENGRING	SEAGER		1	
6	R300009010000	ALBERO DI BILANCIAMENTO	BALANCE SHAFT	AXE D'ÉQUILIBRE	BALANCE WELLE	EJE DEL BALANCE		1	
7	R92750389C	RULLO	ROLLER CAGE	ROULEAU	RULO	RODILLO		1	
8	R12443081A	CUSCINETTO A SFERE	BALL BEARING	ROULEMANT À BILLES	KUGELLAGER	RODAMIENTO DE BOLAS		1	
9	R92452200D	ANELLO ELASTICO	SNAP RING	BAGUE ÉLASTIQUE	SPRENGRING	SEAGER		1	
10	R12443221A	CUSCINETTO A RULLI	ROLLER BEARING	COUSSINET A ROULEAUX	ROLLENLAGER	COJINETE RODILLOS		1	

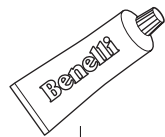

12

11

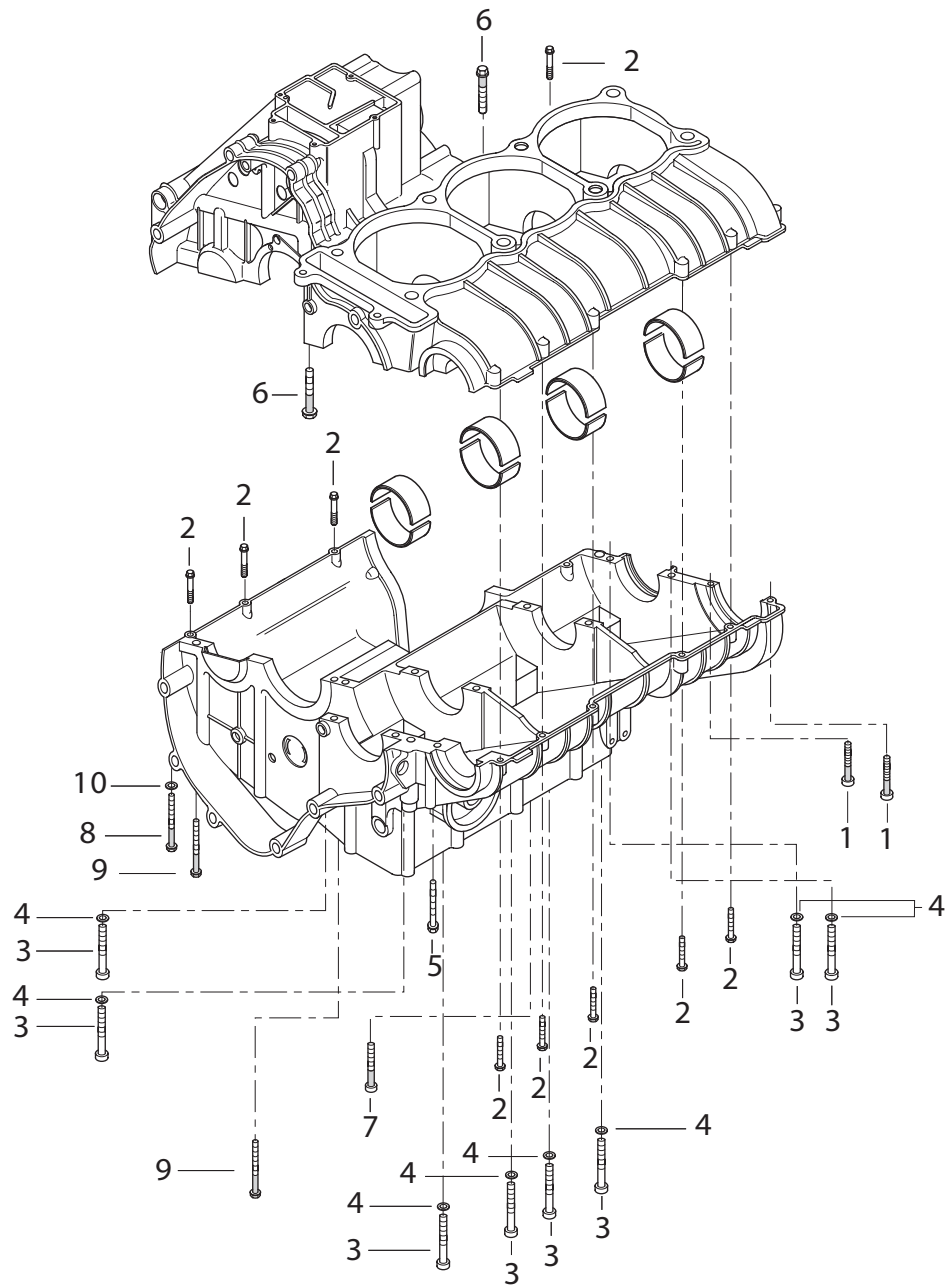



COPPIA SEMICARTER



HALF CRANKCASES



DEMI-CARTERS



GEHÄUSEHÄLFTE



PAREJA SEMI-CARTER

POS. NO. N. INDEX POS.	N. CODICE CODE NO. Nr. CODE ATRIKEL Nr. CODICO Nr.	DESCRIZIONE	DESCRIPTION	DESIGNATION	BEZEICHNUNG	DENOMINACION	NOTE NOTES MARKE NOTAS	Q.TA' Q.TY Q.TE M.GE C.AD	
1	R90751492B	VITE	SCREW	VIS	SCHRAUBE	TORNILLO		2	
2	R90750722B	VITE	SCREW	VIS	SCHRAUBE	TORNILLO		9	
3	R90254470C	VITE	SCREW	VIS	SCHRAUBE	TORNILLO		8	
4	R180204017000	RONDELLA	WASHER	RONDELLE	UNTERLESCHIEBE	ARANDELA		8	
5	R90750772B	VITE	SCREW	VIS	SCHRAUBE	TORNILLO		1	
6	R90751292B	VITE	SCREW	VIS	SCHRAUBE	TORNILLO		2	
7	R90251370C	VITE	SCREW	VIS	SCHRAUBE	TORNILLO		1	
8	R90251410C	VITE	SCREW	VIS	SCHRAUBE	TORNILLO		1	
9	R90251430C	VITE	SCREW	VIS	SCHRAUBE	TORNILLO		2	
10	R92050187A	RONDELLA	WASHER	RONDELLE	UNTERLESCHIEBE	ARANDELA		1	
11	R180200165B33	COPPIA SEMICARTER	HALF CRANKCASES	DEMI-CARTERS	GEHÄUSEHÄLFTE	PAREJA SEMI-CARTER		1	
12	R310091014000	GUARNIZIONE LIQUIDA	FLUID SEALANT	COLLE LIQUIDE POUR JOINT	FLÜSSIGE DICHTUNG	SELLADOR JUNTA LÍQUIDA		1	

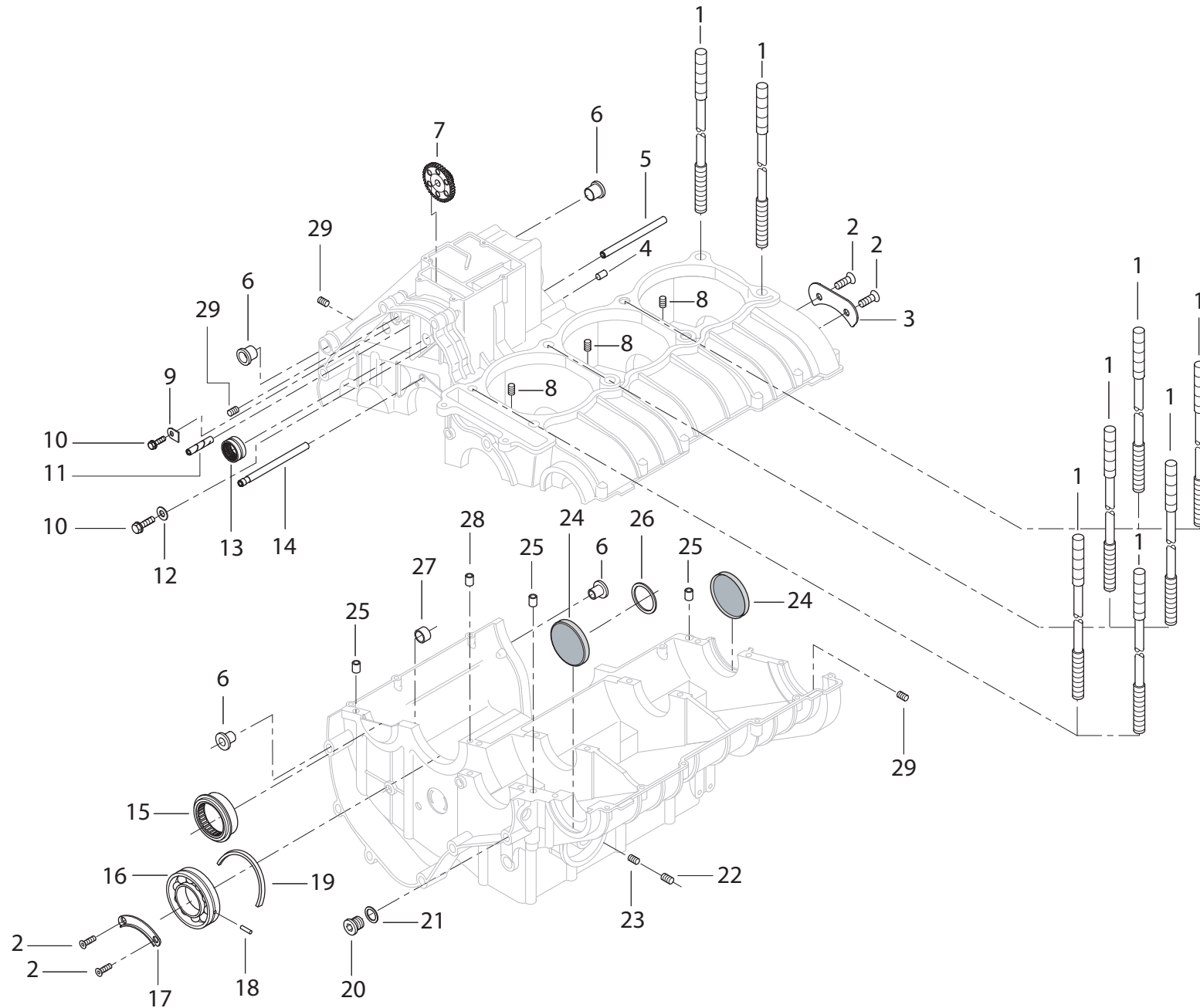

POS. NO. N. INDEX POS.	N. CODICE CODE NO. Nr. CODE ATRIKEL Nr. CODICO Nr.	DESCRIZIONE	DESCRIPTION	DESIGNATION	BEZEICHNUNG	DENOMINACION	NOTE NOTES NOTES MARKE NOTAS	Q.TA' Q.TY Q.TE M.GE C.AD	
1	R14413061A	PRIGIONIERO TESTA	HEAD STUD BOLT	GOUJON CULASSE	STIFTSCHRAUBE ZILINDERKOPF	TORNILLO SIN FIN CULATA		8	
2	R90650502B	VITE	SCREW	VIS	SCHRAUBE	TORNILLO		4	
3	R11013251A	PIASTRINA	PLATE	PLAQUETTE	PLÄTTCHEN	PLACA		1	
4	R16313041A	BUSSOLA	BUSH	DOUILLE	BUCHSE	CASQUILLO		1	
5	R180207009000	TUBO OLIO	OIL PIPE	CONDUITE D' HUILE	ÖLLEITUNG	TUBO ACEITE		1	
6	R21213861A	BOCCOLA	BUSH	DOUILLE	BUCHSE	CASQUILLO		4	
7	R180200040000	INGRANAGGIO Z17/67	GEAR Z17/67	ENGRENAGE Z17/67	ZAHNRAD Z17/67	ENGRANAJE Z17/67		1	
8	R180107000000	GETTO OLIO	OIL JET	JET D' HUILE	ÖLSTRAHL	CHORRO ACEITE		3	
9	R11013091A	PIASTRINO	PLATE	PLAQUETTE	PLÄTTCHEN	LÁMINA		1	
10	R90750652B	VITE	SCREW	VIS	SCHRAUBE	TORNILLO		2	
11	R19113041A	ALBERINO INGRANAGGI	GEARS SHAFT	ARBRE ENGRENAGE	ZAHNRADSPINDEL	ÁRBOL ENGRANAJES		1	
12	R16313211A	RONDELLA	WASHER	RONDELLE	UNTERLEGSCHIEBE	ARANDELA		1	
13	R11043141A	CUSCINETTO A RULLI	ROLLER BEARING	COUSSINET A ROULEAUX	ROLLENLAGER	COJINETE RODILLOS		1	
14	R11023781A	TUBO	TUBE	TUBE	ROHR	TUBO		1	
15	R11043921A	CUSCINETTO A RULLI	ROLLER BEARING	COUSSINET A ROULEAUX	ROLLENLAGER	COJINETE RODILLOS		1	
16	R16344151A	CUSCINETTO	BEARING	ROULEMENT	LAGER	COJINETE		1	
17	R11013711A	PIASTRINA	PLATE	PLAQUETTE	PLÄTTCHEN	PLACA		1	
18	R11043431A	SPINA	PIN	GOUPILLE	STIFT	PASADOR		1	
19	R180357182000	ANELLO CUSCINETTO	BEARING RING	BAGUE ROULEMENT	RING LAGER	ANILLO COJINETE		1	
20	R11043501A	TAPPO	CAP	BOUCHON	VERSCHLUß	TAPÓN		1	
21	R11043491A	RONDELLA DI TENUTA	STOP WASHER	RONDELLE D' ETANCHÉITÉ	DICHTUNGSRING	ARANDELA DE RETÉN		1	
22	R11043481A	TAPPO FILETTATO	THREADED CAP	BOUCHON FILETÉE	GEWINDEVERSCHLUß	TAPÓN FILETEADO		1	
23	R11013811A	GRANO	DOWEL	VIS SANS TÊTE	STIFT	CLAVIJA		1	
24	R11043071A	COPERCHIO	COVER	COUVERCLE	DECKEL	TAPA		2	

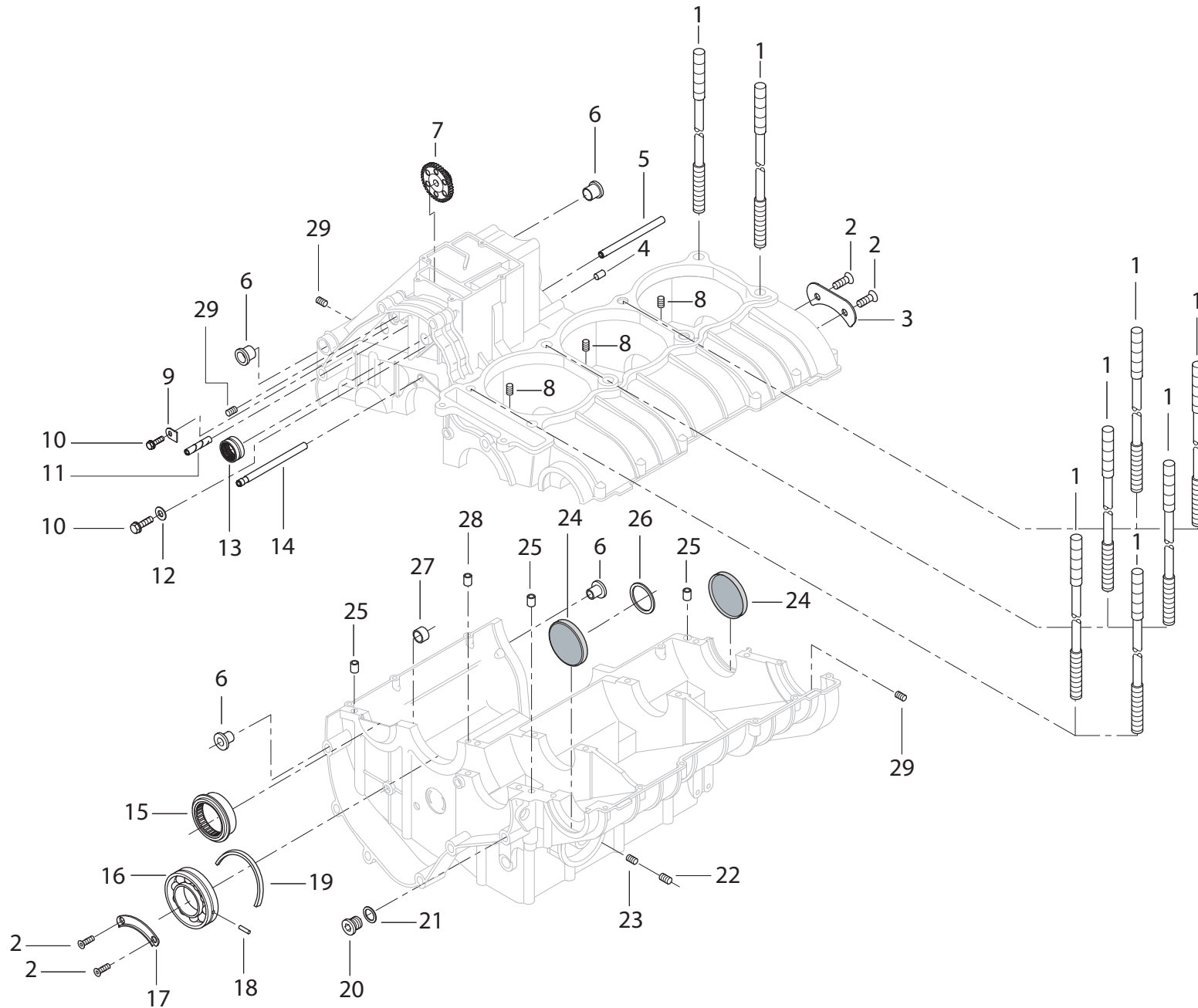

POS. NO. N. INDEX POS.	N. CODICE CODE NO. Nr. CODE ATRIKEL Nr. CODICO Nr.	DESCRIZIONE	DESCRIPTION	DESIGNATION	BEZEICHNUNG	DENOMINACION	NOTE NOTES NOTES MARKE NOTAS	Q.TA' Q.TY Q.TE M.GE C.AD	
25	R11013081A	BUSSOLA DI CENTRAGGIO	CENTRING BUSH	DOUILLE DE CENTRAGE	ZENTRIERBUCHSE	CASQUILLO DE CENTRADO		3	
26	R11013761A	ANELLO	RING	BAGUE	RING	ANILLO		1	
27	R11043161A	BOCCOLA	BUSH	DOUILLE	BUCHSE	CASQUILLO		1	
28	R16313361A	BUSSOLA DI CENTRAGGIO	CENTRING BUSH	DOUILLE DE CENTRAGE	ZENTRIERBUCHSE	CASQUILLO DE CENTRADO		1	
29	R14043141A	GRANO	DOWEL	VIS SANS TÊTE	STIFT	CLAVIJA		3	



COPERCHI MOTORE



ENGINE COVERS



COUVERCLES MOTEUR



MOTOR DECKEL



TAPAS MOTOR

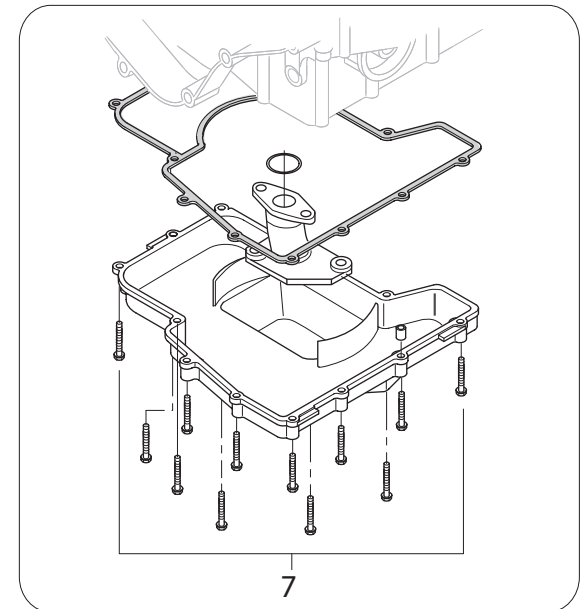
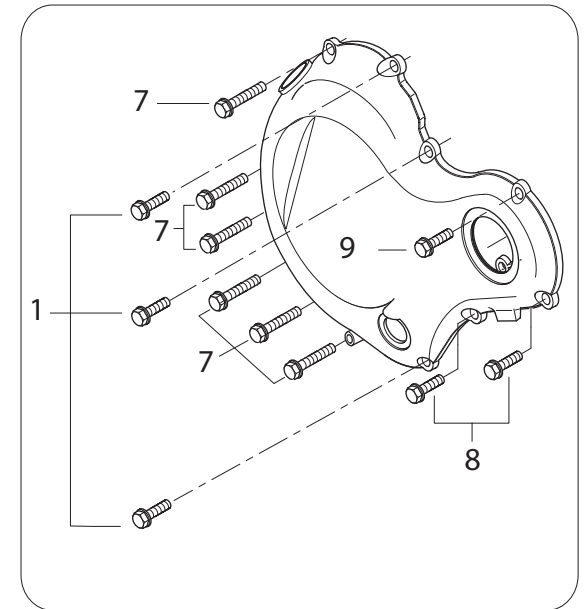
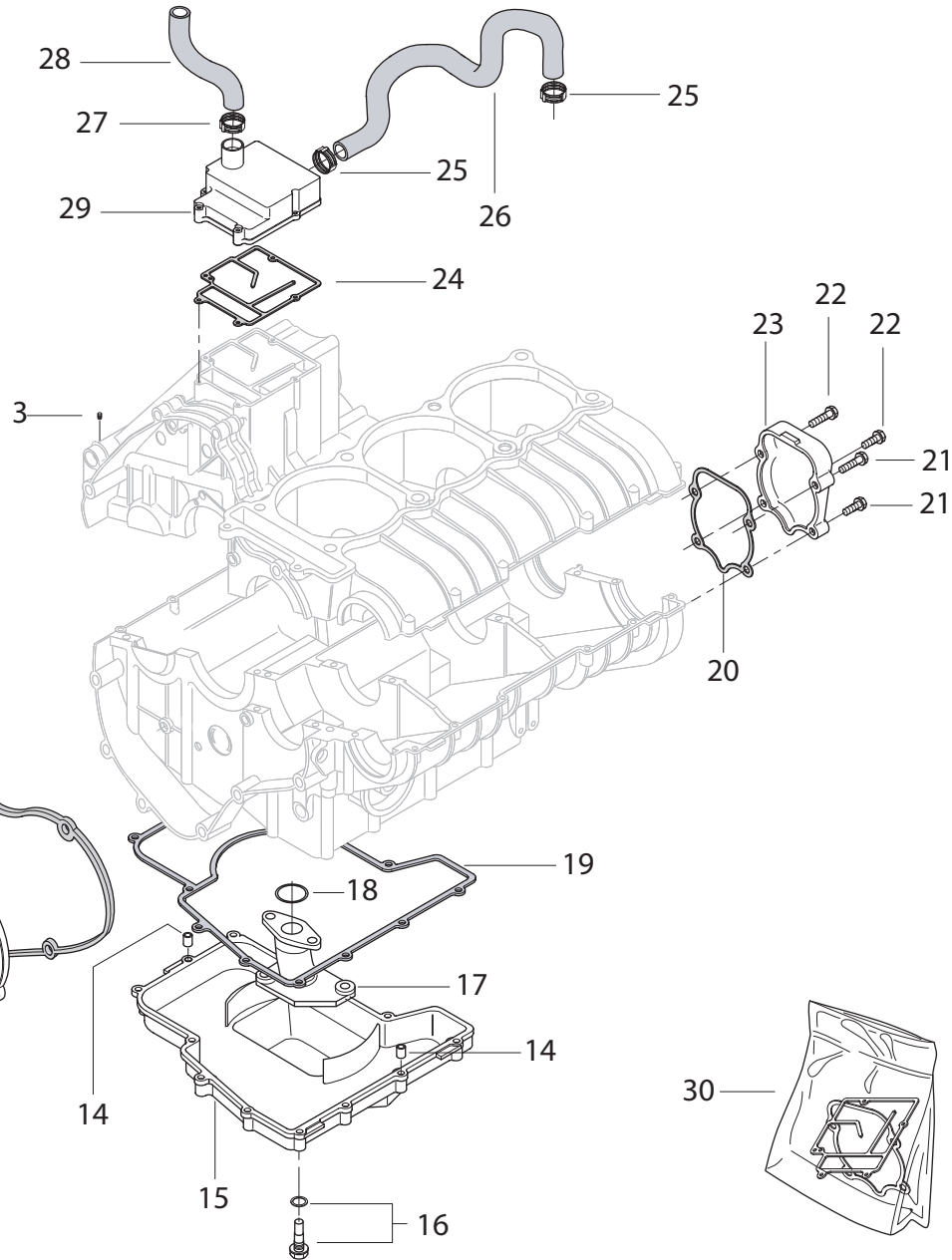
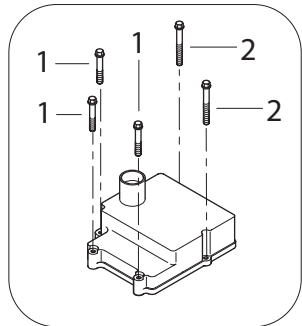



COPERCHI MOTORE



ENGINE COVERS



COUVERCLES MOTEUR



MOTOR DECKEL



TAPAS MOTOR

POS. NO. N. INDEX POS.	N. CODICE CODE NO. Nr. CODE ATRIKEL Nr. CODICO Nr.	DESCRIZIONE	DESCRIPTION	DESIGNATION	BEZEICHNUNG	DENOMINACION	NOTE NOTES NOTES MARKE NOTAS	Q.TA' Q.TY Q.TE M.GE C.AD	
1	R90750692B	VITE	SCREW	VIS	SCHRAUBE	TORNILLO		6	
2	R90750722B	VITE	SCREW	VIS	SCHRAUBE	TORNILLO		2	
3	R14043141A	TAPPO FILETTATO	THREADED CAP	BOUCHON FILETÉE	GEWINDE VERSCHLUß	TAPÓN FILETEADO		1	
4	R11013681A	GUARNIZIONE COPERCHIO FRIZIONE	CLUTCH COVER GASKET	GARNITURE COUVERCLE EMBRAYAGE	DECKEL DICHTUNG KUPPLUNG	JUNTA TAPA EMBRAGUE		1	
5	R92850109M	GUARNIZIONE OR	O-RING	JOINT D'ÉTANCHÉITÉ	DICHTUNG OR	JUNTA OR		1	
6	R11013401A	TAPPO CARICO OLIO	OIL LOAD PLUG	BOUCHON REMPLISSAGE HUILE	ÖLEINFÜLLSCHRAUBE	TAPÓN CARGO ACEITE		1	
7	R90750712B	VITE	SCREW	VIS	SCHRAUBE	TORNILLO		18	
8	R90750672B	VITE	SCREW	VIS	SCHRAUBE	TORNILLO		2	
9	R90750652B	VITE	SCREW	VIS	SCHRAUBE	TORNILLO		1	
10	R11013911A	TAPPO FASE	PHASE PLUG	BOUCHON PHASE	PHASENSCHRAUBE	TAPÓN FASE		1	
11	R92850259M	GUARNIZIONE OR	O-RING	JOINT D'ÉTANCHÉITÉ	DICHTUNG OR	JUNTA OR		1	
12	R11043391A	OBLO' ISPEZIONE LIVELLO OLIO	OIL LEVEL SIGHT GLASS	HUBLOT D'INPECTION NIVEAU HUILE	ÖLKONTROLLSCHAUGLAS	VISOR EN INSPECCIÓN NIVEL		1	
13	R180201005000	COPERCHIO FRIZIONE	CLUTCH COVER	COUVERCLE EMBRAYAGE	KUPPLUNGSDECKEL	TAPA EMBRAGUE		1	
14	R16313361A	BUSSOLA	BUSH	DOUILLE	BUCHSE	CASQUILLO		2	
15	R180201004000	COPPA OLIO	OIL SUMP	CARTER INFERIEUR (HUILE)	ÖLWANNE	COPA ACEITE		1	
16	R180270005000	TAPPO MAGNETICO	MAGNETIC CAP	BOUCHON MAGNÉTIQUE	MAGNETDECKEL	TAPÓN MAGNÉTICO		1	
17	R180201033001	FILTRO ASPIRAZIONE	INTAKE FILTER	FILTRE ASPIRATION	ANSAUGFILTER	FILTRO ASPRACIÓN		1	
18	R92850139M	GUARNIZIONE OR	O-RING	JOINT D'ÉTANCHÉITÉ	DICHTUNG OR	JUNTA OR		1	
19	R11013791A	GUARNIZIONE COPPA OLIO	OIL SUMP GASKET	GARNITURE CARTER INFERIEUR (HUILE)	DICHTUNG ÖLWANNE	JUNTA COPA ACEITE		1	
20	R11013221A	GUARNIZIONE COPERCHIO	COVER GASKET	GARNITURE COUVERCLE	DECKELDICHTUNG	JUNTA TAPA		1	
21	R90750512B	VITE	SCREW	VIS	SCHRAUBE	TORNILLO		2	
22	R90750532B	VITE	SCREW	VIS	SCHRAUBE	TORNILLO		2	
23	R1802010100CE	COPERCHIO	COVER	COUVERCLE	DECKEL	TAPA		1	
24	R11013241A	GUARNIZIONE COPERCHIO BLOW-BY	BLOW-BY COVER GASKET	GARNITURE COUVERCLE BLOW-BY	DECKELDICHTUNG BLOW-BY	JUNTA TAPA BLOW-BY		1	



COPERCHI MOTORE



ENGINE COVERS



COUVERCLES MOTEUR



MOTOR DECKEL



TAPAS MOTOR

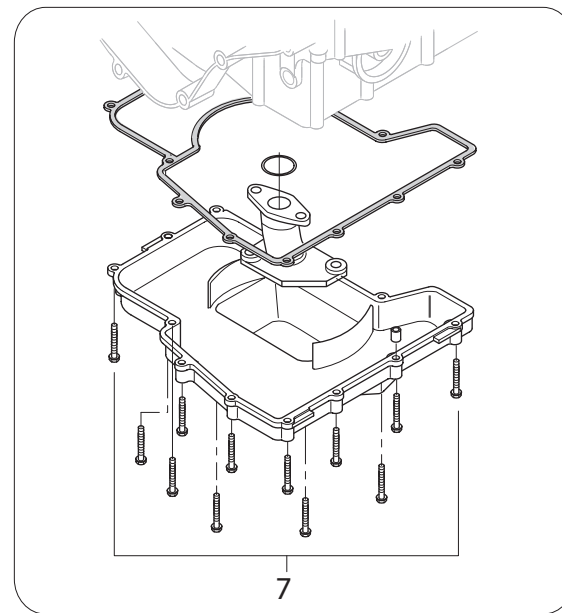
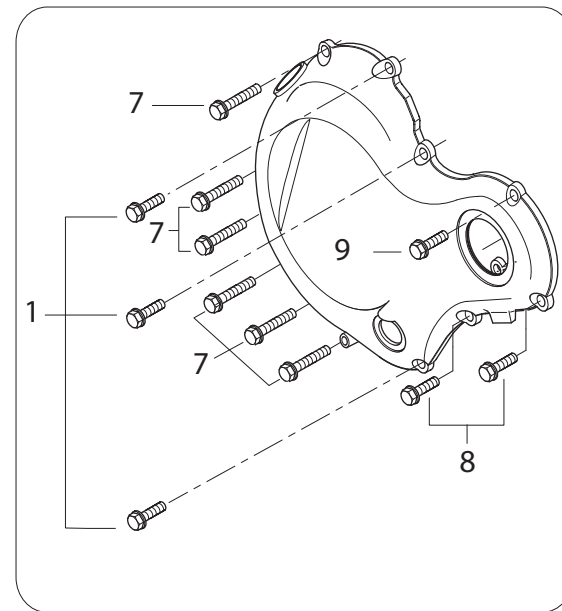
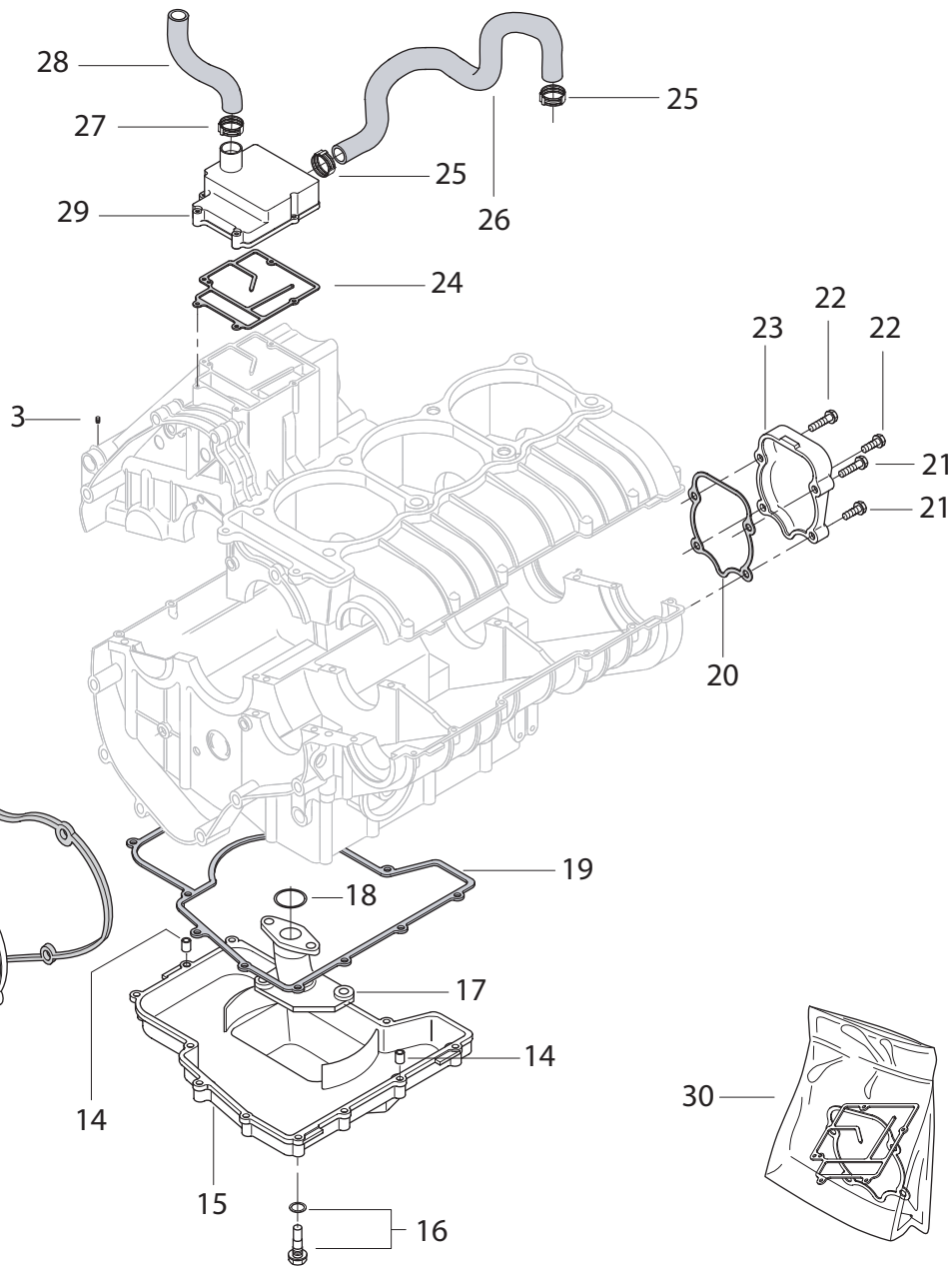
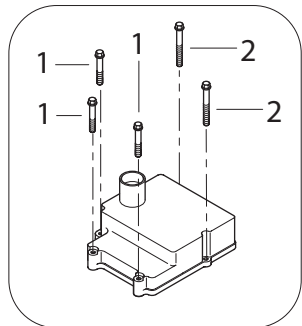



COPERCHI MOTORE



ENGINE COVERS



COUVERCLES MOTEUR



MOTOR DECKEL



TAPAS MOTOR

POS. NO. N. INDEX POS.	N. CODICE CODE NO. Nr. CODE ATRIKEL Nr. CODICO Nr.	DESCRIZIONE	DESCRIPTION	DESIGNATION	BEZEICHNUNG	DENOMINACION	NOTE NOTES MARKE NOTAS	Q.TA' Q.TY Q.TE M.GE C.AD	
25	R180184002000	FASCETTA	CLAMP	COLLIER	SHELLE	ABRAZADERA		2	
26	R180107003000	TUBO SFIATO TESTA	HEAD VENT PIPE	TUBE EVENT TETE	EVENTLUFTÜNGSSCHLAUCH KOPF	TUBO RESPIRADERO CABEZA		1	
27	R180184000000	FASCETTA	CLAMP	COLLIER	SHELLE	ABRAZADERA		1	
28	R180190118000	TUBO SFIATO OLIO	OIL BREATHER TUBE	TUBE D' EVENT HUILE	ÖLENTLÜFERROHR	TUBO RESPIRADERO ACEITE		1	
29	R180201019000	COPERCHIO BLOW-BY	BLOW-BY COVER	COUVERCLE BLOW-BY	DECKEL BLOW-BY	TAPA BLOW-BY		1	
30	R180200152000	KIT GUARNIZIONI CARTER	GASKET KIT	JEU GARNITURE	KIT DICHTUNG	KIT JUNTA		1	

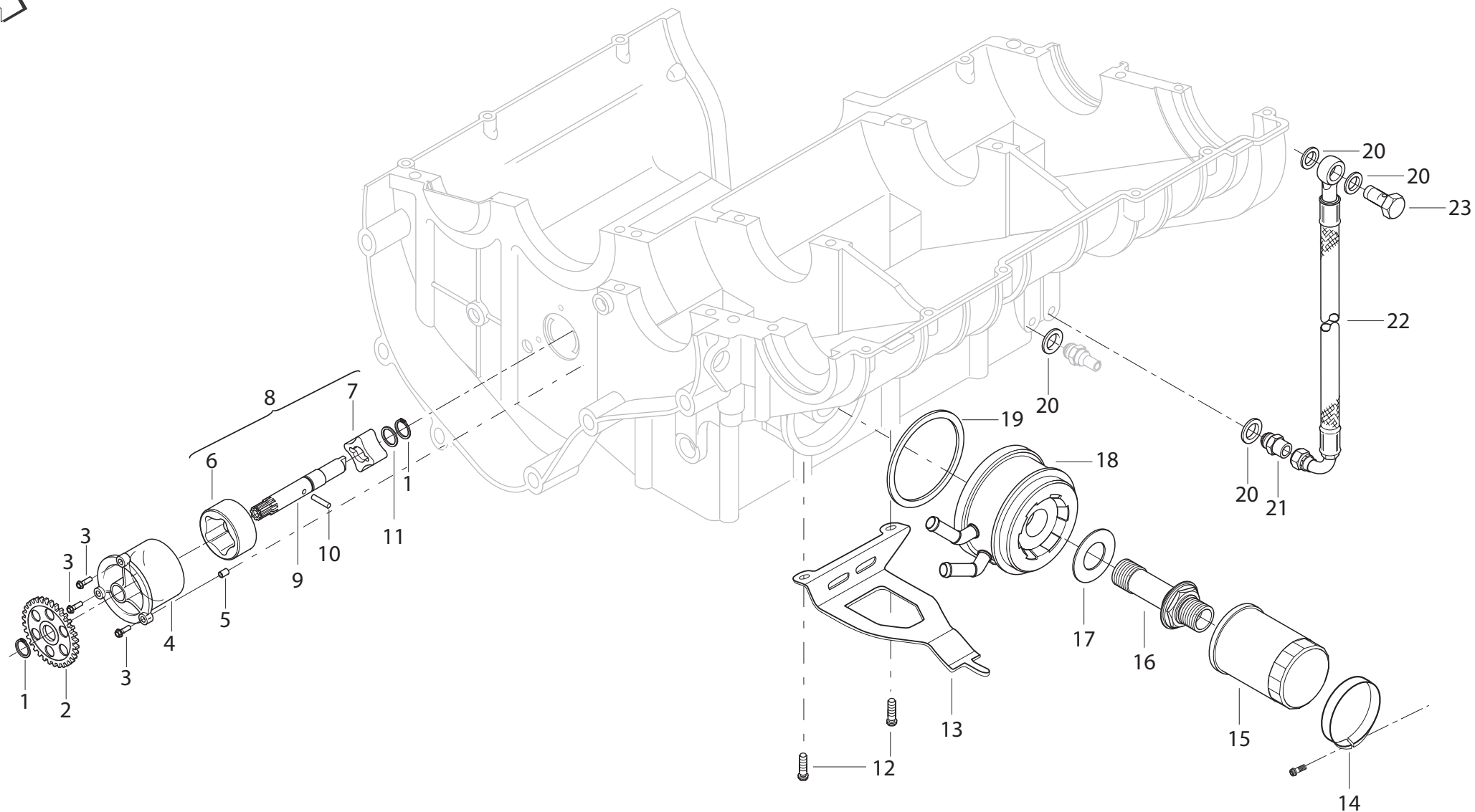

POS. NO. N. INDEX POS.	N. CODICE CODE NO. Nr. CODE ATRIKEL Nr. CODICO Nr.	DESCRIZIONE	DESCRIPTION	DESIGNATION	BEZEICHNUNG	DENOMINACION	NOTE NOTES NOTES MARKE NOTAS	Q.TA' Q.TY Q.TE M.GE C.AD	
1	R11613091A	RASAMENTO	SHIM	ROSETTE DE BUTÉE ÉPAISSEUR	DISTANZSCHEIBE STÄRKE	ARANDELA DE ESPESORACIÓN		2	
2	R11613081A	INGRANAGGIO DI COMANDO Z 34	DRIVE GEAR Z 34	ENGRENAGE COMMANDE Z 34	DREHSTOMGENERATOR Z 34	ENGRANAJE MANDO Z 34		1	
3	R90750672B	VITE	SCREW	VIS	SCHRAUBE	TORNILLO		3	
4	R180206001000	POMPA OLIO	OIL PUMP	POMPE À HUILE	ÖLPUMPE	BOMBA ACEITE		1	
5	R11613101A	BUSSOLA	BUSH	DOUILLE	BUCHSE	CASQUILLO		1	
6	R11613031A	ROTORE ESTERNO	OUTER ROTORS	EXTERNE ROTORS	ROTOREN DECKEL	ROTOR EXTERIOR		1	
7	R11613021A	ROTORE INTERNO	INNER ROTORS	INTERNE ROTORS	ROTOREN INNERES	ROTOR INTERIOR		1	
8	R180106003000	ROTORI POMPA OLIO	OIL PUMP ROTORS	POMPE À HUILE ROTORS	ROTOREN ÖLPUMPE	ROTOR BOMBA ACEITE		1	
9	R11613111A	ALBERO POMPA OLIO	OIL PUMP SHAFT	ARBRE POMPE À HUILE	WELLE ÖLPUMPE	ÁRBOL BOMBA ACEITE		1	
10	R92750839C	RULLO	ROLLER	ROULEAU	ROLLE	RODILLO		1	
11	R16044401A	ANELLO DI TENUTA	SEAL RING	BAGUE D'ÉTANCHÉITÉ	DICHTRING	ANILLO DE RETÉN		1	
12	R90750712B	VITE	SCREW	VIS	SCHRAUBE	TORNILLO		2	
13	R310057150000	PIASTRA	PLATE	PLAQUE	PLATTE	SOPORTE		1	
14	R18343751A	FASCETTA	CLAMP	COLLIER	SHELLE	ABRAZADERA		1	
15	R180107101000	FILTRO OLIO	OIL FILTER	FILTRE À HUILE	ÖLFILTER	FILTRO ACEITE		1	
16	R11513471A	VITE SPACIALE	SPECIAL SCREW	VIS SPÉCIALE	SPEZIALSCHRAUBE	TORNILLO ESPECIAL		1	
17	R11543481A	RASAMENTO	SHIM	ROSETTE DE BUTÉE ÉPAISSEUR	DISTANZSCHEIBE STÄRKE	ARANDELA DE ESPESORACIÓN		1	
18	R11543321A	SCAMBIATORE ACQUA OLIO COMPLETO	WATER OIL EXCHANGER COMPLETE	ÉCHANGEUR COMPLET D'HUILE DE L'EAU	AUSTAUSCHER WASSER-ÖL KOMPLETT	CAMBIADOR COMPLETO DEL ACEITE DEL AGUA		1	
19	R180407017000	ANELLO DI TENUTA	SEAL RING	BAGUE D'ÉTANCHÉITÉ	DICHTRING	ANILLO DE RETÉN		1	
20	R180132106000	RONDELLA	WASHER	RONDELLE	UNTERLEGSCHIEBE	ARANDELA		4	
21	R11543451A	RACCORDO	UNION	RACCORD	ANSCHLUß	EMPALME		1	
22	R11513431A	TUBO	TUBE	TUBE	ROHR	TUBO		1	
23	R11543591A	VITE SPECIALE	SPECIAL SCREW	VIS SPÉCIALE	SPEZIALSCHRAUBE	TORNILLO ESPECIAL		1	

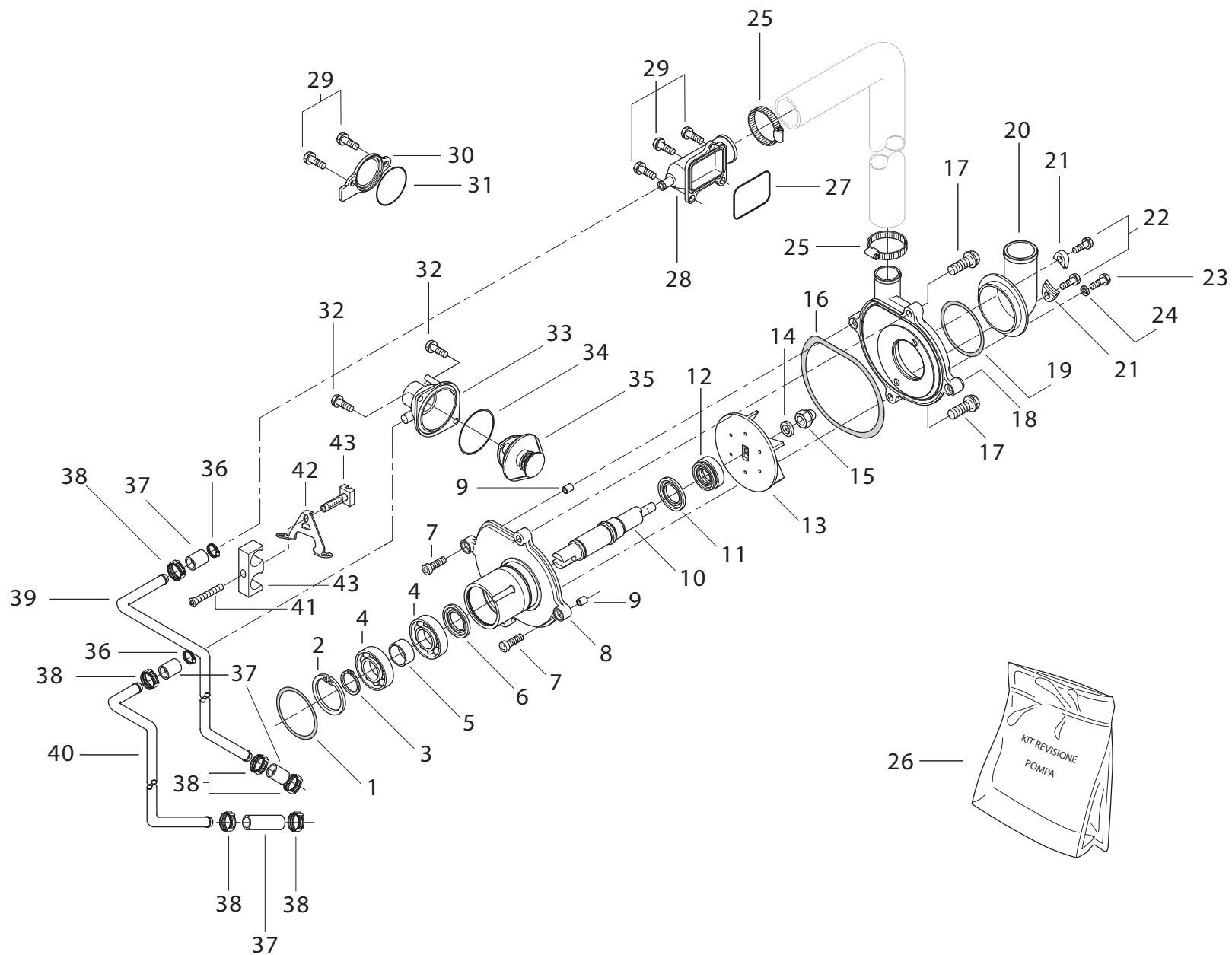

POS. NO. N. INDEX POS.	N. CODICE CODE NO. Nr. CODE ATRIKEL Nr. CODICO Nr.	DESCRIZIONE	DESCRIPTION	DESIGNATION	BEZEICHNUNG	DENOMINACION	NOTE NOTES NOTES MARKE NOTAS	Q.TA' Q.TY Q.TE M.GE C.AD	
1	R92850049M	ANELLO DI TENUTA	SEAL RING	BAGUE D'ÉTANCHÉITÉ	DICHTRING	ANILLO DE RETÉN		1	
2	R92550320D	SEEGER INTERNO	INNER SEEGER	CIRCLIP INTERNE	SEEGER INNEN	SEEGER INTERIOR		1	
3	R92450150D	SEEGER ESTERNO	OUTER SEEGER	CIRCLIP EXTERNE	SEEGER AUSSEN	SEEGER EXTERIOR		1	
4	R17143211A	CUSCINETTO	BEARING	ROULEMENT	LAGER	COJINETE		2	
5	R17113111A	DISTANZIALE	SPACER	ENTRETOISE	DISTANZSTÜCK	DISTANCIAL		1	
6	R17143101A	ANELLO DI TENUTA	SEAL RING	BAGUE D'ÉTANCHÉITÉ	DICHTRING	ANILLO DE RETÉN		1	
7	R90350672B	VITE	SCREW	VIS	SCHRAUBE	TORNILLO		2	
8	R180229002000	CORPO POMPA ACQUA	WATER PUMP BODY	CORPS POMPE EAU	KÖRPER WASSERPUMPE	CUERPO BOMBA AGUA		1	
9	R16313361A	BUSSOLA DI CENTRAGGIO	CENTRING BUSH	DOUILLE DE CENTRAGE	ZENTRIERBUCHSE	CASQUILLO DE CENTRADO		2	
10	R17113061A	ALBERO POMPA ACQUA	WATER PUMP SHAFT	ARBRE POMPE EAU	WASSERPUMPEWELLE	ARBOL BOMBA AGUA		1	
11	R17143091A	CONTROFACCIA	SEAL	ÉTANCHÉITÉ HYDRAULIQUE	HYDRAULIKDICHTUNG	RETÉN HIDRÁULICO		1	
12	R17143081A	TENUTA MECCANICA	MECHANICAL SEAL	TENUE MÉCANIQUE	MECHANISCHE DICHTUNG	JUNTA MECÁNICA		1	
13	R180229003000	GIRANTE POMPA ACQUA	WATER PUMP FAN	COURONNE POMPE EAU	LÄUFERRAD DER WASSERPUMPE	ROTOR BOMBA AGUA		1	
14	R92050158E	RONDELLA DI TENUTA	STOP WASHER	RONDELLE D'ÉTANCHÉITÉ	DICHTUNGSRING	ARANDELA DE RETÉN		1	
15	R91851029G	DADO CIECO	CAP NUT	ECROU BORGNE	BILNDE MUTTER	TUERCA CIEGA		1	
16	R92850029M	ANELLO DI TENUTA	SEAL RING	BAGUE D'ÉTANCHÉITÉ	DICHTRING	ANILLO DE RETÉN		1	
17	R90750722B	VITE	SCREW	VIS	SCHRAUBE	TORNILLO		2	
18	R180201011000	COPERCHIO POMPA ACQUA	WATER PUMP COVER	COUVERCLE POMPE À EAU	WASSERPUMPENDECKEL	TAPA BOMBA AGUA		1	
19	R92850039M	ANELLO DI TENUTA	SEAL RING	BAGUE D'ÉTANCHÉITÉ	DICHTRING	ANILLO DE RETÉN		1	
20	R180229004000	GOMITO ENTRATA ACQUA	WATER ELBOW INLET	COUDE ENTRÉE EAU	KNIESTÜCK WASSEREINLAUF	CODO ENTRADA AGUA		1	
21	R17113031A	PIASTRINO	PLATE	PLAQUETTE	PLÄTTCHEN	LÁMINA		2	
22	R90750652B	VITE	SCREW	VIS	SCHRAUBE	TORNILLO		2	
23	R90750622B	VITE	SCREW	VIS	SCHRAUBE	TORNILLO		1	
24	R17143231A	RONDELLA DI TENUTA	STOP WASHER	RONDELLE D'ÉTANCHÉITÉ	DICHTUNGSRING	ARANDELA DE RETÉN		1	

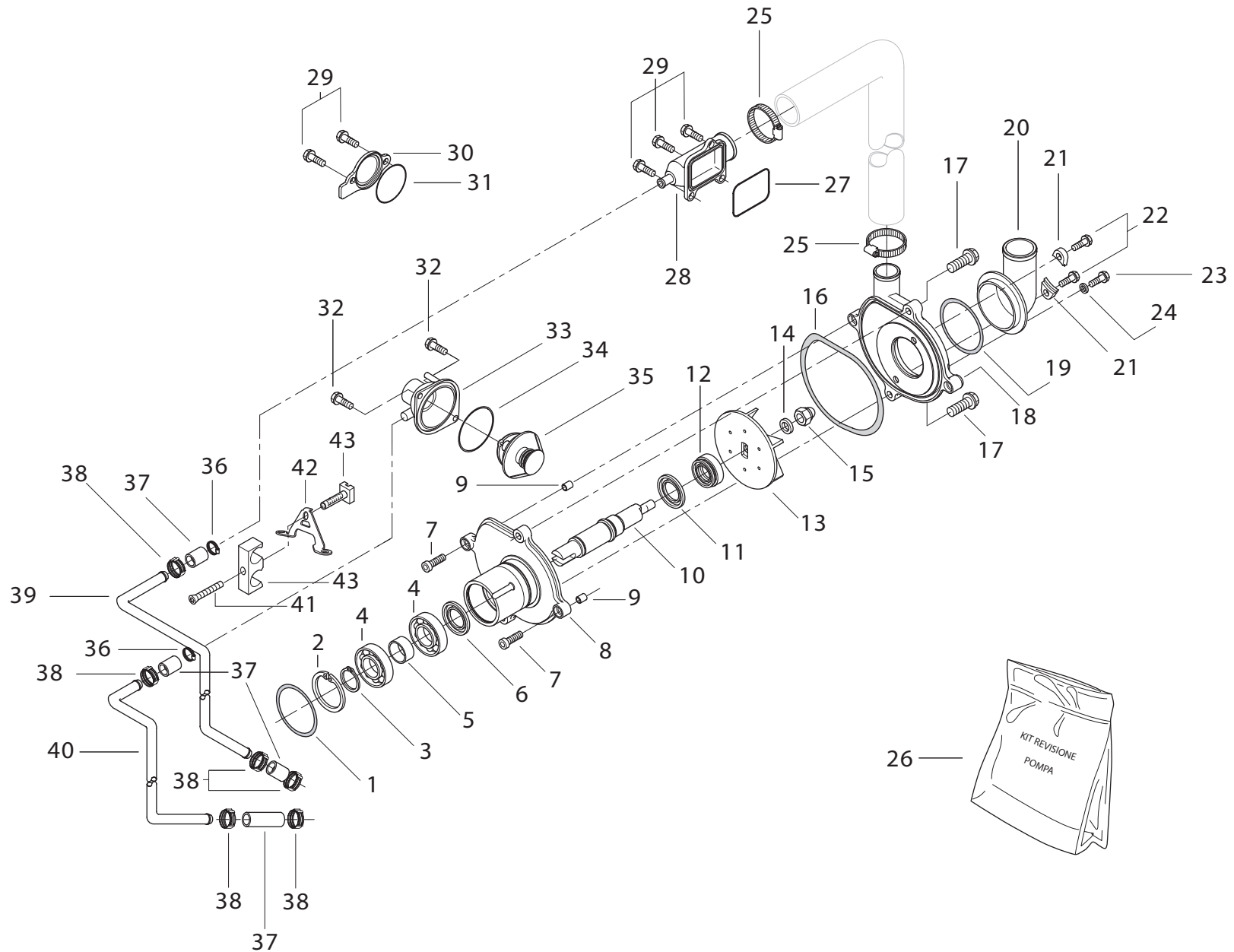

POS. NO. N. INDEX POS.	N. CODICE CODE NO. Nr. CODE ATRIKEL Nr. CODICO Nr.	DESCRIZIONE	DESCRIPTION	DESIGNATION	BEZEICHNUNG	DENOMINACION	NOTE NOTES NOTES MARKE NOTAS	Q.TA' Q.TY Q.TE M.GE C.AD	
25	R95350277B	FASCETTA A VITE	SCREW HOSE CLAMP	COLLIER À VISSER	SCHRAUBENSHELLE	ABRAZADERA A TORNILLO		2	
26	R300000184000	KIT REVISIONE POMPA	KIT REVISION PUMP	KIT RÉVISION POMPE	KIT NEUAUSGABE PUMPE	KIT REVISIÓN BOMBA		1	
27	R92850059M	GUARNIZIONE OR	O-RING	JOINT D'ÉTANCHÉITÉ	DICHTUNG OR	JUNTA OR		1	
28	R180428004000	COLLETTORE ACQUA	WATER MANIFOLD	COLLECTEUR EAU	WASSERKRÜMMER	COLECTOR AGUA		1	
29	R90750672B	VITE	SCREW	VIS	SCHRAUBE	TORNILLO		5	
30	R3000010120CE	COPERCHIO ACQUA	WATER COVER	COUVERCLE EAU	WASSERDECKEL	TAPA AGUA		1	
31	R92850249M	ANELLO DI TENUTA	SEAL RING	BAGUE D'ÉTANCHÉITÉ	DICHTRING	ANILLO DE RETÉN		1	
32	R90750692B	VITE	SCREW	VIS	SCHRAUBE	TORNILLO		2	
33	R310028005000	TAZZA TERMOSTATO	THERMOSTAT BELLEVILLE	BOL THERMOSTAT	THERMOSTATTELLER	TAZA TERMÓSTATO		1	
34	R92850069M	ANELLO DI TENUTA	SEAL RING	BAGUE D'ÉTANCHÉITÉ	DICHTRING	ANILLO DE RÉTEN		1	
35	R17113141A	TERMOSTATO	THERMOSTAT	THERMOSTAT	THERMOSTAT	TERMÓSTATO		1	
36	R95350017B	FASCETTA A VITE	SCREW HOSE CLAMP	COLLIER À VISSER	SCHRAUBENSHELLE	ABRAZADERA A TORNILLO		2	
37	R180128003000	TUBO ACQUA	WATER TUBE	TUBE EAU	WASSERROHR	TUBO AGUA		4	
38	R95150537B	FASCETTA	CLAMP	COLLIER	SHELLE	ABRAZADERA		6	
39	R3100280020CM	TUBO INGRESSO SCAMBIATORE	EXCHANGER OUTLET TUBE	TUBE SORTIE ECHANGEUR	AUSGANGSSCHLAUCH AUSTAUSCHER	TUBO DE ENCHUFE DEL CAMBIADOR		1	
40	R3100280010CM	TUBO USCITA SCAMBIATORE	EXCHANGER INLET TUBE	TUBE ENRTEE ECHANGEUR	EINGANGSSCHLAUCH AUSTAUSCHER	TUBO DE LA ENTRADA DEL CAMBIADOR		1	
41	R90650482B	VITE	SCREW	VIS	SCHRAUBE	TORNILLO		1	
42	R310057135000	PIASTRINO	PLATE	PLAQUETTE	PLÄTTCHEN	PLACA		1	
43	R310068100000	FERMATUBO DOPPIO	DOUBLE PIPE STOP	ARRET TUBE DOUBLE	SCHLAUCHHALTERUNG DOPPELTES	PASADOR TUBO DOBLE		1	

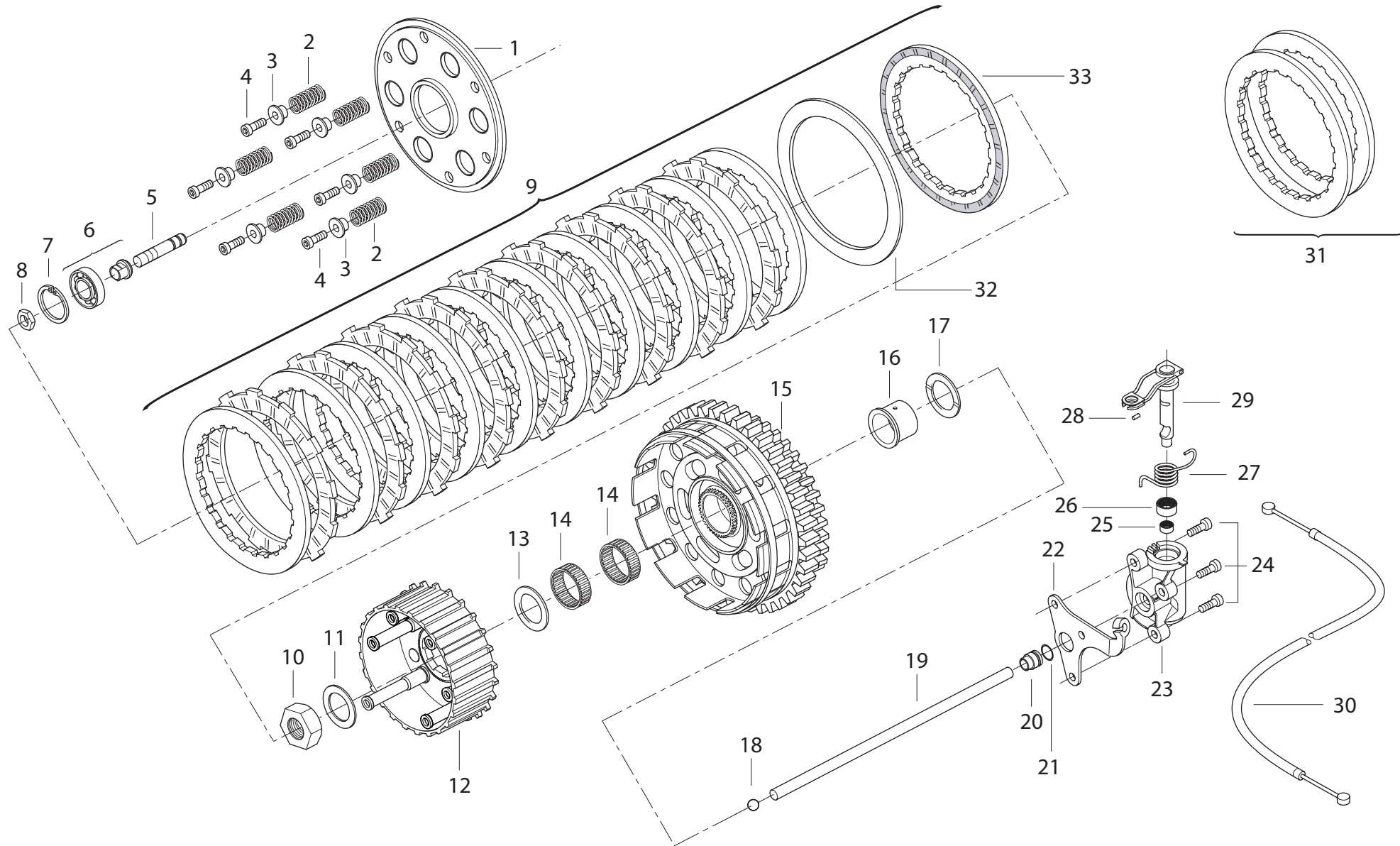

POS. NO. N. INDEX POS.	N. CODICE CODE NO. Nr. CODE ATRIKEL Nr. CODICO Nr.	DESCRIZIONE	DESCRIPTION	DESIGNATION	BEZEICHNUNG	DENOMINACION	NOTE NOTES NOTES MARKE NOTAS	Q.TA' Q.TY Q.TE M.GE C.AD	
1	R180200147001	SPINGIDISCO	PRESSURE PLATE	POUSSE-DISQUE	SCHEIBENDRÜCKER	EMPUJA-DISCO		1	
2	R16043911A	MOLLA FRIZIONE	CLUTCH SPRING	RESSORT EMBRAYAGE	KUPPLUNGSFEDER	MUELLE EMBRAGUE		6	
3	R180124018000	SCODELLINO	RETAINER	CUVETTE	TELLER	PLATILLO		6	
4	R180124025000	VITE	SCREW	VIS	SCHRAUBE	TORNILLO		6	
5	R180224014000	PERNO SPINGIDISCO	PRESSURE PLATE PIN	GOUJON	BOLZEN	PERNO EMPUJA-DISCO		1	
6	R180200146000	CUSCINETTO CON BUSSOLA	BEARING WITH BUSH	ROULEMENT EN DOUILLE	LAGER MIT BUCHSE	COJINETE CON CASQUILLO		1	
7	R92550350D	ANELLO ELASTICO	SNAP RING	BAGUE ÉLASTIQUE	SPRENGRING	SEAGER		1	
8	R16044271A	DADO	NUT	ECROU	MUTTER	TUERCA		1	
9	R300000141000	SERIE DISCHI FRIZIONE	CLUTCH PLATES SET	SÉRIE DE DISQUES EMBRAYAGE	KUPPLUNGSSCHEIBENSATZ	SERIE DISCOS EMBRAGUE		1	
10	R180224015000	DADO ESAGONALE	HEXAGON NUT	ECROU HEXAGONAL	SECHSKANTMUTTER	TUERCA HEXAGONAL		1	
11	R16043811A	MOLLA A TAZZA	SPRING WASHER	BELLEVILLE	TELLERFEDER	ARANDELA DE MUELLE		1	
12	R300024023000	TAMBURO FRIZIONE	CLUTCH DRUM	TAMBOUR EMBRAYAGE	KUPPLUNGSTROMMEL	TAMBOR EMBRAGUE		1	
13	R180224011000	RASAMENTO	SHIM	ROSETTE DE BUTÉE ÉPAISSEUR	DISTANZSCHEIBE STÄRKE	ARANDELA DE ESPESORACIÓN		1	
14	R180220000000	GABBIA A RULLINI	NEEDLE BEARING	BOÎTE À AIGUILLES	NADELKÄFIG	JAULA DE RODILLOS		2	
15	R180200139001	CAMPANA FRIZIONE	CLUTCH HOUSING	CLOCHE EMBRAYAGE	KUPPLUNGSGLOCKE	CAMPANA EMBRAGUE		1	
16	R180224009000	DISTANZIALE	SPACER	ENTRETOISE	DISTANZSTÜCK	DISTANCIAL		1	
17	R180224008000	RASAMENTO	SHIM	ROSETTE DE BUTÉE ÉPAISSEUR	DISTANZSCHEIBE STÄRKE	ARANDELA DE ESPESORACIÓN		1	
18	R92751259C	SFERA	BALL	BILLE	KUGEL	ESFERA		1	
19	R180224016000	ASTA COMANDO FRIZIONE	CLUTCH CONTROL ROD	TIGE DE COMMANDE EMBRAYAGE	KUPPLUNGSSTEUERUNGSSTAB	VARILLA MANDO EMBRAGUE		1	
20	R16014231A	BUSSOLA	BUSH	DOUILLE	BUCHSE	CASQUILLO		1	
21	R92850219M	GUARNIZIONE OR	O-RING	JOINT D'ÉTANCHÉITÉ	DICHTUNG OR	JUNTA OR		1	
22	R180224033000	PIASTRINO	PLATE	PLAQUETTE	PLÄTTCHEN	LÁMINA		1	
23	R180224104000	COMANDO FRIZIONE	CLUTCH CONTROL	COMMANDE EMBRAYAGE	KUPPLUNGSSTEUERUNG	ACCINAMENTO EMBRAGUE		1	
24	R90250672B	VITE	SCREW	VIS	SCHRAUBE	TORNILLO		3	

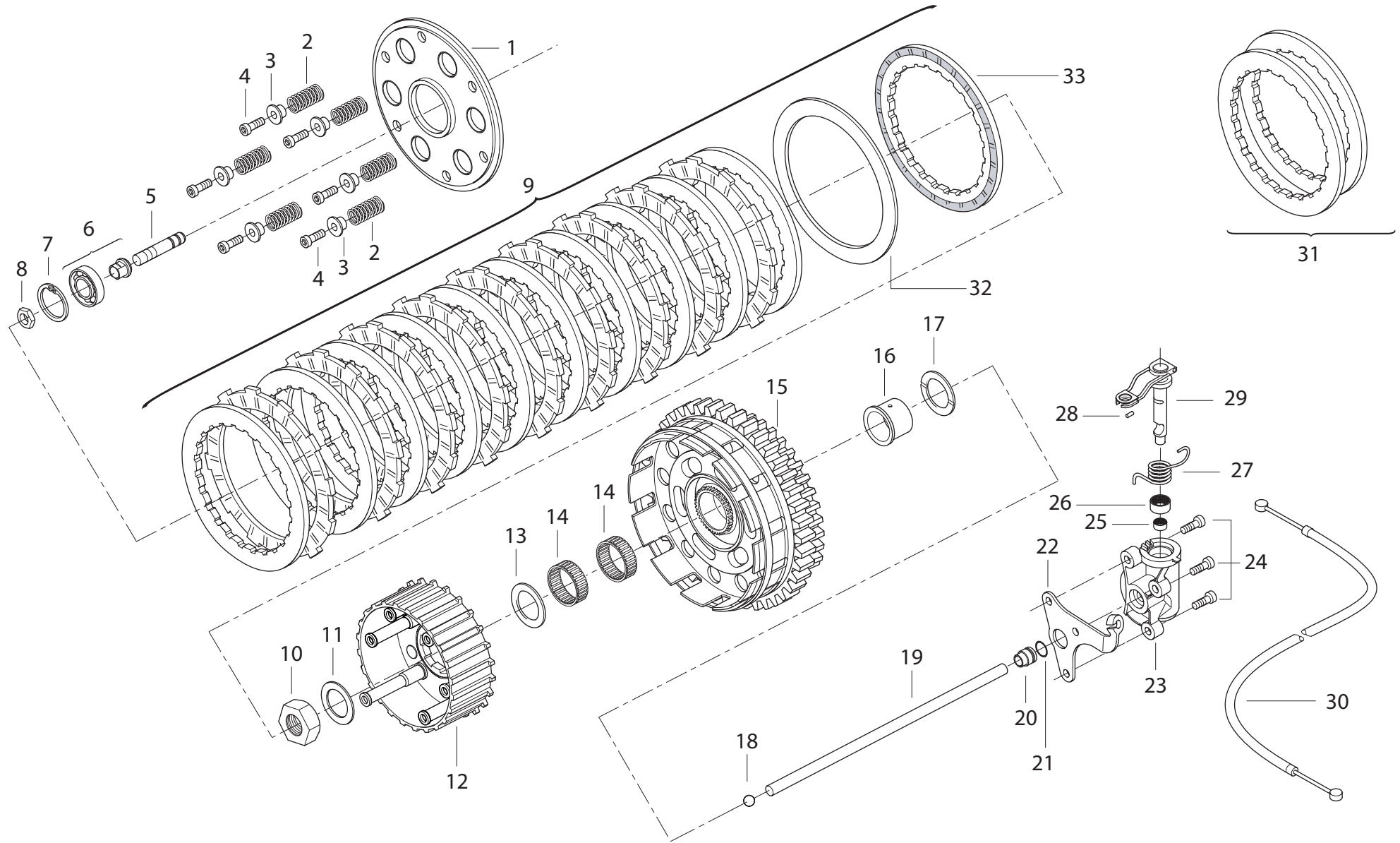

POS. NO. N. INDEX POS.	N. CODICE CODE NO. Nr. CODE ATRIKEL Nr. CODICO Nr.	DESCRIZIONE	DESCRIPTION	DESIGNATION	BEZEICHNUNG	DENOMINACION	NOTE NOTES NOTES MARKE NOTAS	Q.TA' Q.TY Q.TE M.GE C.AD	
25	R16044311A	GABBIA A RULLINI	NEEDLE BEARING	BOÎTE À AIGUILLES	NADELKÄFIG	JAULA DE RODILLOS		1	
26	R16044301A	GABBIA A RULLINI	NEEDLE BEARING	BOÎTE À AIGUILLES	NADELKÄFIG	JAULA DE RODILLOS		1	
27	R180224031000	MOLLA	SPRING	RESSORT	FEDER	MUELLE		1	
28	R92750449C	SPINA	PIN	GOUPILLE	STIFT	PASADOR		1	
29	R180224038000	COMANDO FRIZIONE	CLUTCH CONTROL	COMMANDE EMBRAYAGE	KUPPLUNGSSTEUERUNG	ACCINAMENTO EMBRAGUE		1	
30	R310065009000	CAVO FRIZIONE	CABLE ASSY CLUTCH	CÂBLE EMBRAYAGE	KUPPLUNGSKABEL	CABLE EMBRAGUE		1	
31	R180200145000	KIT DISCHI DI REGOLAZIONE	SET CLUTCH REGULATION PLATES	SÉRIE DE DISQUES RÉGLEMENT D'EMBAYAGE	SCHEIBENSATZ	SERIE DISCOS DE LA REGULACIÓN		1	
32	R180224042000	MOLLA A TAZZA	SPRING WASHER	BELLEVILLE	TELLERFEDER	ARANDELA DE MUELLE		1	
33	R180224039000	DISCO FRONTALE GUARNITO	DISC	DISQUE	HEIBE	DISCO		1	

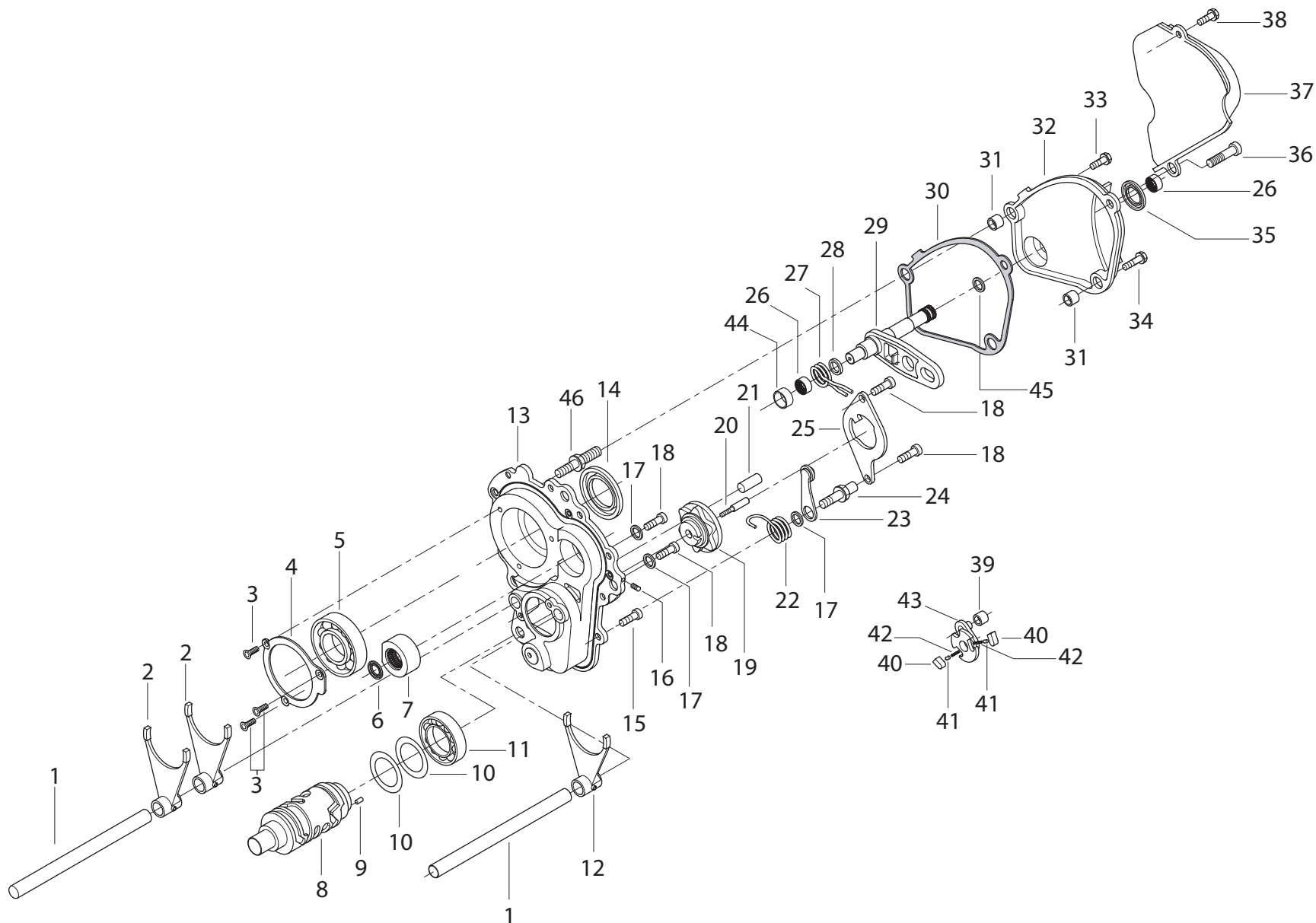

POS. NO. N. INDEX POS.	N. CODICE CODE NO. Nr. CODE ATRIKEL Nr. CODICO Nr.	DESCRIZIONE	DESCRIPTION	DESIGNATION	BEZEICHNUNG	DENOMINACION	NOTE NOTES NOTES MARKE NOTAS	Q.TA' Q.TY Q.TE M.GE C.AD	
1	R16313201A	PERNO	PIN	PIVOT	ZAPFEN	PERNO		2	
2	R16313721A	FORCELLA INNESTO MARCE 1 ^a /4 ^a -2 ^a /3 ^a	1st, 4th-2nd, 3rd GEAR SELECTOR FORK	FOURCHE ENGRÈNEMENT 1ère, 4ème-2ème, 3ème VITESSE	EINLEGEGABEL FÜR 1.,4.,-2.,3. GANG	HORQUILLA EMBRAGUE MARCHAS 1°, 4°-2°, 3°		2	
3	R90650490B	VITE	SCREW	VIS	SCHRAUBE	TORNILLO		3	
4	R16313031A	PIASTRINO	PLATE	PLAQUETTE	PLÄTTCHEN	LÁMINA		1	
5	R180202022000	CUSCINETTO	BEARING	ROULEMENT	LAGER	COJINETE		1	
6	R16343991A	ANELLO DI TENUTA	SEAL RING	BAGUE D'ÉTANCHÉITÉ	DICHTRING	ANILLO DE RETÉN		1	
7	R16344081A	CUSCINETTO	BEARING	ROULEMENT	LAGER	COJINETE		1	
8	R16314071A	DESMODROMICO	SHIFT CAM	DESMODROMIQUE	VERSCHIEBENOCKE	DESMO		1	
9	R92750649C	SPINA	PIN	GOUPILLE	STIFT	PASADOR		1	
10	R16343561A	RASAMENTO	SHIM	ROSETTE DE BUTÉE ÉPAISSEUR	DISTANZSCHEIBE STÄRKE	ARANDELA DE ESPESORACIÓN		2	
11	R16343531A	CUSCINETTO	BEARING	ROULEMENT	LAGER	COJINETE		1	
12	R16313191A	FORCELLA INNESTO MARCE 5 ^a /6 ^a	5TH, 6TH GEAR SELECTOR FORK	FOURCHE ENGRÈNEMENT 5ème, 6ème VITESSE	EINLEGEGABEL FÜR 5., 6. GANG	HORQUILLA EMBRAGUE 5°, 6°		1	
13	R180201007000	FLANGIA CAMBIO	GEAR FLANGE	BRIDE CHANGEMENT	GETRIEBEFLANSCH	ARANDELA CAMBIO		1	
14	R16343521A	ANELLO DI TENUTA	SEAL RING	BAGUE D'ÉTANCHÉITÉ	DICHTRING	ANILLO DE RÉTEN		1	
15	R90351252B	VITE	SCREW	VIS	SCHRAUBE	TORNILLO		1	
16	R14043141A	TAPPO FILETTATO	THREADED CAP	BOUCHON FILETÉE	GEWINDEVERSCLUß	TAPÓN FILETEADO		1	
17	R16313211A	RONDELLA	WASHER	RONDELLE	UNTERLEGSCHIBE	ARANDELA		3	
18	R90250642B	VITE	SCREW	VIS	SCHRAUBE	TORNILLO		4	
19	R16313931A	TAMBURO CAMBIO COMPLETO	COMPLETE GEARBOX DRUM	TAMBOUR COMPLET BOÎTE DE VITESSES	SCHALTROMMEL KOMPLETT	TAMBOR CAMBIO COMPLETO		1	
20	R16313081A	PERNO FISSAGGIO TAMBURO	DRUM FIXING PIN	PIVOT FIXATION TAMBOUR	BEFESTIGUNGSBOLZEN TROMMEL	PERNO FIJACIÓN TAMBOR		1	
21	R16313121A	PIOLO	PIN	PIVOT	STIFT	ESPINA		1	
22	R16313681A	MOLLA	SPRING	RESSORT	FEDER	MUELLE		1	
23	R16323221A	SALTARELLO FISSA MARCE	GEAR STOPPER	CLIQUET FIXE-VITESSES	FALLKLINKEN	TRINQUETE FIJA MARCHAS		1	
24	R16313671A	PERNO FILETTATO	THREADED PIN	PIVOT FILETÉE	GEWINDEZAPFEN	PERNO FILETEADO		1	

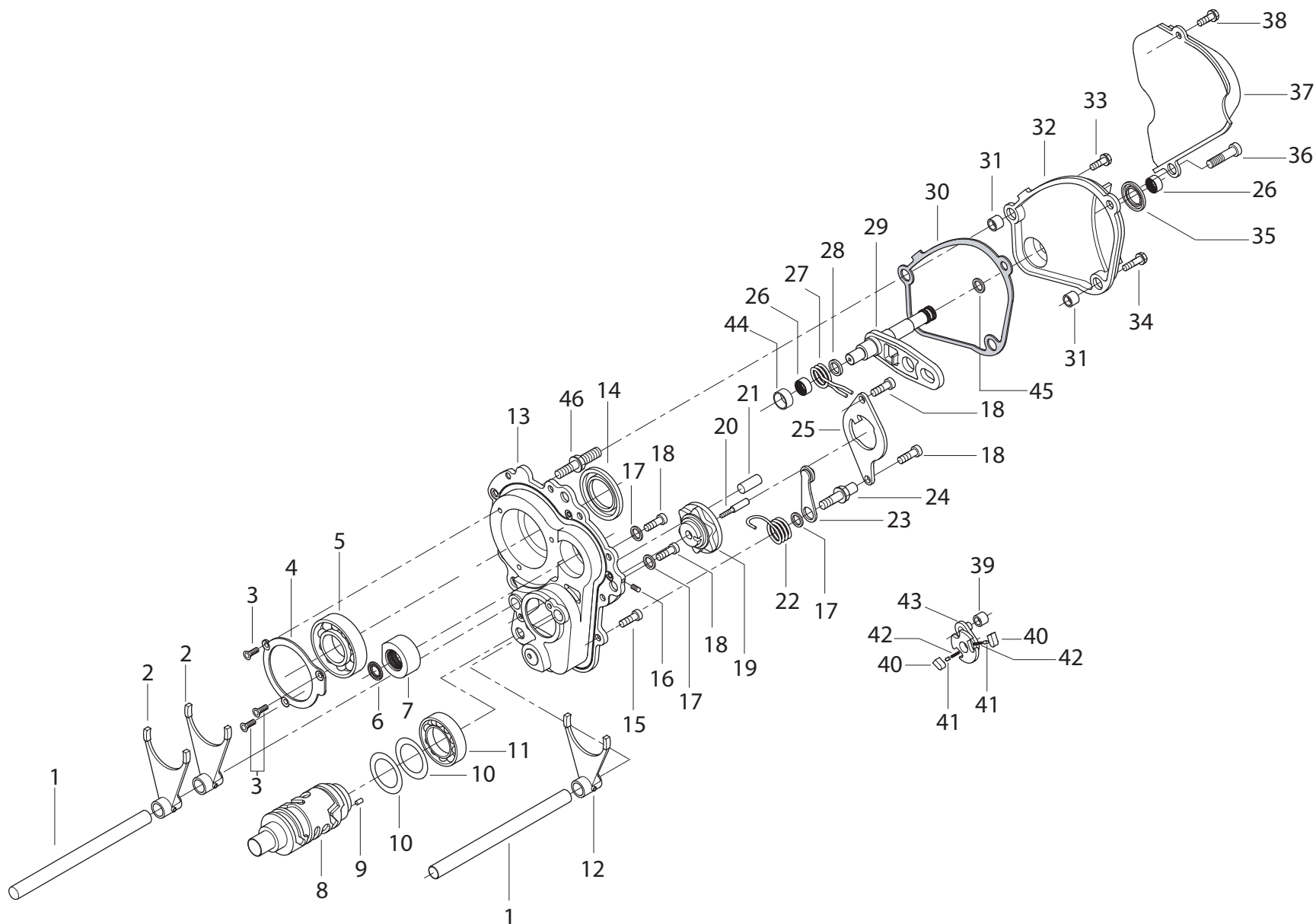

POS. NO. N. INDEX POS.	N. CODICE CODE NO. Nr. CODE ATRIKEL Nr. CODICO Nr.	DESCRIZIONE	DESCRIPTION	DESIGNATION	BEZEICHNUNG	DENOMINACION	NOTE NOTES NOTES MARKE NOTAS	Q.TA' Q.TY Q.TE M.GE C.AD	
25	R16313941A	FLANGIA	FLANGE	BRIDE	FLANSCH	BRIDA		1	
26	R180224037000	DISTANZIALE	SPACER	ENTRETOISE	DISTANZSTÜCK	DISTANCIAL		2	
27	R16313321A	MOLLA	SPRING	RESSORT	FEDER	MUELLE		1	
28	R16313461A	RONDELLA	WASHER	RONDELLE	UNTERLEGSCHIEBE	ARANDELA		1	
29	R180226002000	PERNO	PIN	PIVOT	ZAPFEN	PERNO		1	
30	R16313351A	GUARNIZIONE COPERCHIO	COVER GASKET	GARNITURE COUVERCLE	DECKELDICHUNG	JUNTA TAPA		1	
31	R16313361A	BUSSOLA	BUSH	DOUILLE	BUCHSE	CASQUILLO		2	
32	R180201008000	COPERCHIO COMANDO CAMBIO	GEAR CONTROL COVER	COUVERCLE COMMANDE CHANGEMENT	DECKEL GETRIEBESCHALTUNG	TAPA MANDO CAMBIO		1	
33	R90750652B	VITE	SCREW	VIS	SCHRAUBE	TORNILLO		1	
34	R90750672B	VITE	SCREW	VIS	SCHRAUBE	TORNILLO		1	
35	R16343611A	ANELLO DI TENUTA	SEAL RING	BAGUE D'ÉTANCHÉITÉ	DICHTRING	ANILLO DE RÉTEN		1	
36	R90351332B	VITE	SCREW	VIS	SCHRAUBE	CASQUILLO		1	
37	R180201009000	COPERCHIO PIGNONE	SPROCKET COVER	COUVERCLE PIGNON	DECKELRITZEL	TAPA PIÑÓN		1	
38	R90750692B	VITE	SCREW	VIS	SCHRAUBE	TORNILLO		1	
39	R16313171A	BOCCOLA	BUSH	DOUILLE	BUCHSE	CASQUILLO		1	
40	R16313131A	SALTARELLO ROCCHETTO	SPROCKET RATCHET	SAUTERELLE PIGNON	SPERRNOCKEN FÜR KLEINRAD	TRINQUETE PIÑÓN		2	
41	R16313141A	PIOLO	PIN	PIVOT	STIFT	ESPINA		2	
42	R16313151A	MOLLA	SPRING	RESSORT	FEDER	MUELLE		2	
43	R16323981A	ROCCHETTO DESMODROMICO	SHIFT CAM RATCHET	PIGNON DESMODROMIQUE	KLEINRAD VERSCHIEBENOCKE	ROQUETE DESMODROMICO		1	
44	R16343481A	ASTUCCIO A RULLINI	NEEDLE BEARING	ROULEMENT À ROULEAUX	NADELLAGER	COJINETE DE AGUJAS		1	
45	R180204015000	RASAMENTO	SHIM	ROSETTE DE BUTÉE ÉPAISSEUR	DISTANZSCHEIBE STÄRKE	ARANDELA DE ESPESORACIÓN		1	
46	R90752191A	VITE SPECIALE	SPECIAL SCREW	VIS SPÉCIALE	SPEZIALSCHRAUBE	TORNILLO ESPECIAL		1	

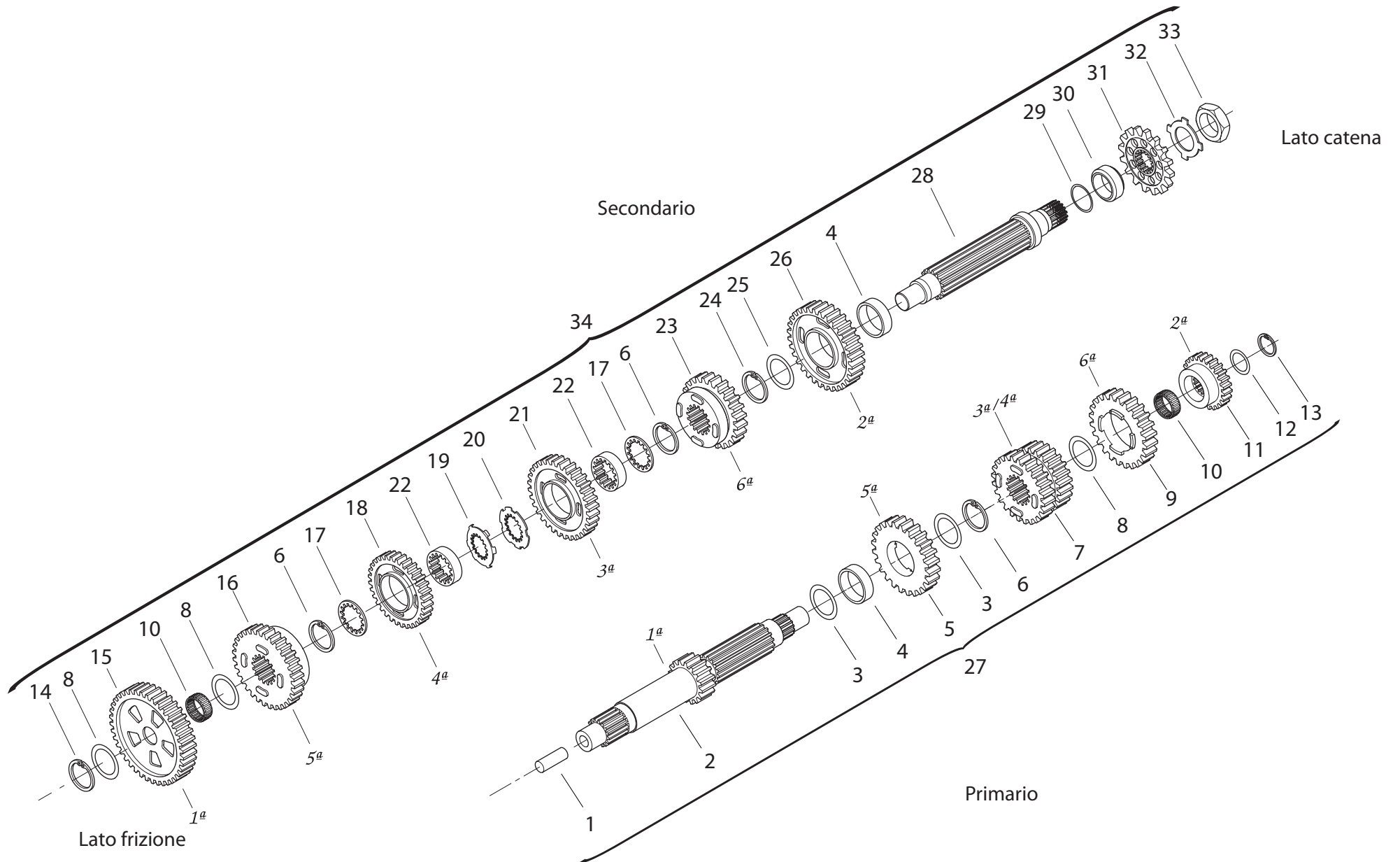

POS. NO. N. INDEX POS.	N. CODICE CODE NO. Nr. CODE ATRIKEL Nr. CODICO Nr.	DESCRIZIONE	DESCRIPTION	DESIGNATION	BEZEICHNUNG	DENOMINACION	NOTE NOTES NOTES MARKE NOTAS	Q.TA' Q.TY Q.TE M.GE C.AD	
1	R16114161A	BOCCOLA	BUSH	DOUILLE	BUCHSE	CASQUILLO		1	
2	R180224006000	ALBERO PRIMARIO Z14	MAIN SHAFT	ARBRE PRIMAIRE	HAUPTWELLE	ARBOL PRIMARIO		1	
3	R16113081A	RASAMENTO	SHIM	ROSETTE DE BUTÉE ÉPAISSEUR	DISTANZSCHEIBE STÄRKE	ARANDELA DE ESPESORACIÓN		2	
4	R300025102000	GABBIA A RULLINI	NEEDLE BEARING	BOÎTE À AIGUILLES	NADELKÄFIG	JAULA DE RODILLOS		2	
5	R16113051A	INGRANAGGIO CONDUTTORE 5° Z24	DRIVING GEAR 5th	ENGRENAGE CONDUCTEUR 5ème	ANTRIEBSZAHNRAD 5.	ENGRANAJE ACCIONADOR 5°		1	
6	R92452300D	ANELLO ELASTICO	SNAP RING	BAGUE ÉLASTIQUE	SPRENGRING	SEAGER		3	
7	R16113551A	INGRANAGGIO CONDUTTORE 3°/4°	DRIVING GEAR 3rd/4th	ENGRENAGE CONDUCTEUR 3ème/4ème	ANTRIEBSZAHNRAD 3./4.	ENGRANAJE ACCIONADOR 3°/4°		1	
8	R16113091A	RASAMENTO	SHIM	ROSETTE DE BUTÉE ÉPAISSEUR	DISTANZSCHEIBE STÄRKE	ARANDELA DE ESPESORACIÓN		3	
9	R310025007000	INGRANAGGIO CONDUTTORE 6° Z25	DRIVING GEAR 6th	ENGRENAGE CONDUCTEUR 6ème	ANTRIEBSZAHNRAD 6.	ENGRANAJE ACCIONADOR 6°		1	
10	R16143331A	GABBIA A RULLINI	NEEDLE BEARING	BOÎTE À AIGUILLES	NADELKÄFIG	JAULA DE RODILLOS		2	
11	R16113541A	INGRANAGGIO CONDUTTORE 2° Z18	DRIVING GEAR 2nd	ENGRENAGE CONDUCTEUR 2ème	ANTRIEBSZAHNRAD 2.	ENGRANAJE ACCIONADOR 2°		1	
12	R16113191A	RASAMENTO	SHIM	ROSETTE DE BUTÉE ÉPAISSEUR	DISTANZSCHEIBE STÄRKE	ARANDELA DE ESPESORACIÓN		1	
13	R92452180D	ANELLO ELASTICO	SNAP RING	BAGUE ÉLASTIQUE	SPRENGRING	SEAGER		1	
14	R92051250D	ANELLO ELASTICO	SNAP RING	BAGUE ÉLASTIQUE	SPRENGRING	SEAGER		1	
15	R180225009001	INGRANAGGIO CONDOTTO 1° Z39	DRIVEN GEAR 1st	ENGRENAGE ENTRAÎNÉ 1ère	ANGETRIEBENES ZAHNRAD 1.	ENGRANAJE CONDUCCIONADO 1°		1	
16	R300025006000	INGRANAGGIO CONDOTTO 5° Z28	DRIVEN GEAR 5th	ENGRENAGE ENTRAÎNÉ 5ème	ANGETRIEBENES ZAHNRAD 5.	ENGRANAJE CONDUCCIONADO 5°		1	
17	R16113211A	RASAMENTO BROCCIATO	BROACHED THRUST WASHER	RACLEUR BROCHE	RÄUMPASSSCHEIBE	ARANDELA RANURADA		2	
18	R300025105000	INGRANAGGIO CONDOTTO 4° Z30	DRIVEN GEAR 4th	ENGRENAGE ENTRAÎNÉ 4ème	ANGETRIEBENES ZAHNRAD 4.	ENGRANAJE CONDUCCIONADO 4°		1	
19	R300025107000	ANELLO DI FERMO	CHECK RING	BAGUE D' ARRÊT	SICHERUNGSRING	ANILLO DE BLOQUEO		1	
20	R300025106000	RASAMENTO BROCCIATO	BROACHED THRUST WASHER	RACLEUR BROCHE	RÄUMPASSSCHEIBE	CASQUILLO RANURADA		1	
21	R300025103000	INGRANAGGIO CONDOTTO 3° Z32	DRIVEN GEAR 3rd	ENGRENAGE ENTRAÎNÉ 3ème	ANGETRIEBENES ZAHNRAD 3.	ENGRANAJE CONDUCCIONADO 3°		1	
22	R300025104000	BUSSOLA BROCCIATA	BROACHED BUSH	DOUILLE BROCHÉE	RÄUMBUCHSE	ARANDELA RANURADA		2	
23	R300025007000	INGRANAGGIO CONDOTTO 6° Z27	DRIVEN GEAR 6th	ENGRENAGE ENTRAÎNÉ 6ème	ANGETRIEBENES ZAHNRAD 6.	ENGRANAJE CONDUCCIONADO 6°		1	
24	R92051300D	ANELLO ELASTICO	SNAP RING	BAGUE ÉLASTIQUE	SPRENGRING	SEAGER		1	

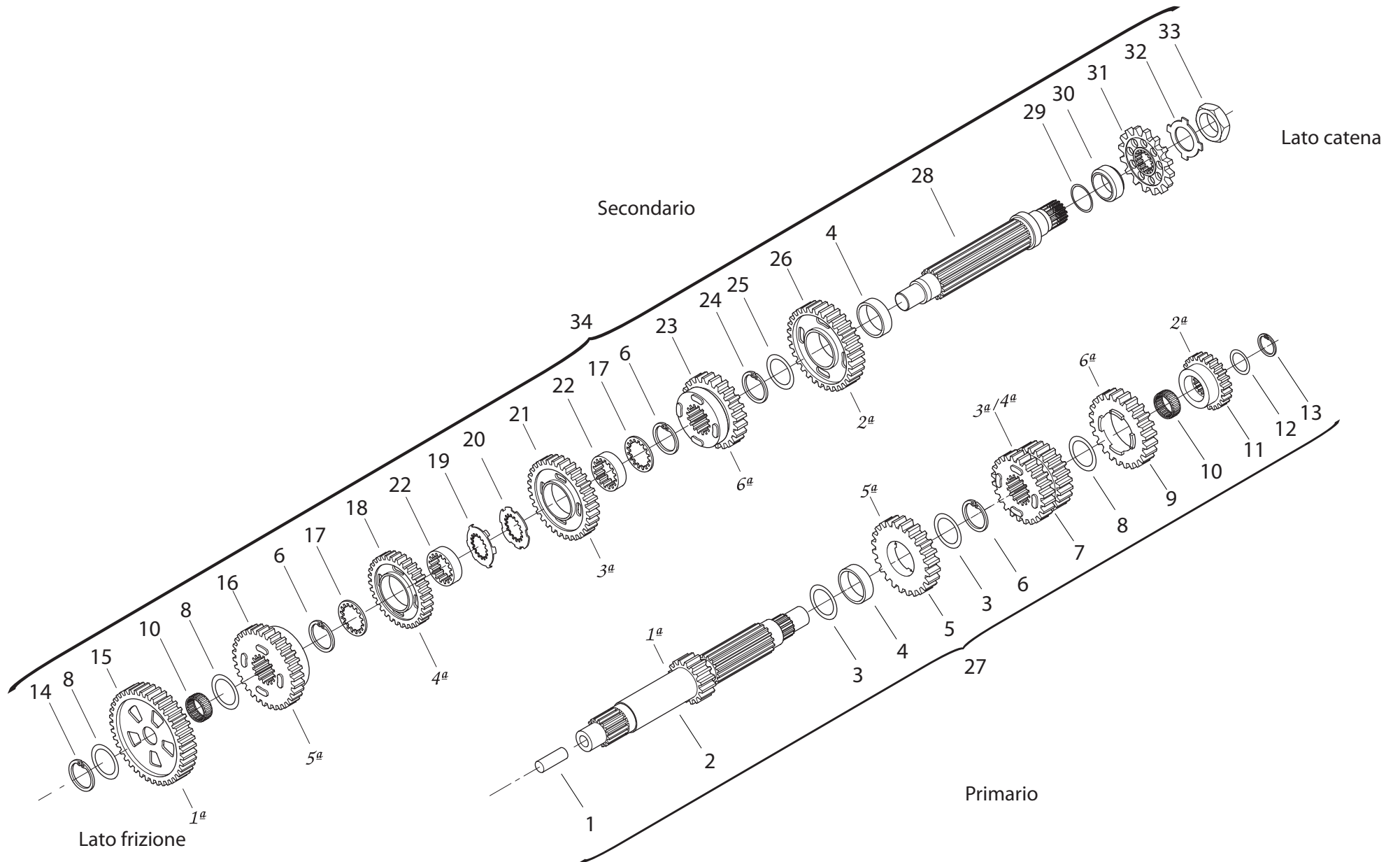

POS. NO. N. INDEX POS.	N. CODICE CODE NO. Nr. CODE ATRIKEL Nr. CODICO Nr.	DESCRIZIONE	DESCRIPTION	DESIGNATION	BEZEICHNUNG	DENOMINACION	NOTE NOTES NOTES MARKE NOTAS	Q.TA' Q.TY Q.TE M.GE C.AD	
25	R16113081A	RASAMENTO	SHIM	ROSETTE DE BUTÉE ÉPAISSEUR	DISTANZSCHEIBE STÄRKE	ARANDELA DE ESPESORACIÓN		1	
26	R180225008000	INGRANAGGIO CONDOTTO 2° Z39	DRIVEN GEAR 2nd	ENGRENAGE ENTRAÎNÉ 2ème	ANGETRIEBENES ZAHNRAD 2.	ENGRANAJE CONDUCIDO 2°		1	
27	R310024005000	ALBERO PRIMARIO COMPLETO	COMPLETE MAIN SHAFT	ARBRE PRIMAIRE COMPLET	KOMPLETTE HAUPTWELLE	ARBOL PRIMARIO COMPLETO		1	
28	R300025101000	ALBERO SECONDARIO	LAY SHAFT	ARBRE SECONDAIRE	VORGELEGEWELLE	ARBOL SECUNDARIO		1	
29	R92850019M	GUARNIZIONE OR	O-RING	JOINT D' ÉTANCHÉITÉ	DICHTUNG OR	JUNTA OR		1	
30	R16113561A	DISTANZIALE PIGNONE	SPROCKET SPACER	ENTRETOISE PIGNON	DISTANZSTÜCK RITZEL	DISTANCIADOR PIÑÓN		1	
31	R75013071A	PIGNONE Z16	SPROCKET Z16	PIGNON Z16	RITZEL Z16	PIÑÓN Z16		1	
32	R16013941A	RONDELLA	WASHER	RONDELLE	UNTERLEGSSCHEIBE	ARANDELA		1	
33	R16113231A	DADO	NUT	ECROU	MUTTER	TUERCA		1	
34	R300025010000	ALBERO SECONDARIO COMPLETO	COMPLETE LAY SHAFT	ARBRE SECONDAIRE COMPLET	KOMPLETTE VORGELEGEWELLE	ARBOL SECUNDARIO COMPLETO		1	

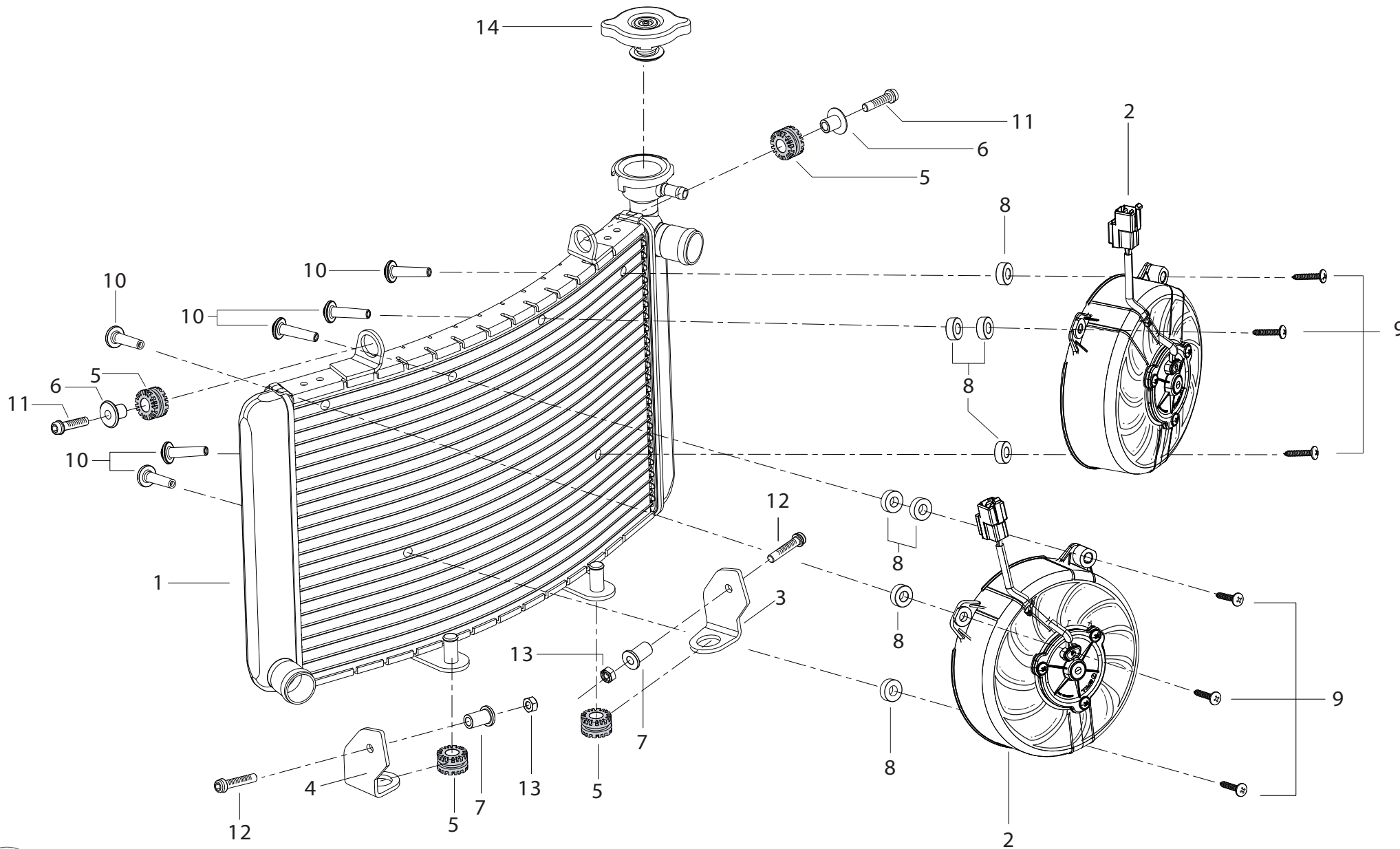

POS. NO. N. INDEX POS.	N. CODICE CODE NO. Nr. CODE ATRIKEL Nr. CODICO Nr.	DESCRIZIONE	DESCRIPTION	DESIGNATION	BEZEICHNUNG	DENOMINACION	NOTE NOTES NOTES MARKE NOTAS	Q.TA' Q.TY Q.TE M.GE C.AD	
1	R310083012000	RADIATORE ACQUA	WATER RADIATOR	RADIATEUR D' EAU	WASSERKUEHLER	RADIATOR AGUA		1	
2	R310083013000	ELETTOVENTOLA	ELECTRIC FAN	ELECTRO-VENTILATEUR	ELEKTROLÜFTERRAD	ELECTROVENTILADOR		2	
3	R310057154000	SUPPORTO DX	R.H. HOLDER	SUPPORT DROITE	HALTERUNG RECHTS	SOPORTE DER.		1	
4	R310057147000	SUPPORTO SX	L.H. HOLDER	SUPPORT GAUCHE	HALTERUNG LINKS	SOPORTE IZQ.		1	
5	R180479181000	GOMMINO	RUBBER PAD	JOINT EN CAOUTCHOUC	GUMMISTÜCK	JUNTA DE GOMA		4	
6	R310079196000	BOCCOLA SUPERIORE	UPPER BUSH	DOUILLE SUPÉRIEURE	OBERER BUCHSE	CASQUILLO SUPERIOR		2	
7	R310079197000	BOCCOLA INFERIORE	LOWER BUSH	DOUILLE INFÉRIEURE	UNTERER BUCHSE	CASQUILLO INFERIOR		2	
8	R300079183000	DISTANZIALE	SPACER	ENTRETOISE	DISTANZSTÜCK	DISTANCIAL		8	
9	R93650069E	VITE	SCREW	VIS	SCHRAUBE	TORNILLO		6	
10	R310052001000	PERNO FISSAGGIO SPECIALE	SPECIAL FIXING PIN	PIVOT FIXATION SPÉCIALE	SPEZIAL BEFESTIGUNG SBOLZEN	PERNO FIJACIÓN ESPECIAL		6	
11	R90750522B	VITE	SCREW	VIS	SCHRAUBE	TORNILLO		2	
12	R90750532B	VITE	SCREW	VIS	SCHRAUBE	TORNILLO		2	
13	R91750032B	DADO	NUT	ECROU	MUTTER	TUERCA		2	
14	R180283008000	TAPPO RADIATORE	RADIATOR CAP	BOUCHON RADIATEUR	VERSCHLUß FÜR KÜHLER	TAPÓN RADIADOR		1	

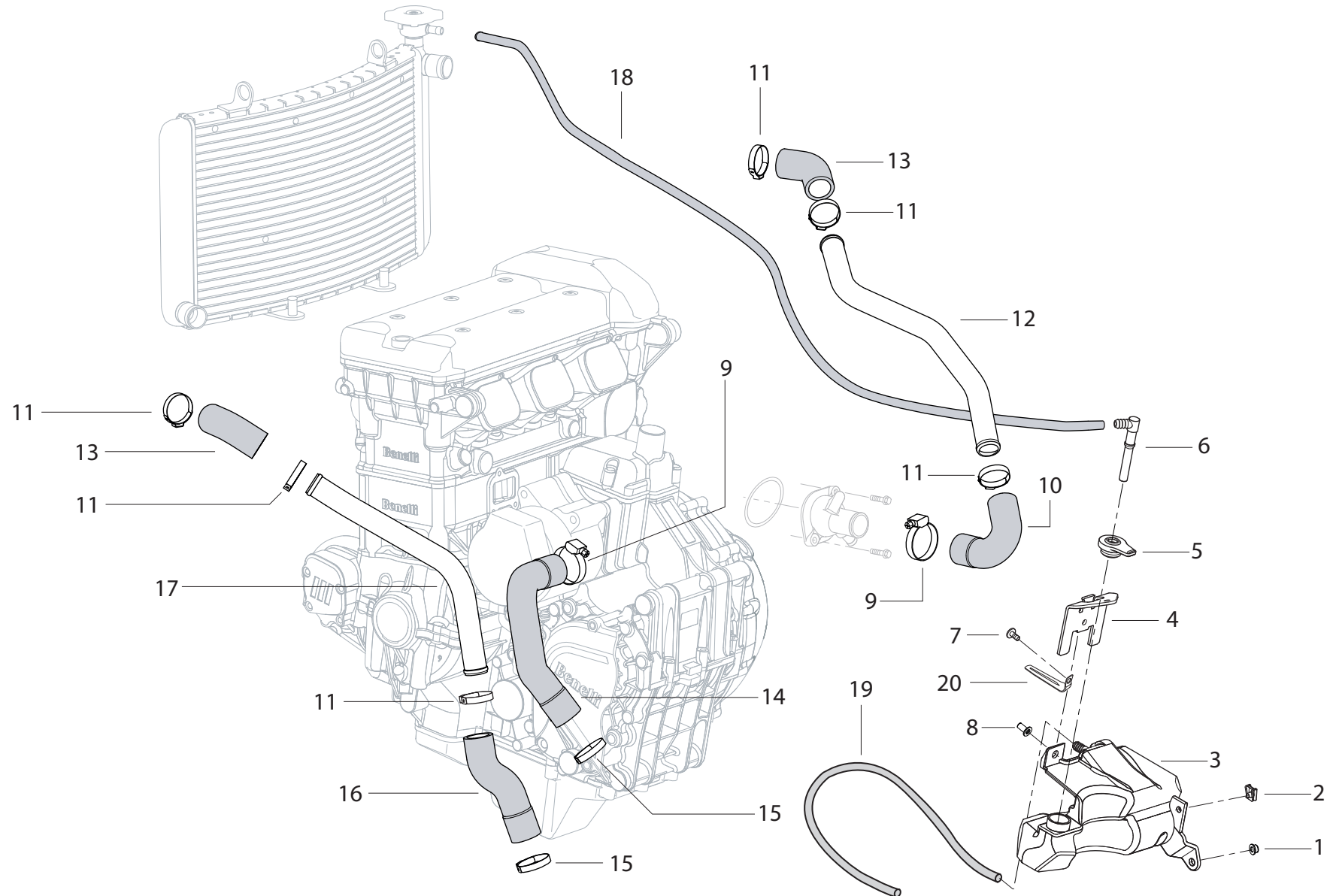

POS. NO. N. INDEX POS.	N. CODICE CODE NO. Nr. CODE ATRIKEL Nr. CODICO Nr.	DESCRIZIONE	DESCRIPTION	DESIGNATION	BEZEICHNUNG	DENOMINACION	NOTE NOTES NOTES MARKE NOTAS	Q.TA' Q.TY Q.TE M.GE C.AD	
1	R180479182000	DISTANZIALE	SPACER	ENTRETOISE	DISTANZSTÜCK	DISTANCIAL		1	
2	R95050082B	CLIP FISSAGGIO RAPIDO	QUIK FASTENING	FIXATION RAPIDE	SCHNELLEBEFESTIGUNG	FIJACIÓN RÁPIDA		1	
3	R300083007000	SERBATOIO ACQUA	WATER TANK	RÉSERVOIR D' EAU	WASSERTANK	DEPÓSITO AGUA		1	
4	R300050198000	PIASTRINO	PLATE	PLAQUETTE	PLÄTTCHEN	PLACA		1	
5	R310083030000	TAPPO SERBATOIO	TANK CAP	BOUCHON DE RÉSERVOIR	TANKVERSCHLUß	TAPÓN DEPÓSITO AGUA		1	
6	R310083031000	TUBO ASPIRAZIONE	INTAKE TUBE	TUBE D'ASPIRATION	ROHR EILNA	TUBO DE ASIRACIÓN		1	
7	R90750182B	VITE	SCREW	VIS	SCHRAUBE	TORNILLO		1	
8	R90750051A	WELL NUT	WELL NUT	WELL NUT	WELL NUT	WELL NUT		1	
9	R95350277B	FASCETTA A VITE	SCREW HOSE CLAMP	COLLIER A VISSER	SCHRAUBENSHELLE	ABRAZADERA A TORNILLO		2	
10	R310083028000	MANICOTTO MOTORE DX	R.H. ENGINE HOSE	MANCHON MOTEUR DROITE	MUFFE MOTOR RECHTE	MANGUETA MOTOR DER.		1	
11	R90753018E	FASCETTA	CLAMP	COLLIER	SHELLE	ABRAZADERA		6	
12	R310083020000	MANICOTTO RADIATORE DX	R.H. COOLER HOSE	MANCHON DROIT RADIATEUR	MUFFE RADIATOR RECHTS	MANGUETA AGUA RADIADOR DER.		1	
13	R310083023000	MANICOTTO RADIATORE	COOLER HOSE	MANCHON RADIATEUR	MUFFE RADIATOR	MANGUETA RADIADOR		2	
14	R300083021000	MANICOTTO	HOSE	MANCHON	MUFFE	MANGUETA		1	
15	R90753028E	FASCETTA	CLAMP	COLLIER	SHELLE	ABRAZADERA		2	
16	R310083027000	MANICOTTO MOTORE SX	L.H. ENGINE HOSE	MANCHON MOTEUR GAUCHE	MUFFE MOTOR LINK	MANGUETA MOTOR IZQ.		1	
17	R310083019000	MANICOTTO RADIATORE SX	L.H. COOLER HOSE	MANCHON GAUCHE RADIATEUR	MUFFE RADIATOR LINKS	MANGUETA AGUA RADIADOR IZQ.		1	
18	R180183001083	MATASSA TUBO cm 83	TUBE SKEIN	ÉCHEVEAU TUBE	STRANG ROHR	MADEJA TUBO		1	
19	R180183001073	MATASSA TUBO cm 73	TUBE SKEIN	ÉCHEVEAU TUBE	STRANG ROHR	MADEJA TUBO		1	
20	R300068105000	FASCETTA GOMMATA	RUBBERIZED CLAMP	COLLIER CHAOUTCHOUTÉ	GUMMIBESCHICHTETES SHELLE	ABRAZADERA ENGOMADA		1	

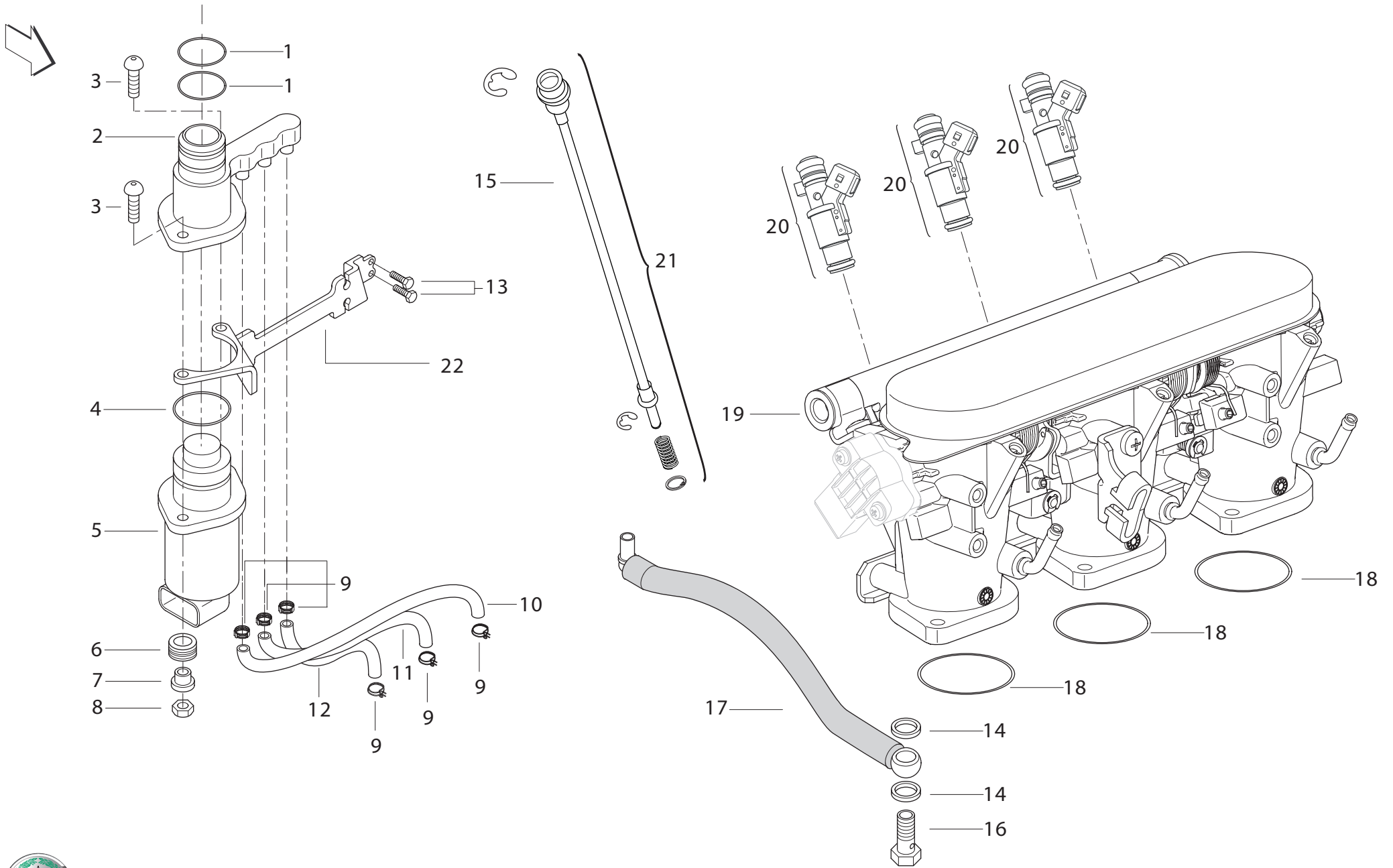

POS. NO. N. INDEX POS.	N. CODICE CODE NO. Nr. CODE ATRIKEL Nr. CODICO Nr.	DESCRIZIONE	DESCRIPTION	DESIGNATION	BEZEICHNUNG	DENOMINACION	NOTE NOTES NOTES MARKE NOTAS	Q.TA' Q.TY Q.TE M.GE C.AD	
1	R92852129M	GUARNIZIONE OR	O-RING	JOINT D' ÉTANCHÉITÉ	DICHTUNG OR	JUNTA OR		2	
2	R18324041A	DISTRIBUTORE	TIMING SYSTEM	DISTRIBUTEUR	VERTEILER	DISTRIBUIDOR		1	
3	R90450448E	VITE	SCREW	VIS	SCHRAUBE	TORNILLO		2	
4	R92850089M	GUARNIZIONE OR	O-RING	JOINT D' ÉTANCHÉITÉ	DICHTUNG OR	JUNTA OR		1	
5	R300077146000	MOTORINO PASSO PASSO	STEPPER MOTOR	MOTEUR PAS-À-PAS	SCHRITTMOTOR	MOTOR PASO PASO		1	
6	R100279118000	GOMMINO ANTIVIBRANTE	VIBRATION DAMPER PAD	JOINT EN CAOUTCHOUC ANTI-VIBRATION	SCHWINGUNGSDÄMPFERGUMMI	JUNTA DE GOMA ANTI-VIBRACIÓN		1	
7	R60110161AY	BOCCOLA	BUSH	DOUILLE	BUCHSE	CASQUILLO		1	
8	R91750022B	DADO	NUT	ECROU	MUTTER	TUERCA		1	
9	R180184001000	FASCETTA CLICK	CLAMP	COLLIER	SHELLE	ABRAZADERA		6	
10	R180190111000	TUBO ARIA MINIMO 3	3 MINIMUM AIR PIPE	TUBE AIR MINI 3	LUFTSCHLAUCH MINIMUM 3	TUBO AIRE MÍNIMO 3		1	
11	R180190110000	TUBO ARIA MINIMO 2	2 MINIMUM AIR PIPE	TUBE AIR MINI 2	LUFTSCHLAUCH MINIMUM 2	TUBO AIRE MÍNIMO 2		1	
12	R180190109000	TUBO ARIA MINIMO 1	1 MINIMUM AIR PIPE	TUBE AIR MINI 1	LUFTSCHLAUCH MINIMUM 1	TUBO AIRE MÍNIMO 1		1	
13	R90750642B	VITE	SCREW	VIS	SCHRAUBE	TORNILLO		2	
14	R18213181A	RONDELLA	WASHER	RONDELLE	UNTERLEGSCHIEBE	ARANDELA		2	
15	R300090138000	CAVO REGOLAZIONE	CABLE FOR ADJUSTMENT	CÂBLE POUR LE RÉGLAGE	KABEL FÜR EINSTELLUNG	CABLE PARA AJUSTE		1	
16	R18343761A	RACCORDO	UNION	RACCORD	ANSCHLUß	EMPALME		1	
17	R180290109000	TUBO MANDATA BENZINA	FUEL DELIVERY PIPE	TUBE REFOULEMENT ESSENCE	BENZINZUFUHRSCHLAUCH	TUBO ENVÍO GASOLINA		1	
18	R92850059M	GUARNIZIONE OR	O-RING	JOINT D' ÉTANCHÉITÉ	DICHTUNG OR	JUNTA OR		3	
19	R18323681A	CORPO FARFALLATO	THROTTLE BODY	CORPS À PAPILLON	DROSSELKÖRPER	CUERPO MARIPOSA		1	
20	R180200127000	INIETTORE	INJECTOR	INJECTEUR	EINSPRITZDÜSE	INYECTOR		3	
21	R300090140000	KIT CAVO REGOLAZIONE	CABLE FOR ADJUSTMENT KIT	KIT CÂBLE POUR LE RÉGLAGE	KABEL FÜR EINSTELLUNGKIT	KIT CABLE PARA AJUSTE		1	
22	R21313931A	PIASTRINO SPECIALE	SPECIAL PLATE	PLAQUETTE SPÉCIALE	SPEZIALPLÄTTCHEN	LÁMINA ESPECIAL		1	

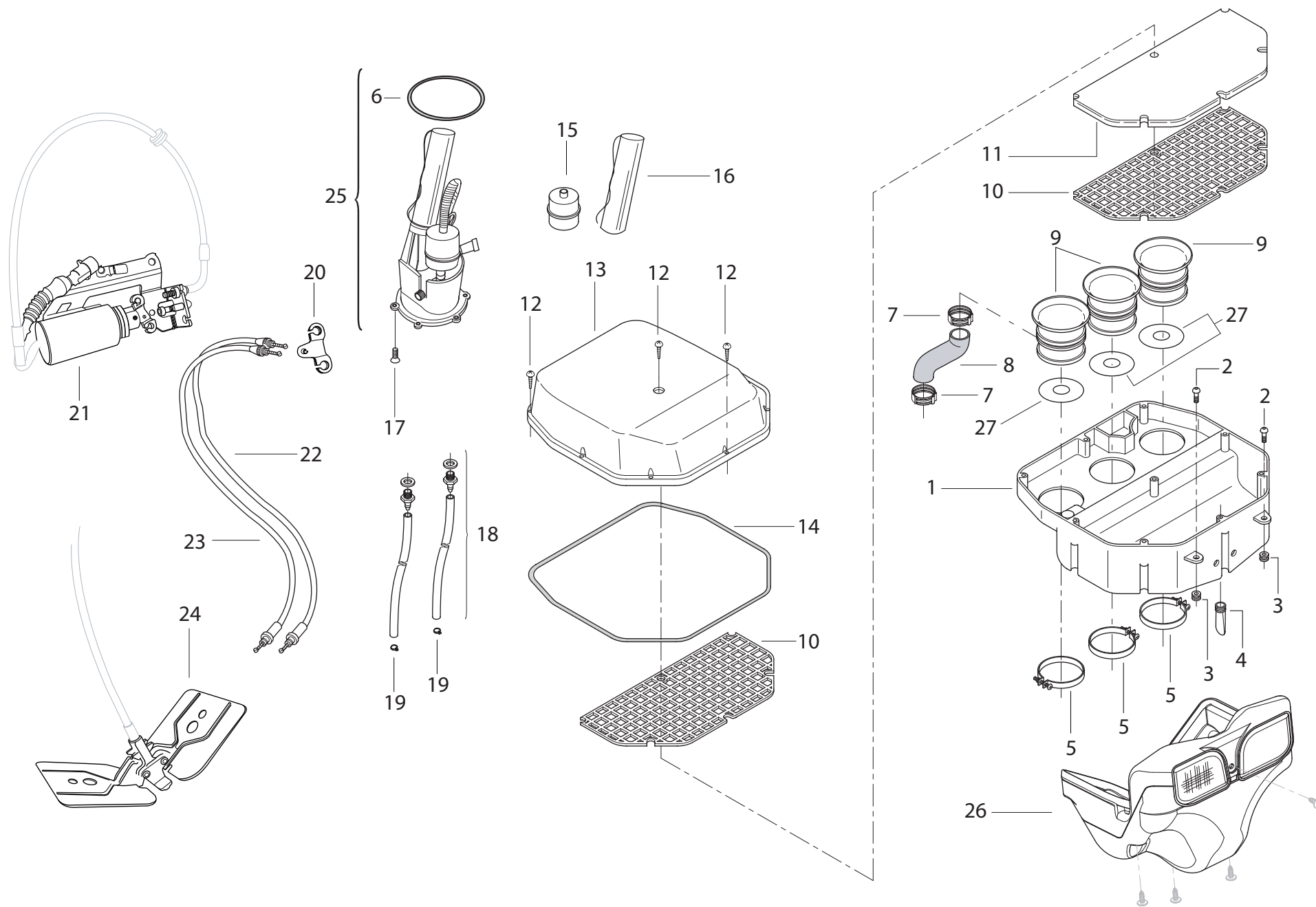

POS. NO. N. INDEX POS.	N. CODICE CODE NO. Nr. CODE ATRIKEL Nr. CODICO Nr.	DESCRIZIONE	DESCRIPTION	DESIGNATION	BEZEICHNUNG	DENOMINACION	NOTE NOTES NOTES MARKE NOTAS	Q.TA' Q.TY Q.TE M.GE C.AD	
1	R300089000000	SCATOLA FILTRO ARIA	AIR FILTER BOX	BOÎTE FILTRE À AIR	LUFILTERKASTEN	CAJA FILTRO AIRE		1	
2	R90750251A0	VITE	SCREW	VIS	SCHRAUBE	TORNILLO		2	
3	R21814461A	PASSACAVO	FAIRLEAD	PASSE-CÂBLE	KABELDURCHFÜHRUNG	PASA-CABLE		2	
4	R180190119000	GOMMINO	RUBBER PAD	JOINT EN CAOUTCHOUC	GUMMISTÜCK	JUNTA DE GOMA		1	
5	R18343751A	FASCETTA CORPI FARFALLATI	THROTTLE BODIES HOSE CLAMP	COLLIERS CARBURATEURS	KLAPPENKÖRPERSCHELLE	ABRAZADERA CUERPOS MARIPOSAS		3	
6	R300090030000	ANELLO DI TENUTA	SEAL RING	BAGUE D'ÉTANCHÉITÉ	DICHTRING	ANILLO DE RETÉN		1	
7	R180184000000	FASCETTA	CLAMP	COLLIER	SHELLE	ABRAZADERA		2	
8	R180190118000	TUBO	TUBE	TUBE	ROHR	TUBO		1	
9	R300036115000	CONDOTTO ASPIRAZIONE	INTAKE DUCT	CONDUIT ASPIRATION	ANSAUGLEITUNG	TUBO ASPIRACIÓN		3	
10	R300089108000	RETE DI RITEGNO	SECURING NET	TREILLIS	HALTENETZ	RED DE RETÉN		2	
11	R21023521A	ELEMENTO FILTRANTE	FILTER ELEMENT	ELÉMENT FILTRANT	FILTERELEMENT	ELEMENTO FILTRANTE		1	
12	R90750662B	VITE	SCREW	VIS	SCHRAUBE	TORNILLO		3	
13	R300089107000	COPERCHIO SCATOLA FILTRO	FILTER CASE COVER	COUVERCLE BOÎTE FILTRE	FILTERGEHÄUSEDECKEL	TAPA CAJA FILTRO		1	
14	R21814541A	GUARNIZIONE	GASKET	GARNITURE	DICHTUNG	JUNTA		1	
15	R180100153000	KIT FILTRO BENZINA	FUEL FILTER KIT	KIT FILTRE À ESSENCE	KIT BENZINFILTER	KIT FILTRO GASOLINA		1	
16	R180190127000	SONDA LIVELLO CARBURANTE	FUEL LEVEL SENSOR	SONDE DE NIVEAU CARBURANT	KRAFTSTOFFPEGELSONDE	SONDA NIVEL COMBUSTIBLE		1	
17	R90750182B	VITE	SCREW	VIS	SCHRAUBE	TORNILLO		1	
18	R6781DDL1B	KIT TUBI	TUBES KIT	KIT TUBES	KIT ROHR	KIT TUBO		1	
19	R95251153B	FASCETTA A MOLLA	SPRING HOSE CLAMP	COLLIER À RESSORT	FEDERSCHELLE	ABRAZADERA A MUELLE		2	
20	R300065012001	BILANCIERE	ROCKER	CULBUTEUR	KIPPEBEL	BILANCÍN		1	
21	R300065010001	ATTUATORE COMPLETO	COMPLETE ACTUATOR	EXECURUER COMPLET	KOMPLETTANTRIEB	ACTUADOR COMPLETO		1	
22	R300065008000	CAVO COMANDO ASPIRAZIONE	INTAKE CONTROL CABLE	CÂBLE COMMANDE ASPIRATION	STEUERKABEL ANSAUGUNG	CABLE MANDO ASPIRACIÓN		1	
23	R310065011000	CAVO COMANDO SCARICO	EXHAUST CONTROL CABLE	CÂBLE COMMANDE D' ÉCHAPPEMENT	STEUERKABEL AUSLAß	CABLE MANDO ESCAPE		1	
24	R300000171000	VALVOLA ASPIRAZIONE	INTAKE VALVE	SOUPAPE D' ASPIRATION	EINLAßVENTIL	VÁLVULA DE ASPIRACIÓN		1	

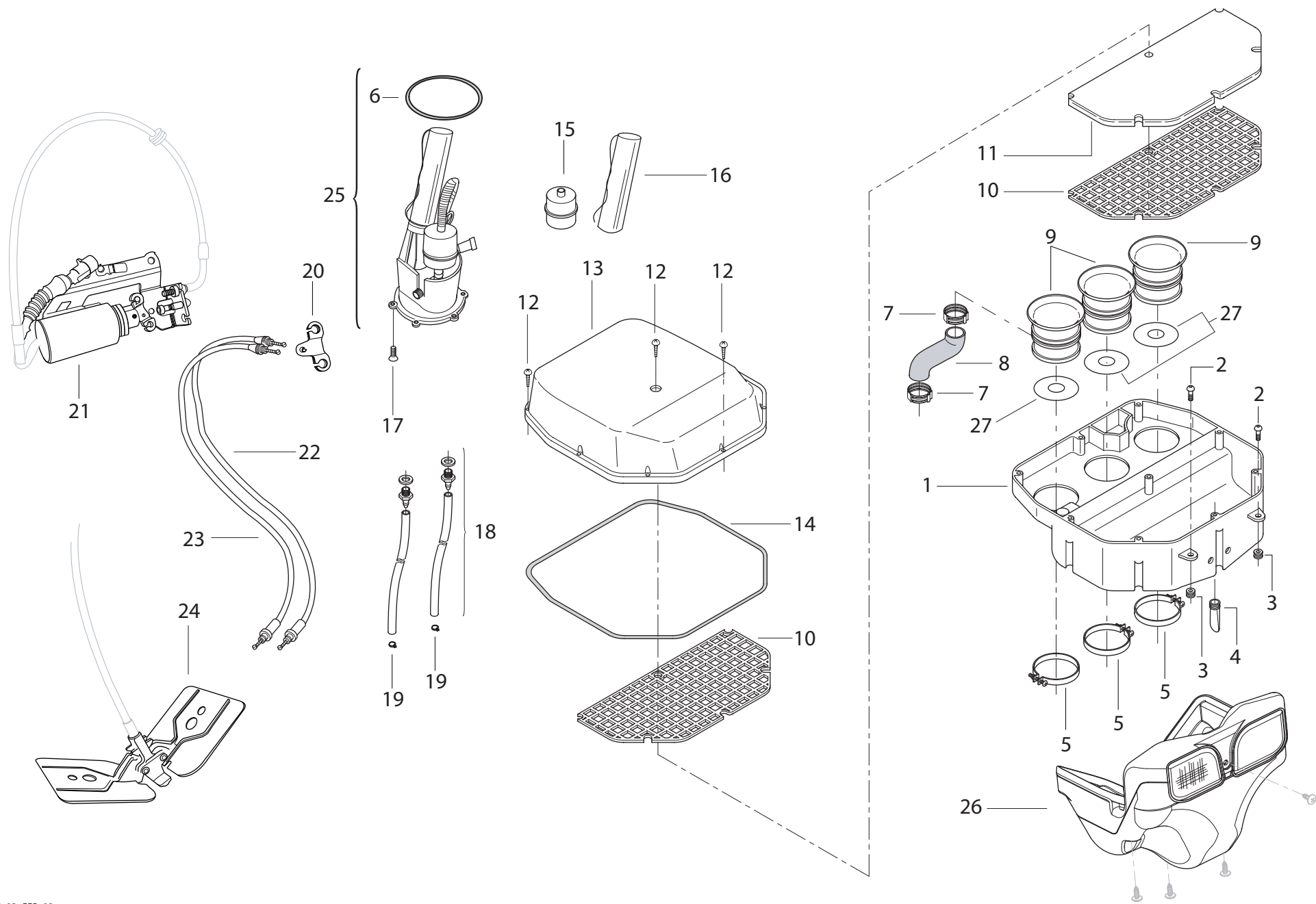

POS. NO. N. INDEX POS.	N. CODICE CODE NO. Nr. CODE ATRIKEL Nr. CODICO Nr.	DESCRIZIONE	DESCRIPTION	DESIGNATION	BEZEICHNUNG	DENOMINACION	NOTE NOTES NOTES MARKE NOTAS	Q.TA' Q.TY Q.TE M.GE C.AD	
25	R67023001A	POMPA BENZINA	FUEL PUMP	POMPE CARBURANT	BENZINPUMPE	BOMBA GASOLINA		1	
26	R310090131000	CONVOGLIATORE	MANIFOLD	CONVOYEUR	FÖRDERER	ENCANALADOR		1	
27	R310090040000	RONDELLA	WASHER	RONDELLE	UNTERLEGSSCHEIBE	ARANDELA		3	

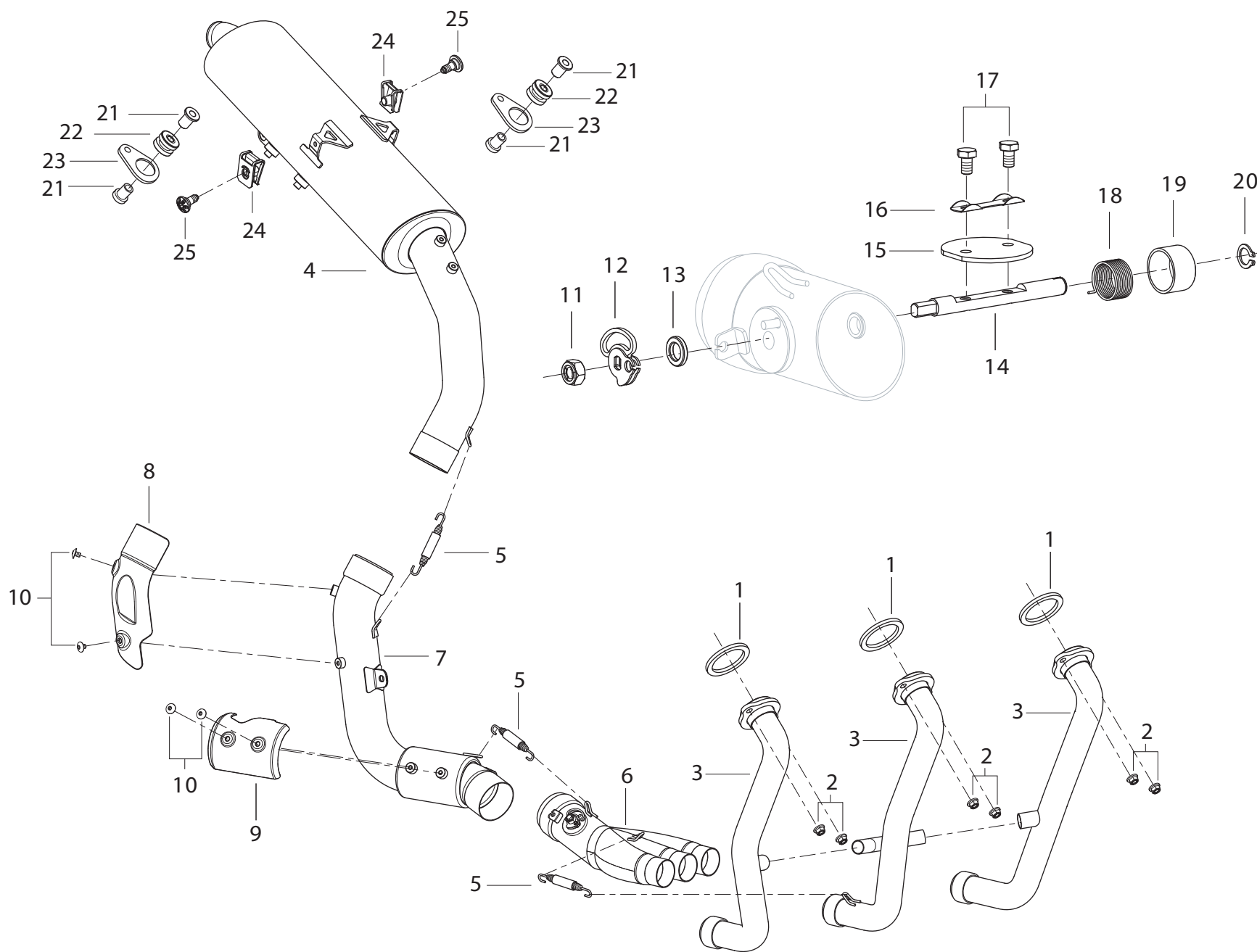

POS. NO. N. INDEX POS.	N. CODICE CODE NO. Nr. CODE ATRIKEL Nr. CODICO Nr.	DESCRIZIONE	DESCRIPTION	DESIGNATION	BEZEICHNUNG	DENOMINACION	NOTE NOTES NOTES MARKE NOTAS	Q.TA' Q.TY Q.TE M.GE C.AD	
1	R14113131A	GUARNIZIONE SCARICO	EXHAUST GASKET	JOINT DE DÉCHARGE	AUSPUFFDICHTUNG	JUNTA ESCAPE		3	
2	R91350082B	DADO	NUT	ECROU	MUTTER	TUERCA		6	
3	R310086013000	COLLETTORE DI SCARICO	EXHAUST MANIFOLD	COLLECTEUR D'ÉCHAPPEMENT	AUSPUFFKRÜMMER	COLECTOR DE ESCAPE		3	
4	R310086102000	SILENZIATORE	SILENCER	SILENCIEUX	SCHALLDÄMPFER	SILENCIADOR		1	
5	R180286011001	MOLLA	SPRING	RESSORT	FEDER	MUELLE		3	
6	R310086007000	COLLETTORE DI SCARICO (TRE IN UNO)	EXHAUST MANIFOLD (THREE IN ONE)	COLLECTEUR D'ÉCHAPPEMENT (TROIS DANS UN)	AUSPUFFKRÜMMER (DREI IN EINS)	COLECTOR DE ESCAPE (TRES EN UNO)		1	
7	R310086135000	RACCORDO COLLETTORE DI SCARICO	CONNECTION COLLECTOR	COLLECTEUR DE RACCORDEMENT	ANSCHLUSS-AUSPUFFKRÜMMER	COLECTOR DE ESCAPE DE LA CONEXIÓN		1	
8	R310057185000	PROTEZIONE TERMICA	THERMAL PROTECTION	PROTECTION THERMIQUE	WÄRMESCHUTZ	PROTECCIÓN TÉRMICA		1	
9	R310057184000	PROTEZIONE TERMICA (CATALIZZATORE)	THERMAL PROTECTION (CATALYST)	PROTECTION THERMIQUE (CATALYSEUR)	WÄRMESCHUTZ (KATALYSATOR)	PROTECCIÓN TÉRMICA (CATALIZADOR)		1	
10	R90752292B	VITE	SCREW	VIS	SCHRAUBE	TORNILLO		4	
11	R91750058E	DADO	NUT	ECROU	MUTTER	TUERCA		1	
12	R300086128000	FLANGIA VALVOLA DI SCARICO	EXHAUST VALVE FLANGE	BRIDE DE SOUPEPE D'ÉCHAPPEMENT	AUSLABVENTIL-FLANSCH	BRIDA VÁLVULA DE DESCARGA		1	
13	R90753002B	RONDELLA	WASHER	RONDELLE	UNTERLEGSCHIEBE	ARANDELA		1	
14	R300086125000	ALBERINO VALVOLA DI SCARICO	EXHAUST MAIN SHAFT	PIVOT DE SOUPEPE D'ÉCHAPPEMENT	ZAPFEN-AUSLABVENTIL	ÁRBOL LA VÁLVULA DE DESCARGA		1	
15	R300086123000	VALVOLA DI SCARICO	EXHAUST VALVE	SOUPEPE D'ÉCHAPPEMENT	AUSLABVENTIL	VÁLVULA DE DESCARGA		1	
16	R300086137000	PIASTRINA	PLATE	PLAQUETTE	PLÄTTCHEN	PLACA		1	
17	R90150628E	VITE	SCREW	VIS	SCHRAUBE	TORNILLO		2	
18	R300086127000	MOLLA	SPRING	RESSORT	FEDER	MUELLE		1	
19	R300086126000	TAPPO VALVOLA DI SCARICO	EXHAUST VALVE CAP	BOUCHON SOUPEPE D'ÉCHAPPEMENT	VERSCHLUß-AUSLABVENTIL	TAPÓN VÁLVULA DE DESCARGA		1	
20	R92450108E	ANELLO ELASTICO	SNAP RING	BAGUE ÉLASTIQUE	SPRENGRING	SEAGER		1	
21	R300079186000	BOCCOLA	BUSH	DOUILLE	BUCHSE	CASQUILLO		4	
22	R180479181000	GOMMINO	RUBBER PAD	JOINT EN CAOUTCHOUC	GUMMISTÜCK	JUNTA DE GOMA		2	
23	R300086134000	BIELLETTA SILENZIATORE	SILENCER CONNECTING ROD	BIELLETTA SILENCIEUX	PLEUELSTANGE AUSPUFFTOPF	BIELA SILENCIADOR		2	
24	R95050012A	CLIP FISSAGGIO RAPIDO	QUIK FASTENING	FIXATION RAPIDE	SCHNELLEBEFESTIGUNG	FIJACIÓN RÁPIDA		2	

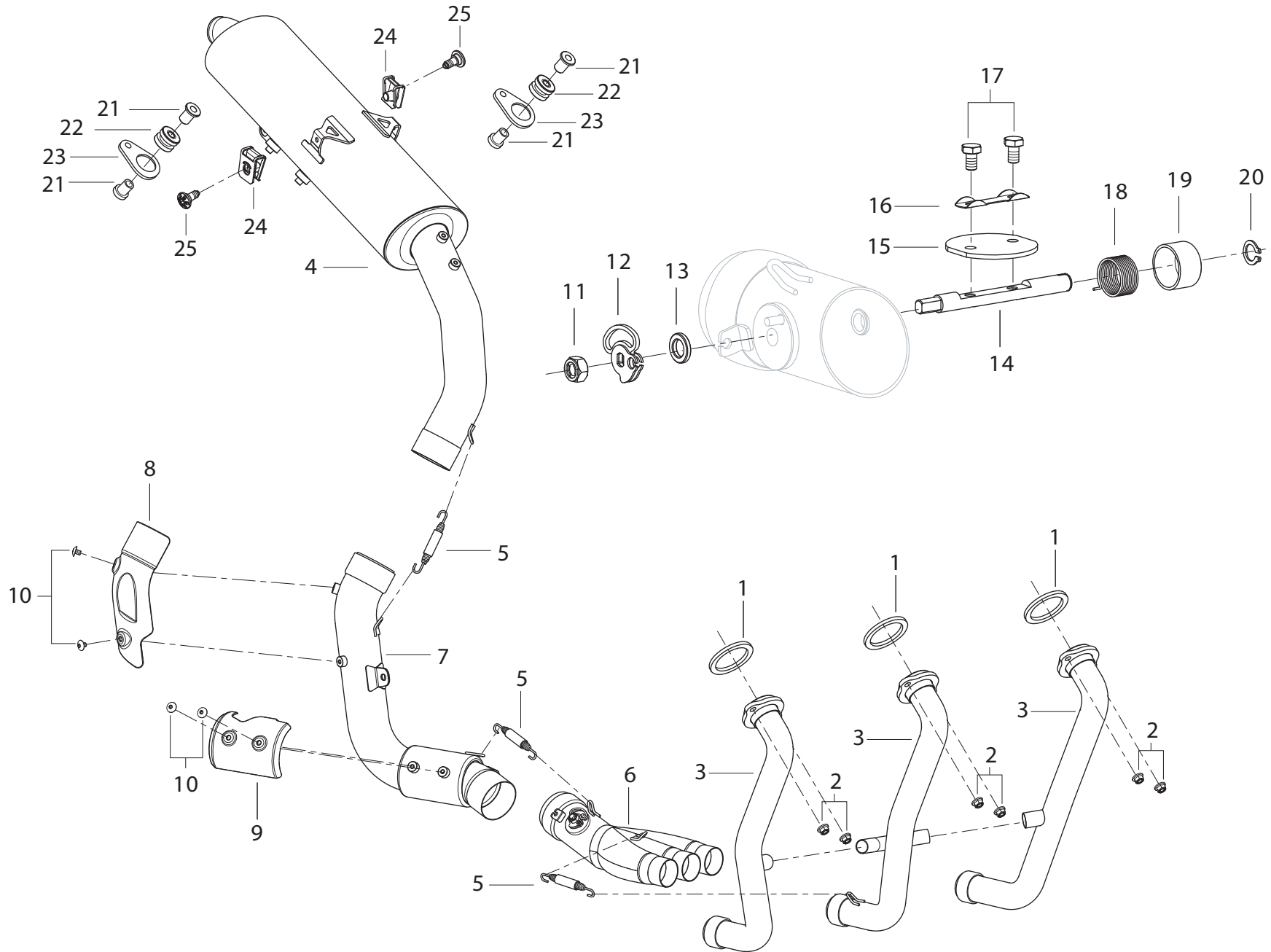

POS. NO. N. INDEX POS.	N. CODICE CODE NO. Nr. CODE ATRIKEL Nr. CODICO Nr.	DESCRIZIONE	DESCRIPTION	DESIGNATION	BEZEICHNUNG	DENOMINACION	NOTE NOTES MARKE NOTAS	Q.TA' Q.TY Q.TE M.GE C.AD	
25	R90750522B	VITE	SCREW	VIS	SCHRAUBE	TORNILLO		2	

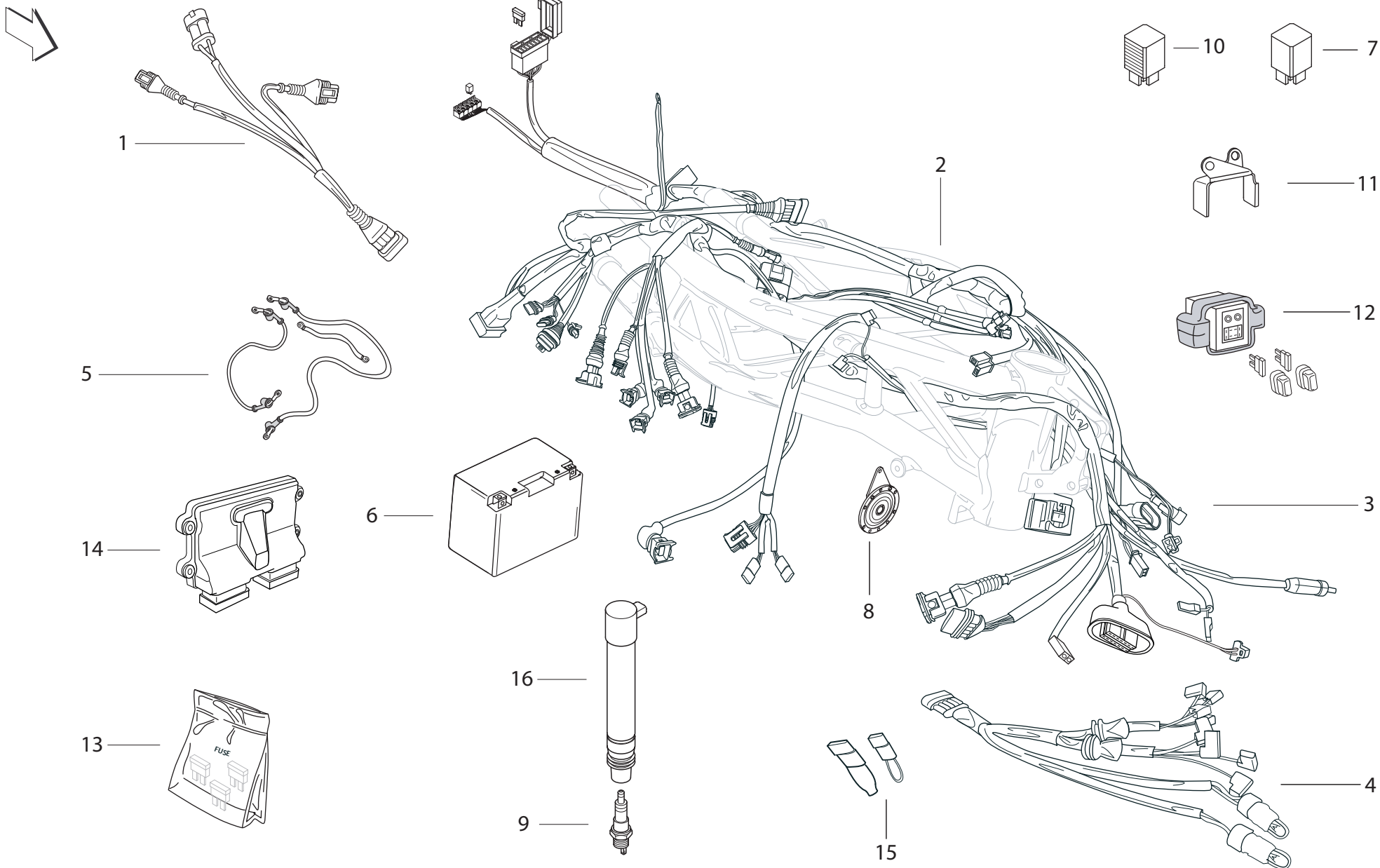



POS. NO. N. INDEX POS.	N. CODICE CODE NO. Nr. CODE ATRIKEL Nr. CODICO Nr.	DESCRIZIONE	DESCRIPTION	DESIGNATION	BEZEICHNUNG	DENOMINACION	NOTE NOTES NOTES MARKE NOTAS	Q.TA' Q.TY Q.TE M.GE C.AD	
1	R310077135000	CABLAGGIO POSTERIORE	REAR WIRING	CÂBLAGE ARRIÈRE	HINTERER VERKABELUNG	CABLEADO TRASERO		1	
2	R310077107000	CABLAGGIO CENTRALE	MAIN WIRING	CÂBLAGE CENTRAL	KABELBAUM	CABLEADO CENTRAL		1	
3	R310077119001	CABLAGGIO INIEZIONE	INJECTION WIRING	INJECTEUR CÂBLAGE	VERKABELUNG EINSPRITZDÜSE	CABLEADO INYECTOR		1	
4	R300077101001	CABLAGGIO ANTERIORE	FRONT WIRING	CÂBLAGE AVANT	VORDERES VERKABELUNG	CABLEADO DELANTERO		1	
5	R300077104001	CABLAGGIO BATTERIA	BATTERY WIRING	CÂBLAGE BATTERIE	VERKABELUNG BATTERIE	CABLEADO BATERÍA		1	
6	R300077100000	BATTERIA	BATTERY	BATTERIE	BATTERIE	BATERÍA		1	
7	R51890211A0	INTERMITTENZA	INTERMITTENTLY	INTERMITTENCE	INTERMITTENZ	IINTERMITENTE		1	
8	R180277105000	AVVISATORE ACUSTICO	HORN	KLAXON	HUPE	CLAXON		1	
9	R290033100000	CANDELA	SPARK PLUG	BOUGIE	ZÜNDKERZE	BUJIA			
10	R180177125000	RELAIS	RELAY	RELAIS	RELAIS	RELÉ		1	
11	R180157134000	PIASTRINO	PLATE	PLAQUETTE	PLÄTTCHEN	LÁMINA		1	
12	R180177122000	RELAIS	RELAY	RELAIS	RELAIS	RELÉ		1	
13	R180100136000	KIT FUSIBILI	FUSE KIT	KIT FUSIBLE	KIT SICHERUNG	KIT FUSIBLE		1	
14	R300077139000	CENTRALINA INIEZIONE	INJECTION CONTROL UNIT	CENTRALE INJECTION	STEUERGEHÄUSE DER EINSPRITZUNG	CENTRALITA INYECCIÓN		1	
15	R300077149000	DIODO	DIODE	DIODE	DIODE	DIODO		1	
16	R51243021A	BOBINA	COIL	BOBINE	ZÜNDSPULE	BOBINA		1	

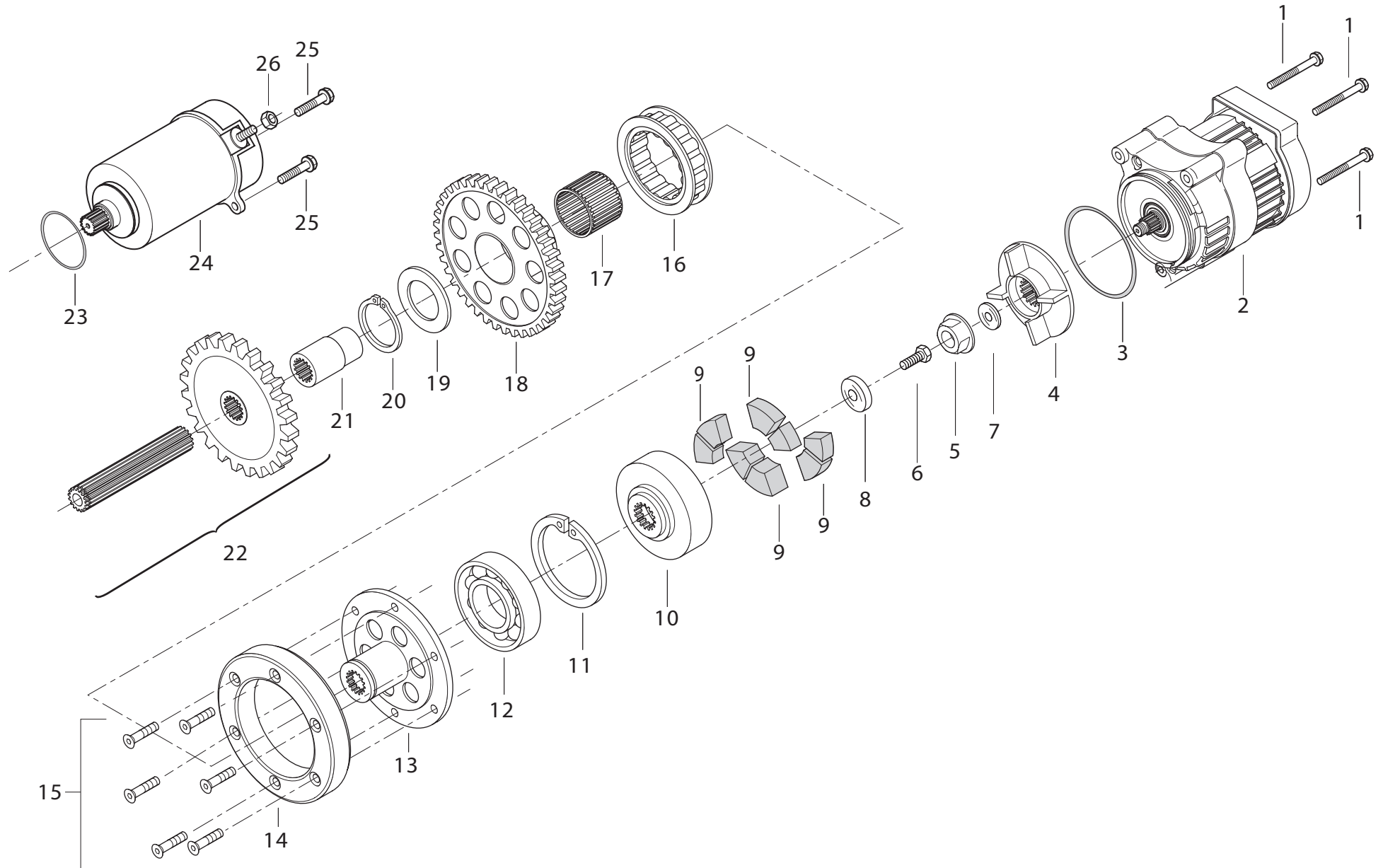

POS. NO. N. INDEX POS.	N. CODICE CODE NO. Nr. CODE ATRIKEL Nr. CODICO Nr.	DESCRIZIONE	DESCRIPTION	DESIGNATION	BEZEICHNUNG	DENOMINACION	NOTE NOTES NOTES MARKE NOTAS	Q.TA' Q.TY Q.TE M.GE C.AD	
1	R90751342B	VITE	SCREW	VIS	SCHRAUBE	TORNILLO		3	
2	R18243011A	ALTERNATORE	GENERATOR	ALTERNATEUR	DREHSTOMGENERATOR	ALTERNADOR		1	
3	R18243091A	GUARNIZIONE OR	O-RING	JOINT D'ÉTANCHÉITÉ	DICHTUNG OR	JUNTA OR		1	
4	R19113071A	GIUNTO MASCHIO	MALE COUPLING	JOINT MÂLE	VERBINDUNGSKUPPLUNG MÄNNLICH	JUNTA MACHO		1	
5	R19143251A	DADO	NUT	ECROU	MUTTER	TUERCA		1	
6	R90752751C	VITE	SCREW	VIS	SCHRAUBE	TORNILLO		1	
7	R310032008000	RONDELLA	WASHER	RONDELLE	UNTERLEGSCHIEBE	ARANDELA		1	
8	R310032007000	RONDELLA SPECIALE	SPECIAL WASHER	RONDELLE SPÉCIALE	SPEZIALUNTERLEGSCHIEBE	ARANDELA ESPECIAL		1	
9	R19113191A	GOMMA PARASTRAPPI	SPRING DRIVE RUBBER	CAOUTCHOUC FLECTEUR	STOESSSCHUTZGUMMI	GOMA JUNTA AMORTIGÜADORA		4	
10	R180232109000	GIUNTO FEMMINA	FEMALE COUPLING	FEMELLE JOINT	VERBINDUNGSKUPPLUNG-FRAU	JUNTA-HEMBRA		1	
11	R92550470D	ANELLO ELASTICO	SNAP RING	BAGUE ÉLASTIQUE	SPRENGRING	SEAGER		1	
12	R11043441A	CUSCINETTO	BEARING	ROULEMENT	LAGER	COJINETE		1	
13	R19113291A	MOZZO RUOTA LIBERA	SPRAG CLUTCH HUB	MOYEU POUR ROUE LIBRE	FREILAUFNABE	CUBO RUEDA LIBRE		1	
14	R19113281A	FLANGIA	FLANGE	BRIDE	FLANSCH	BRIDA		1	
15	R90650520C	VITE	SCREW	VIS	SCHRAUBE	TORNILLO		6	
16	R19143141A	RUOTA LIBERA	STARTER CLUTCH	ROUE LIBRE	FREILAUF	RUEDA LIBRE		1	
17	R19143211A	GABBIA A RULLINI	NEEDLE BEARING	BOÎTE À AIGUILLES	NADELKÄFIG	JAULA DE RODILLOS		1	
18	R19113111A	INGRANAGGIO RUOTA LIBERA Z60	SPRAG CLUTCH GEAR	ENGRENAGE ROUE LIBRE	ZAHNRAD FÜR FREILAUF	ENGRANAJE CUBO RUEDA LIBRE		1	
19	R19113131A	DISTANZIALE	SPACER	ENTRETOISE	DISTANZSTÜCK	DISTANCIAL		1	
20	R92450280D	ANELLO ELASTICO	SNAP RING	BAGUE ÉLASTIQUE	SPRENGRING	SEAGER		1	
21	R19113061A	DISTANZIALE	SPACER	ENTRETOISE	DISTANZSTÜCK	DISTANCIAL		1	
22	R300000081000	KIT INGRANAGGI	GEAR KIT	KIT ENGRENAGE	KIT ZAHNRAD	KIT ENGRANAJE		1	
23	R180134001000	GUARNIZIONE OR	O-RING	JOINT D'ÉTANCHÉITÉ	DICHTUNG OR	JUNTA OR		1	
24	R19243001A	MOTORINO AVVIAMENTO COMPLETO	COMPLETE STARTER MOTOR	DÉMARREUR COMPLET	ELEKTRISCHER ANLAßMOTOR KOMPLETT	MOTOR DE ARRANQUE COMPLETO		1	

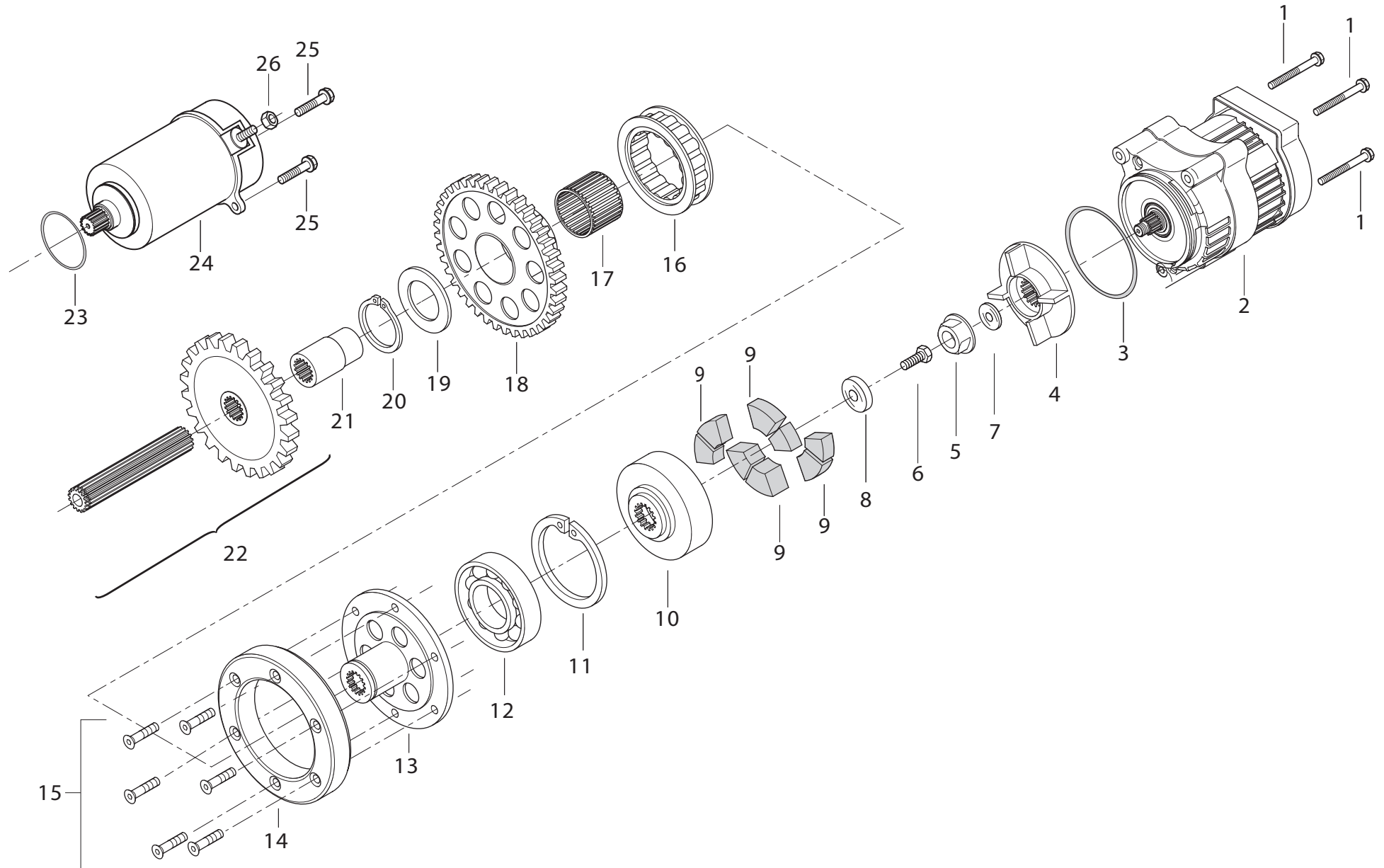

POS. NO. N. INDEX POS.	N. CODICE CODE NO. Nr. CODE ATRIKEL Nr. CODICO Nr.	DESCRIZIONE	DESCRIPTION	DESIGNATION	BEZEICHNUNG	DENOMINACION	NOTE NOTES NOTES MARKE NOTAS	Q.TA' Q.TY Q.TE M.GE C.AD	
25	R90750692B	VITE	SCREW	VIS	SCHRAUBE	TORNILLO		2	
26	R91350072B	DADO	NUT	ECROU	MUTTER	TUERCA		1	

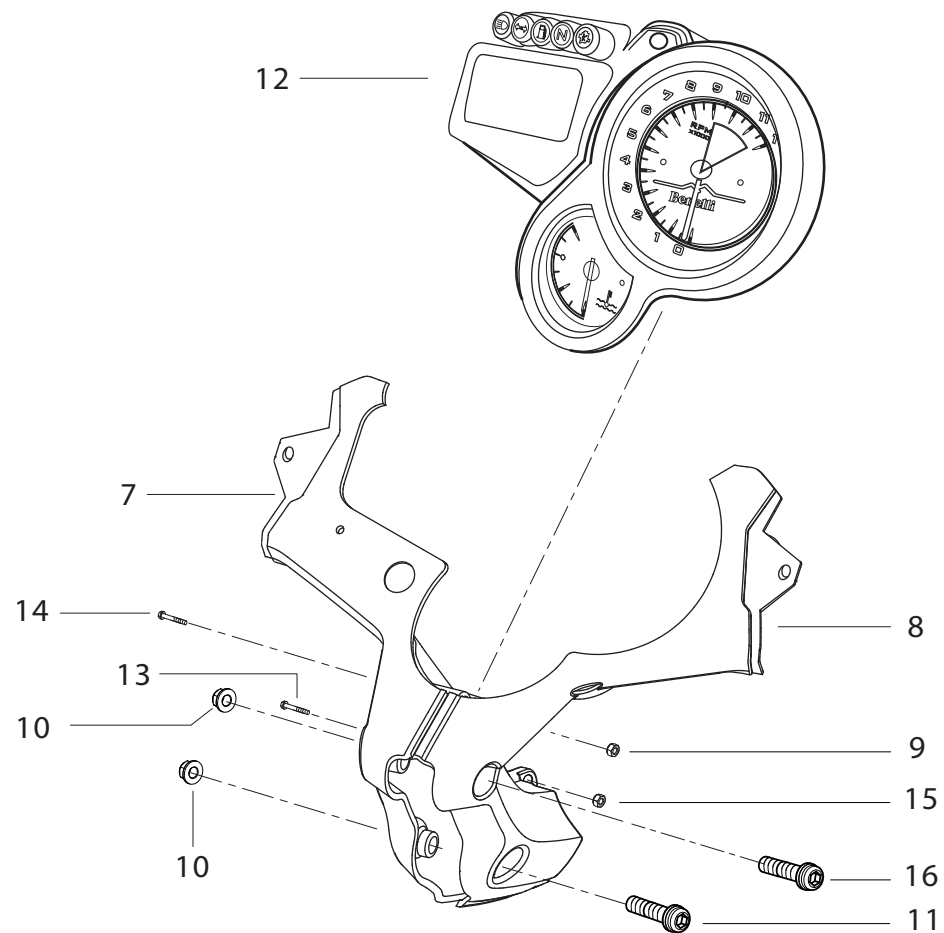
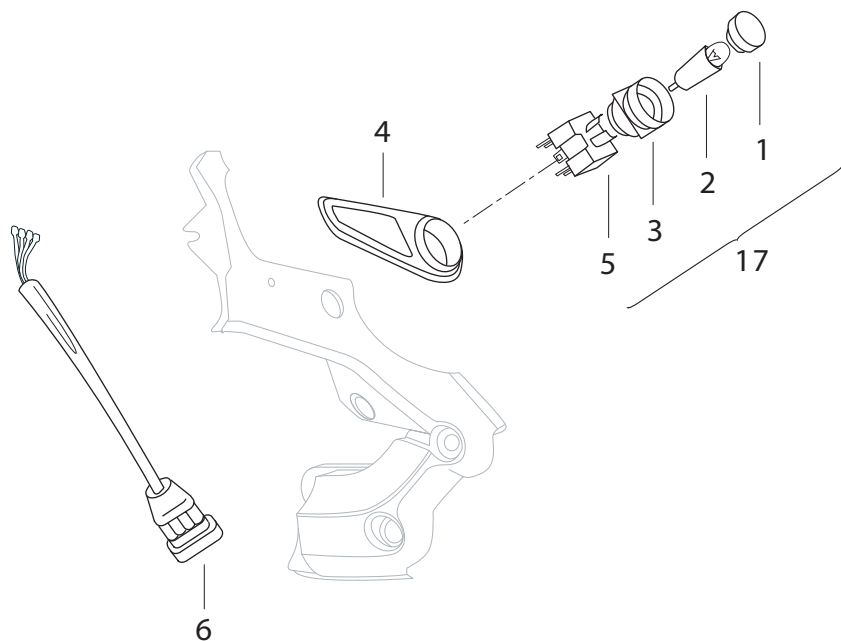



POS. NO. N. INDEX POS.	N. CODICE CODE NO. Nr. CODE ATRIKEL Nr. CODICO Nr.	DESCRIZIONE	DESCRIPTION	DESIGNATION	BEZEICHNUNG	DENOMINACION	NOTE NOTES NOTES MARKE NOTAS	Q.TA' Q.TY Q.TE M.GE C.AD	
1	R300078125000	COPRITASTO	COVER BUTTON	BOUTON DE COUVERTURE	ABDECKUNG TASTE	BOTÓN DE LA CUBIERTA		1	
2	R300078126000	LAMPADA	BULB	LAMPE	BIRNE	LÁMPARA		1	
3	R300078127000	COMMUTATORE	COMMUTATOR	COLLECTEUR	KOMMUTATOR	CONMUTADOR		1	
4	R300074219000	BASE COMMUTATORE	BASE COMMUTATOR	BASE DE COLLECTEUR	KOMMUTATOR-UNTERSEITE	BASE DEL CONMUTADOR		1	
5	R300078128000	CONTATTO COMMUTATORE	COMMUTATOR CONTACT	CONTACT DE COLLECTEUR	KOMMUTATOR-KONTAKT	CONTACTO DEL CONMUTADOR		1	
6	R300077147001	CABLAGGIO	WIRING	CÂBLAGE	VERKABELUNG	CABLEADO		1	
7	R31005001900X	ATTACCO FANALE ANTERIORE SX	FRONT HEAD-LIGHT CONNECTION (L.H.)	FIXATION PHARE AVANT (GAUCHE)	VORDERSCHWEINWERFER (LINKER)	TOMA DE SUJECIÓN DELANTERA (IZQ.)		1	
8	R31005002000X	ATTACCO FANALE ANTERIORE DX	FRONT HEAD-LIGHT CONNECTION (R.H.)	FIXATION PHARE AVANT (DROITE)	VORDERSCHWEINWERFER (RECHTER)	TOMA DE SUJECIÓN DELANTERA (DER.)		1	
9	R91750032B	DADO	NUT	ECROU	MUTTER	TUERCA		1	
10	R91750052B	DADO	NUT	ECROU	MUTTER	TUERCA		2	
11	R90751492B	VITE	SCREW	VIS	SCHRAUBE	TORNILLO		1	
12	R310080000000	STRUMENTO COMPLETO	COMPLETE INSTRUMENT PANEL	TABLEAU DE BORD COMPLET	KOMPLETTES INSTRUMENTENBRETT	TABLERO DE INSTRUMENTOS COMPLETO		1	
13	R90750532B	VITE	SCREW	VIS	SCHRAUBE	TORNILLO		1	
14	R90750522B	VITE	SCREW	VIS	SCHRAUBE	TORNILLO		1	
15	R91350072B	DADO	NUT	ECROU	MUTTER	TUERCA		1	
16	R90751502B	VITE	SCREW	VIS	SCHRAUBE	TORNILLO		1	
17	R300078129000	ASSIEME COMMUTATORE MAPPA	MAP COMMUTATOR ASSEMBLY	ENSEMBLE COLLECTEUR PLAN	KOMMUTATOR LANDKARTE KOMPLETT	GRUPO CONMUTADOR MAPA		1	

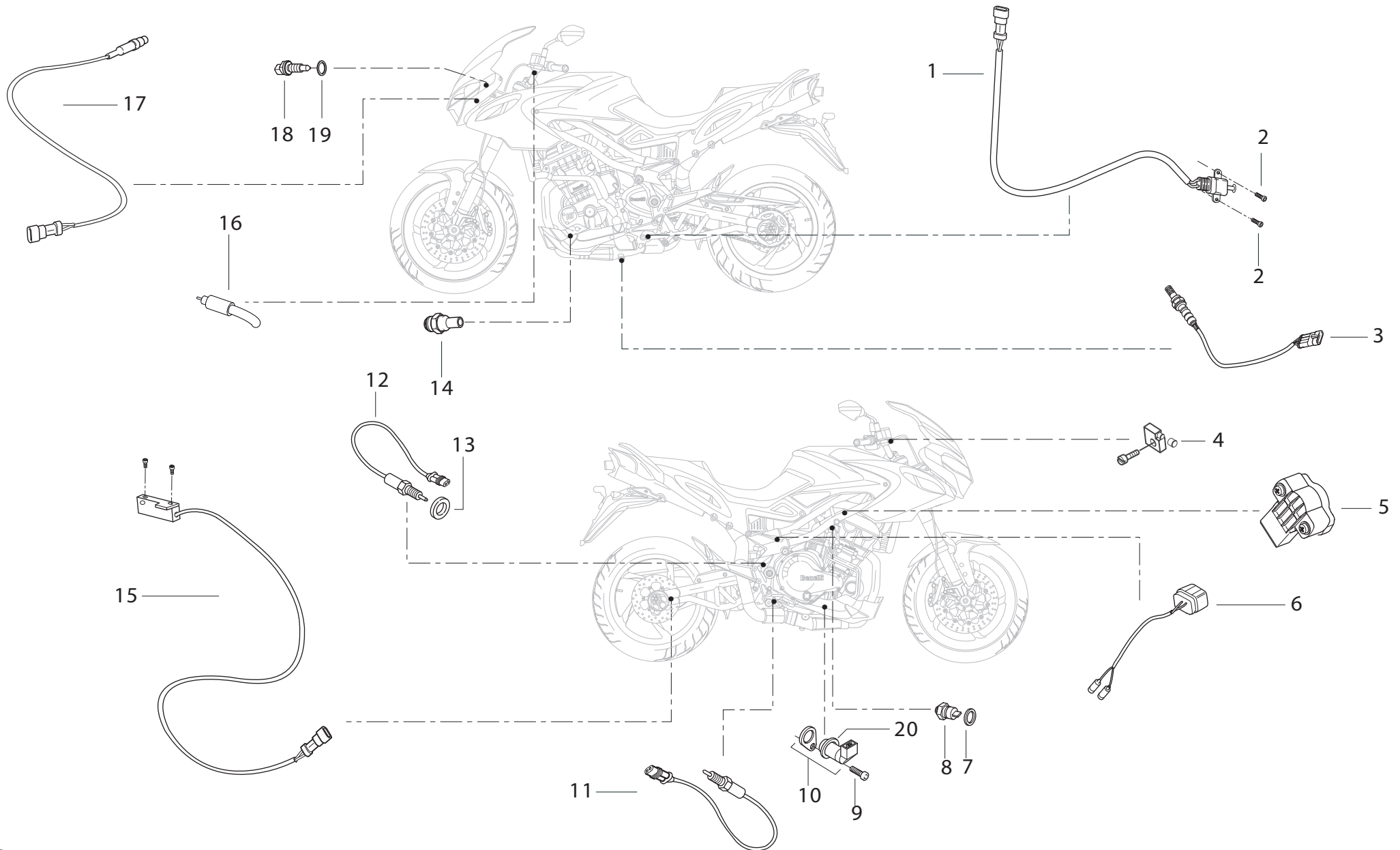

POS. NO. N. INDEX POS.	N. CODICE CODE NO. Nr. CODE ATRIKEL Nr. CODICO Nr.	DESCRIZIONE	DESCRIPTION	DESIGNATION	BEZEICHNUNG	DENOMINACION	NOTE NOTES NOTES MARKE NOTAS	Q.TA' Q.TY Q.TE M.GE C.AD	
1	R51840151A0	SENSORE CAVALLETTO LATERALE	SIDE STAND SENSOR	CAPTEUR BÉQUILLE LATERALE	SENSOR SEITENSTÄNDER	SENSOR CABALLETE LATERAL		1	
2	R90750392B	VITE	SCREW	VIS	SCHRAUBE	TORNILLO		2	
3	R310077152000	SONDA LAMBDA	LAMBDA SENSOR	LAMBDA SENSOR	LAMBDA SENSOR	LAMBDA SENSOR		1	
4	R300063014000	SENSORE FRENO ANTERIORE	FRONT BRAKE SENSOR	CAPTEUR FREIN AVANT	SENSOR VORDBREMSE	SENSOR FRENO DELANTERO		1	
5	R180137000000	POTENZIOMETRO	POTENTIOMETER	POTENTIOMÈTRE	POTENTIOMETER	POTENCIÓMETRO		1	
6	R300077144000	SENSORE DI CADUTA	SENSOR	CAPTEUR	SENSOR	SENSOR		1	
7	R11543441A	RONDELLA DI TENUTA	STOP WASHER	RONDELLE D' ETANCHÉITÉ	DICHTUNGSRING	ARANDELA DE RETÉN		1	
8	R11523371A	VALVOLA SOVRAPPRESSIONE OLIO	OIL OVER PRESURE VALVE	SOUPAPE SURPRESSION HUILE	ÜBERDRUCK ÖLVENTIL	VÁLVULA SUPERPRESIÓN ACEITE		1	
9	R90750482B	VITE	SCREW	VIS	SCHRAUBE	TORNILLO		1	
10	R18243141A	SENSORE DI FASE	PHASE SENSOR	CAPTEUR DE PHASE	PHASENFÜHLER	SENSOR DE FASE		1	
11	R180277113000	HYDROSTOP POSTERIORE	REAR HYDROSTOP	HYDROSTOP ARRIÈRE	HINTERER HYDROSTOPP	HYDROSTOP TRASERO		1	
12	R18243271A	INTERRUTTORE FOLLE	NEUTRAL SWITCH	INTERRUPTEUR DU NEUTRE	LEERLAUFSCHALTER	INTERRUPTOR LIBRE		1	
13	R11043701A	RONDELLA DI TENUTA	STOP WASHER	RONDELLE D' ETANCHÉITÉ	DICHTUNGSRING	ARANDELA DE RETÉN		1	
14	R18243081A	SENSORE PRESSIONE	PRESSURE SENSOR	CAPTEUR PRESSION	DRUCKSENSOR	SENSOR PRESIÓN		1	
15	R300081101000	SENSORE VELOCITA'	SPEED SENSOR	SPEED SENSOR	SPEED SENSOR	SPEED SENSOR		1	
16	R180177123000	SENSORE FRIZIONE	CLUTCH SENSOR	CAPTEUR EMBRAYAGE	SENSOR KUPPLUNG	SENSOR EMBRAGUE		1	
17	R180177132000	SONDA TEMPERATURA	TEMPERATURE SENSOR	SONDE TEMPÉRATURE	TEMPERATURSONDE	SONDA TEMPERATURA		1	
18	R300077145000	SENSORE TEMPERATURA ARIA	AIR TEMPERATURE SENSOR	CAPTEUR TEMPÉRATURE AIR	LUFTEMPERATURSENSOR	SENSOR TEMPERATURA AIRE		1	
19	R91350092B	DADO	NUT	ECROU	MUTTER	TUERCA		1	
20	R300037024000	GUARNIZIONE OR	O-RING	JOINT D' ÉTANCHÉITÉ	DICHTUNG OR	JUNTA OR		1	

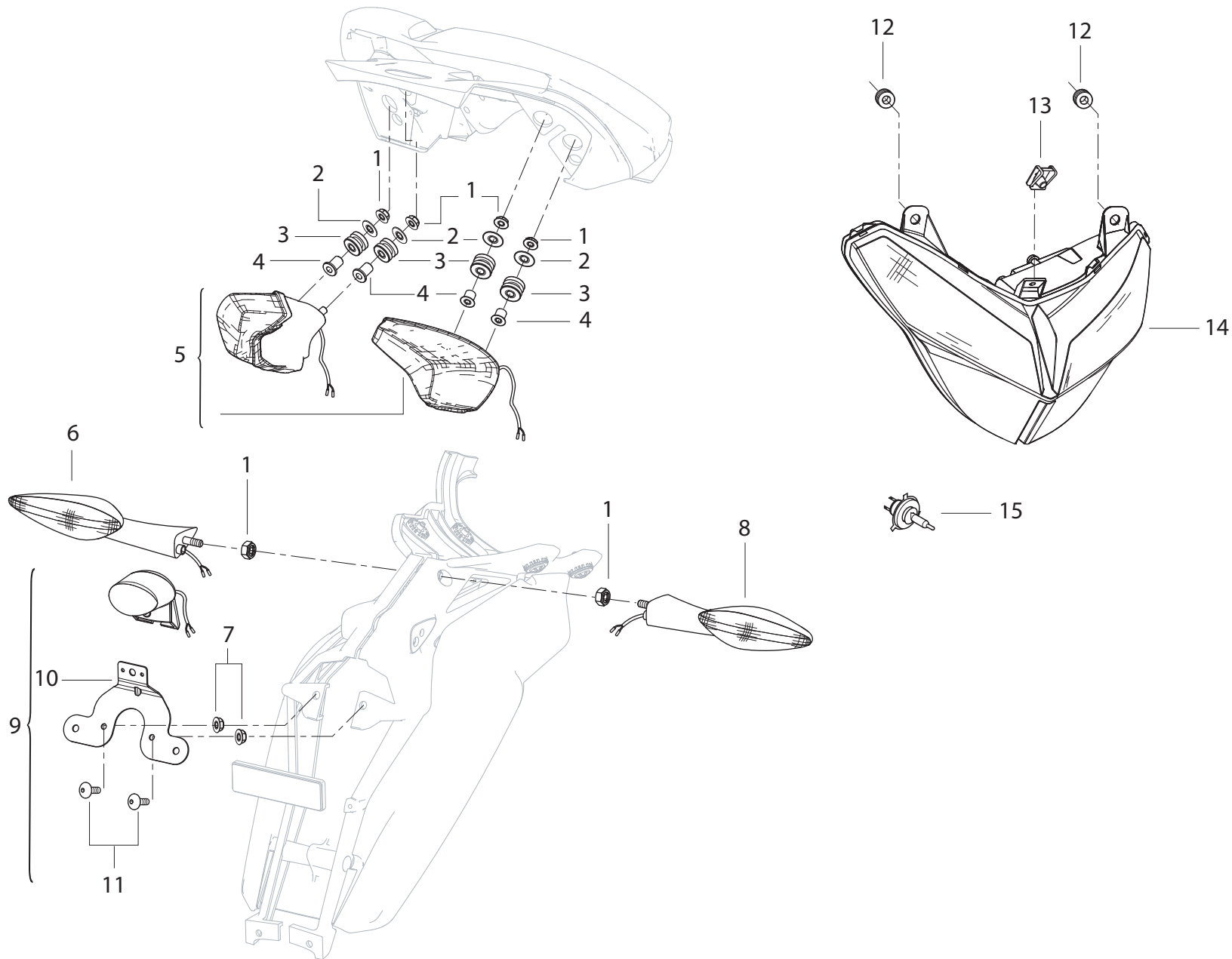

POS. NO. N. INDEX POS.	N. CODICE CODE NO. Nr. CODE ATRIKEL Nr. CODICO Nr.	DESCRIZIONE	DESCRIPTION	DESIGNATION	BEZEICHNUNG	DENOMINACION	NOTE NOTES NOTES MARKE NOTAS	Q.TA' Q.TY Q.TE M.GE C.AD	
1	R91350072B	DADO	NUT	ECROU	MUTTER	TUERCA		6	
2	R92051002B	RONDELLA	WASHER	RONDELLE	UNTERLEGSCHIEBE	ARANDELA		4	
3	R300079190000	ANTIVIBRANTE	VIBRATION DAMPER	ANTIVIBRATION	SCHWINGUNGSDÄMPFER	ANTI-VIBRACIÓN		4	
4	R300079191000	BOCCOLA	BUSH	DOUILLE	BUCHSE	CASQUILLO		4	
5	R300078118000	FARO POSTERIORE COMPLETO	COMPLETE REAR LIGHT	FEU ARRIÈRE COMPLET	RÜCKLICHT KOMPLETT	FARO TRASERO COMPLETO		1	
6	R180278003000	INDICATORE DIREZIONE POST. SX	REAR L.H. TURN INDICATOR	CLIGNOTANT ARRIÈRE GAUCHE	FAHRTRICHTUNGSANZEIGE HINTERERS LINK	INDICADOR DE DIRECCIÓN TRASERO IZQ.		1	
7	R91350062B	DADO	NUT	ECROU	MUTTER	TUERCA		2	
8	R180278004000	INDICATORE DIREZIONE POST.DX	REAR R.H. TURN INDICATOR	CLIGNOTANT ARRIÈRE DROIT	FAHRTRICHTUNGSANZEIGE HINTERERS RECHT	INDICADOR DE DIRECCIÓN TRASERO DER.		1	
9	R300078123001	LUCE TARGA	NUMBER PLATE LIGHT	FEU PLAQUE MINERALOGIQUE	KENNZEICHENBELEUCHTUNG	LUZ MATRÍCULA		1	
10	R300057158000	PIASTRINO	PLATE	PLAQUETTE	PLÄTTCHEN	LÁMINA		1	
11	R90750182B	VITE	SCREW	VIS	SCHRAUBE	TORNILLO		2	
12	R100279118000	GOMMINO ANTIVIBRANTE	VIBRATION DAMPER PAD	JOINT EN CAOUTCHOUC ANTI-VIBRATION	SCHWINGUNGSDÄMPFERGUMMI	JUNTA DE GOMA ANTI-VIBRACIÓN		2	
13	R95050012A	CLIP FISSAGGIO RAPIDO	QUIK FASTENING	FIXATION RAPIDE	SCHNELLEBEFESTIGUNG	FIJACIÓN RÁPIDA		1	
14	R300078000000	FANALE ANTERIORE	FRONT HEAD LIGHT	PHARE AVANT	VORDESCHINWERFER	FARO DELANTERO		1	
15	R180178116000	LAMPADA	BULB	LAMPE	BIRNE	LÁMPARA		1	

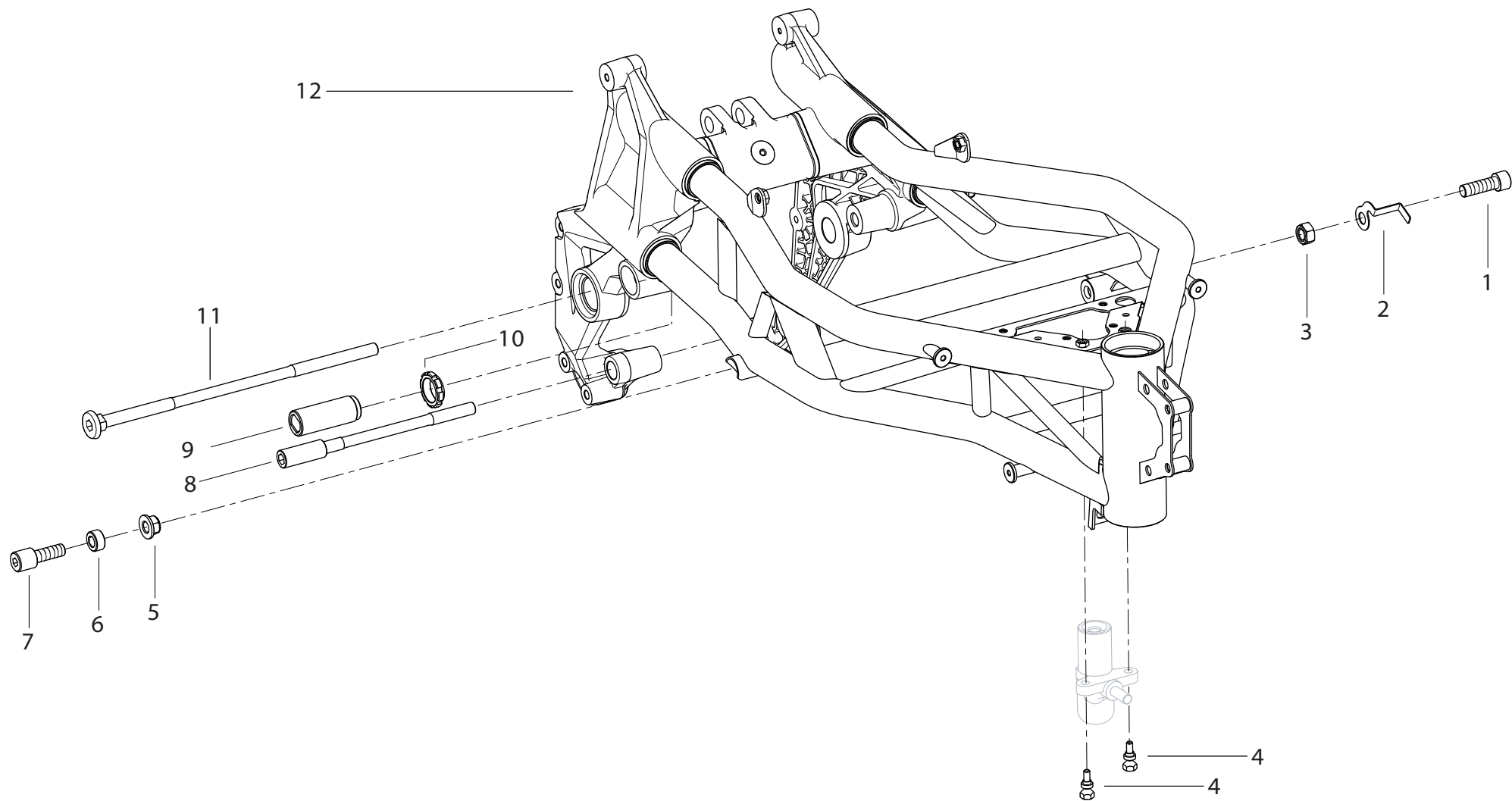

POS. NO. N. INDEX POS.	N. CODICE CODE NO. Nr. CODE ATRIKEL Nr. CODICO Nr.	DESCRIZIONE	DESCRIPTION	DESIGNATION	BEZEICHNUNG	DENOMINACION	NOTE NOTES NOTES MARKE NOTAS	Q.TA' Q.TY Q.TE M.GE C.AD	
1	R21214671A	VITE	SCREW	VIS	SCHRAUBE	TORNILLO		1	
2	R180157137000	PIASTRINO	PLATE	PLAQUETTE	PLÄTTCHEN	PLACA		1	
3	R90752212B	DADO	NUT	ECROU	MUTTER	TUERCA		1	
4	R180166008000	VITE	SCREW	VIS	SCHRAUBE	TORNILLO		2	
5	R91350102B	DADO	NUT	ECROU	MUTTER	TUERCA		1	
6	R310052002000	GRANO	DOWEL	VIS SANS TÊTE	STIFT	CLAVIJA		1	
7	R310052000000	VITE SPECIALE	SPECIAL SCREW	VIS SPÉCIALE	SPEZIALSCHRAUBE	TORNILLO ESPECIAL		1	
8	R310052004000	VITE SPECIALE	SPECIAL SCREW	VIS SPÉCIALE	SPEZIALSCHRAUBE	TORNILLO ESPECIAL		1	
9	R21214611A	REGISTRO	ADJUSTER	RÉGLAGE	REGISTER	REGISTRO		1	
10	R21215411A	GHIERA	RING NUT	EMBOUT	NUTMUTTER	TUERCA		1	
11	R21214581A	VITE SPECIALE	SPECIAL SCREW	VIS SPÉCIALE	SPEZIALSCHRAUBE	TORNILLO ESPECIAL		1	
12	R3100500000CO	TELAIO (ROSSO BITTER)	FRAME (RED BITTER)	CADRE (ROUGE BITTER)	RAHMEN (ROT BITTER)	CHASIS (ROJO BITTER)		1	
12	R3100502180CM	TELAIO (NERO)	FRAME (BLACK)	CADRE (NOIR)	RAHMEN (SCHWARZ)	CHASIS (NEGRO)		1	

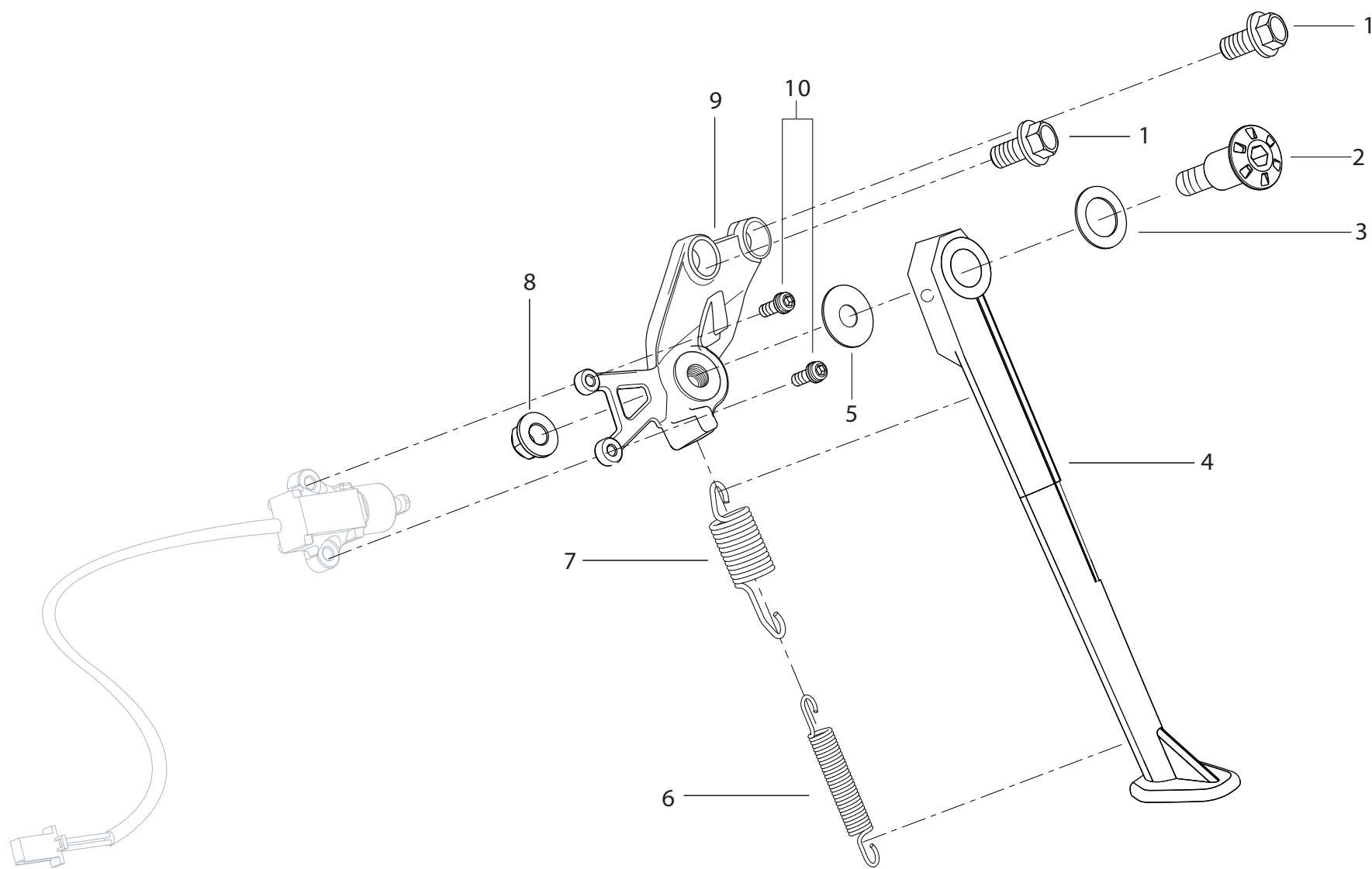

POS. NO. N. INDEX POS.	N. CODICE CODE NO. Nr. CODE ATRIKEL Nr. CODICO Nr.	DESCRIZIONE	DESCRIPTION	DESIGNATION	BEZEICHNUNG	DENOMINACION	NOTE NOTES NOTES MARKE NOTAS	Q.TA' Q.TY Q.TE M.GE C.AD	
1	R310055107000	VITE	SCREW	VIS	SCHRAUBE	TORNILLO		2	
2	R21215361A	VITE SPECIALE	SPECIAL SCREW	VIS SPÉCIALE	SPEZIALSCHRAUBE	TORNILLO ESPECIAL		1	
3	R21215341A	RONDELLA	WASHER	RONDELLE	UNTERLEGSCHIEBE	ARANDELA		1	
4	R310055002000	CAVALLETTO LATERALE	SIDE STAND	BÉQUILLE LATERALE	SEITENSTÄNDER	CABALLETE LATERAL		1	
5	R90752141A	RONDELLA	WASHER	RONDELLE	UNTERLEGSCHIEBE	ARANDELA		1	
6	R300055104000	MOLLA INTERNA	INNER SPRING	RESSORT INTERNE	INNERE FEDER	MUELLE INTERIOR		1	
7	R300055105000	MOLLA ESTERNA	OUTER SPRING	RESSORT EXTERNE	ÄÜßERE FEDER	MUELLE EXTERIOR		1	
8	R91350092B	DADO	NUT	ECROU	MUTTER	TUERCA		1	
9	R310055102000	PIASTRA	PLATE	PLAQUE	PLATTE	SOPORTE		1	
10	R90750392B	VITE	SCREW	VIS	SCHRAUBE	TORNILLO		2	

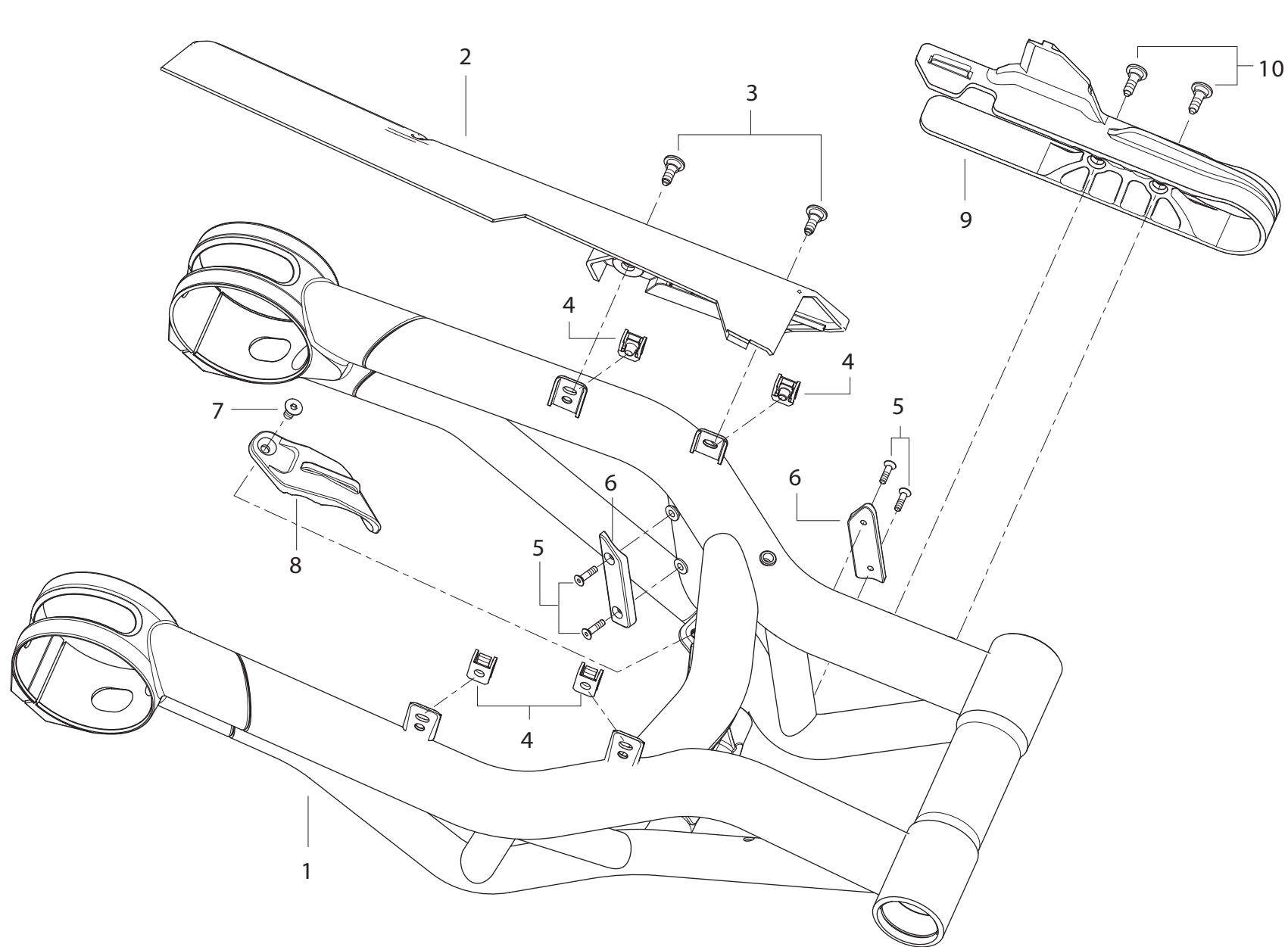

POS. NO. N. INDEX POS.	N. CODICE CODE NO. Nr. CODE ATRIKEL Nr. CODICO Nr.	DESCRIZIONE	DESCRIPTION	DESIGNATION	BEZEICHNUNG	DENOMINACION	NOTE NOTES NOTES MARKE NOTAS	Q.TA' Q.TY Q.TE M.GE C.AD	
1	R3000700000CM	FORCELLONE (NERO)	SWINGARM (BLACK)	FOURCHE (NOIR)	SCHWINGE (SCHWARZ)	BASCULANTE (NEGRO)		1	
1	R3000700000CO	FORCELLONE (ROSSO BITTER)	SWINGARM (RED BITTER)	FOURCHE (ROUGE BITTER)	SCHWINGE (ROT BITTER)	BASCULANTE (ROJO BITTER)		1	
2	R3000742060CA	COPRI CATENA	CHAIN CARTER	CARTER CHAÎNE	KETTENABDECKUNG	CUBRE-CADENA		1	
3	R90752268E	VITE	SCREW	VIS	SCHRAUBE	TORNILLO		2	
4	R95050012A	CLIP FISSAGGIO RAPIDO	QUIK FASTENING	FIXATION RAPIDE	SCHNELLBEFESTIGUNG	FIJACIÓN RÁPIDA		4	
5	R90650222B	VITE	SCREW	VIS	SCHRAUBE	TORNILLO		4	
6	R300027027000	PATTINO CATENA	CHAIN SLIDING SHOE	PATIN CHAÎNE	KETTENGLEITSCHUN	PATÍN CADENA		2	
7	R90650482B	VITE	SCREW	VIS	SCHRAUBE	TORNILLO		1	
8	R300027028000	PATTINO CATENA INFERIORE	LOWER CHAIN SLIDING SHOE	PATIN CHAÎNE INFÉRIEURE	UNTERER KETTENGLEITSCHUN	PATÍN CADENA INFERIOR		1	
9	R300070160000	PATTINO CATENA SUPERIORE	UPPER CHAIN SLIDING SHOE	PATIN CHAÎNE SUPÉRIEURE	OBERER KETTENGLEITSCHUN	PATÍN CADENA SUPERIOR		1	
10	R90750708E	VITE	SCREW	VIS	SCHRAUBE	TORNILLO		2	



ASSIEME FORCELLONE



SWING ARM ASSEMBLY



ENSEMBLE FOURCHE



GABEL KOMPLETT



GRUPO BASCULANTE

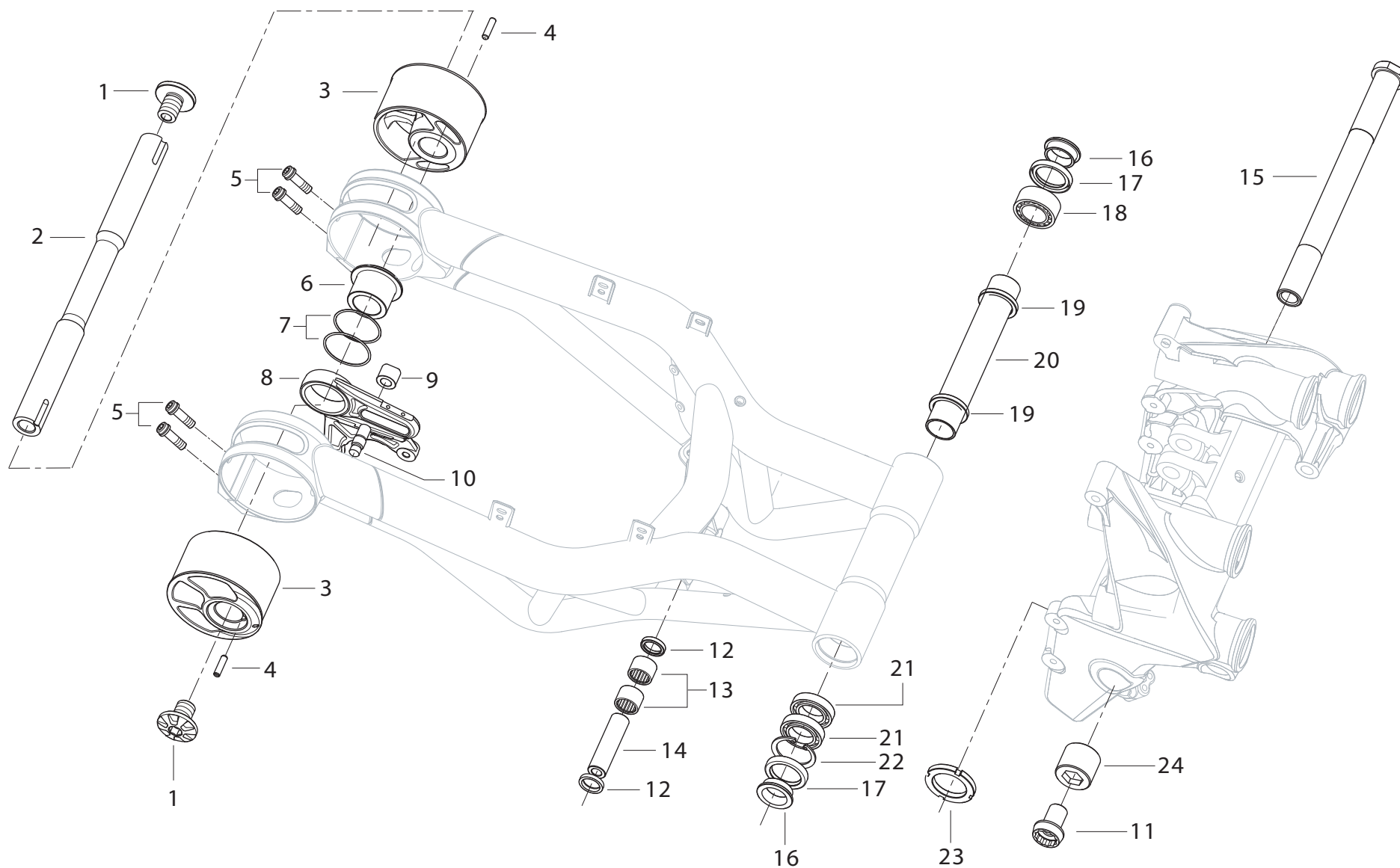



POS. NO. N. INDEX POS.	N. CODICE CODE NO. Nr. CODE ATRIKEL Nr. CODICO Nr.	DESCRIZIONE	DESCRIPTION	DESIGNATION	BEZEICHNUNG	DENOMINACION	NOTE NOTES NOTES MARKE NOTAS	Q.TA' Q.TY Q.TE M.GE C.AD	
1	R300072119000	VITE SPECIALE	SPECIAL SCREW	VIS SPÉCIALE	SPEZIALSCHRAUBE	TORNILLO ESPECIAL		2	
2	R300072108000	PERNO	PIN	PIVOT	ZAPFEN	PERNO		1	
3	R300000096000	KIT ECCENTRICO	ECCENTRIC KIT	KIT EXCENTRIQUE	KIT EXZENTERNABE	KIT EXCÉNTRICO		1	
4	R93850060C	SPINA	PIN	GOUPILLE	STIFT	PASADOR		2	
5	R90751452B	VITE	SCREW	VIS	SCHRAUBE	TORNILLO		4	
6	R300063123000	BOCCOLA	BUSH	DOUILLE	BUCHSE	CASQUILLO		1	
7	R300063126000	GUARNIZIONE OR	O-RING	JOINT D'ÉTANCHÉITÉ	DICHTUNG OR	JUNTA OR		2	
8	R300063116000	PIASTRA PORTAPINZA	CALIPER HOLDER PLATE	PLAQUE PORTE-PINCE	BREMSZANGENPLATTE	LÁMINA PORTA-PINZA		1	
9	R300063125000	BOCCOLA	BUSH	DOUILLE	BUCHSE	CASQUILLO		1	
10	R300070139000	PERNO	PIN	PIVOT	ZAPFEN	PERNO		1	
11	R21214511A	VITE SPECIALE	SPECIAL SCREW	VIS SPÉCIALE	SPEZIALSCHRAUBE	TORNILLO ESPECIAL		1	
12	R21813741A	ANELLO DI TENUTA	SEAL RING	BAGUE D'ÉTANCHÉITÉ	DICHTRING	ANILLO DE RETÉN		2	
13	R21215011A	CUSCINETTO A RULLI	ROLLER BEARING	COUSSINET A ROULEAUX	ROLLENLAGER	COJINETE RODILLOS		2	
14	R21214761A	DISTANZIALE	SPACER	ENTRETOISE	DISTANZSTÜCK	DISTANCIAL		1	
15	R180270001000	PERNO	PIN	PIVOT	ZAPFEN	PERNO		1	
16	R300072122000	BOCCOLA	BUSH	DOUILLE	BUCHSE	CASQUILLO		2	
17	R300002034000	ANELLO DI TENUTA	SEAL RING	BAGUE D'ÉTANCHÉITÉ	DICHTRING	ANILLO DE RETÉN		2	
18	R300002033000	CUSCINETTO A RULLI	ROLLER BEARING	COUSSINET A ROULEAUX	ROLLENLAGER	COJINETE RODILLOS		1	
19	R300070138000	ANELLO DI CENTRAGGIO	CENTERING RING	BAGUE DE CENTRAGE	ZENTRIERRING	ANILLO DE CENTRADO		2	
20	R300070137000	DISTANZIALE INTERNO	INNER SPACER	ENTRETOISE INTERNE	INNERES DISTANZSTÜCK	DISTANCIADOR INTERIOR		1	
21	R300002032000	CUSCINETTO	BEARING	ROULEMENT	LAGER	COJINETE		2	
22	R92550420D	ANELLO SEEGER	CIRCLIP	CIRCLIP	SEEGERRING	ANILLO SEEGER		1	
23	R21214551A	GHIERA	RING NUT	EMBOUT	NUTMUTTER	TUERCA		1	
24	R21214541A	REGISTRO	ADJUSTER	RÉGLAGE	REGISTER	REGISTRO		1	

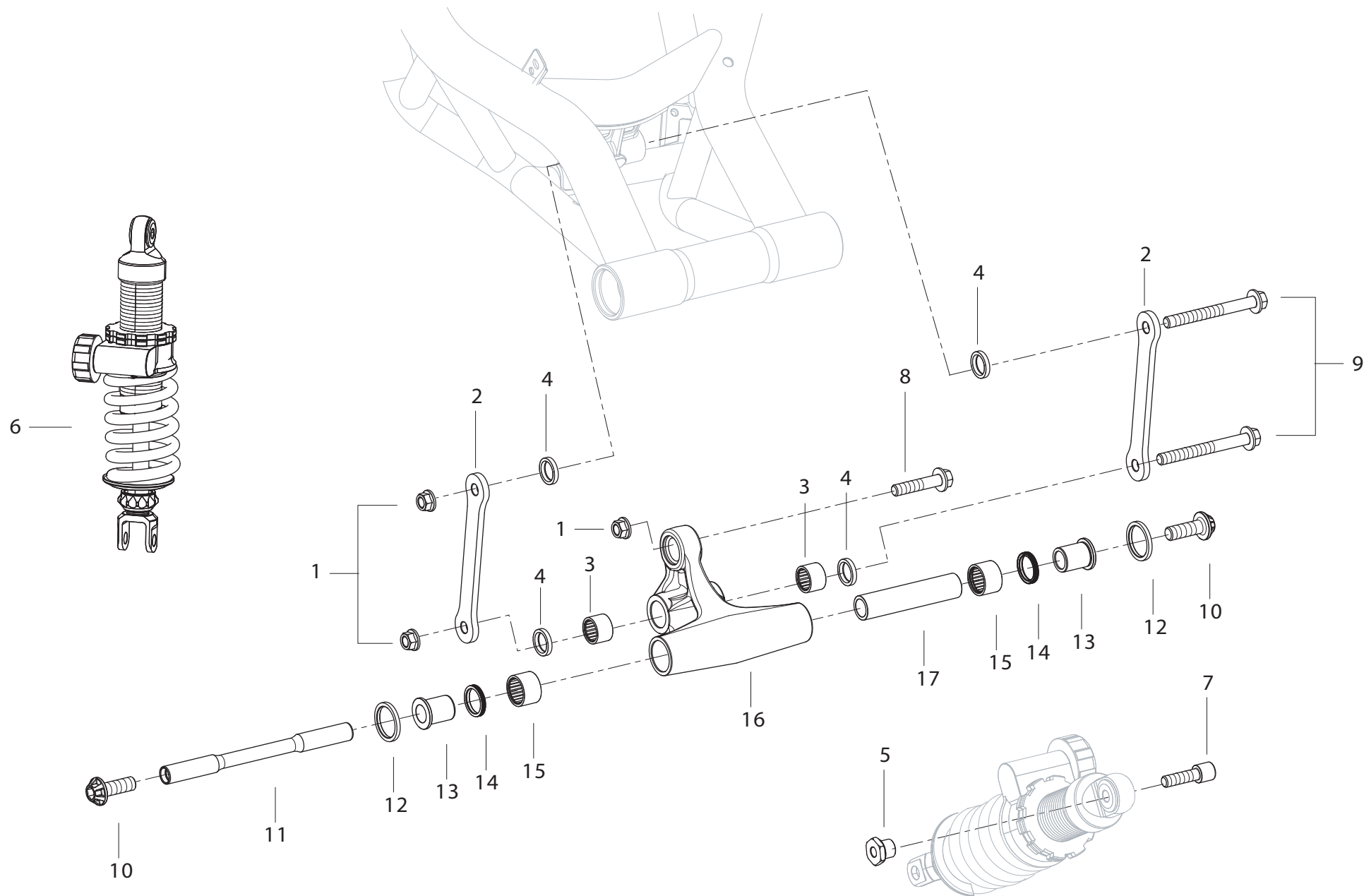

POS. NO. N. INDEX POS.	N. CODICE CODE NO. Nr. CODE ATRIKEL Nr. CODICO Nr.	DESCRIZIONE	DESCRIPTION	DESIGNATION	BEZEICHNUNG	DENOMINACION	NOTE NOTES NOTES MARKE NOTAS	Q.TA' Q.TY Q.TE M.GE C.AD	
1	R91350092B	DADO	NUT	ECROU	MUTTER	TUERCA		3	
2	R21313311A	BIELLETTA	CONNECTING ROD	BIELLETTA	PLEUELSTANGE	BIELA		2	
3	R21215011A	CUSCINETTO A RULLI	ROLLER BEARING	COUSSINET A ROULEAUX	ROLLENLAGER	COJINETE RODILLOS		2	
4	R21813741A	ANELLO DI TENUTA	SEAL RING	BAGUE D'ÉTANCHÉITÉ	DICHTRING	ANILLO DE RETÉN		4	
5	R90750142B	DADO	NUT	ECROU	MUTTER	TUERCA		1	
6	R310070100000	AMMORTIZZATORE	SHOCK ABSORBER	AMORTISSEUR	STOßDÄMPFER	AMORTIGUADOR		1	
7	R90750092B	VITE	SCREW	VIS	SCHRAUBE	TORNILLO		1	
8	R21214771A	VITE	SCREW	VIS	SCHRAUBE	TORNILLO		1	
9	R21214701A	VITE	SCREW	VIS	SCHRAUBE	TORNILLO		2	
10	R310070184000	VITE	SCREW	VIS	SCHRAUBE	TORNILLO		2	
11	R310070183000	PERNO	PIN	PIVOT	ZAPFEN	PERNO		1	
12	R310070191000	RONDELLA	WASHER	RONDELLE	UNTERLEGSCHIEBE	ARANDELA		2	
13	R310070182000	BOCCOLA	BUSH	DOUILLE	BUCHSE	CASQUILLO		2	
14	R310070189000	ANELLO DI TENUTA	SEAL RING	BAGUE D'ÉTANCHÉITÉ	DICHTRING	ANILLO DE RETÉN		2	
15	R310070190000	CUSCINETTO A RULLI	ROLLER BEARING	COUSSINET A ROULEAUX	ROLLENLAGER	COJINETE RODILLOS		2	
16	R310070116000	BILANCIERE	ROCKER	CULBUTEUR	AUSBALANCIEREN	BILANCÍN		1	
17	R310070185000	DISTANZIALE	SPACER	ENTRETOISE	DISTANZSTÜCK	DISTANCIAL		1	

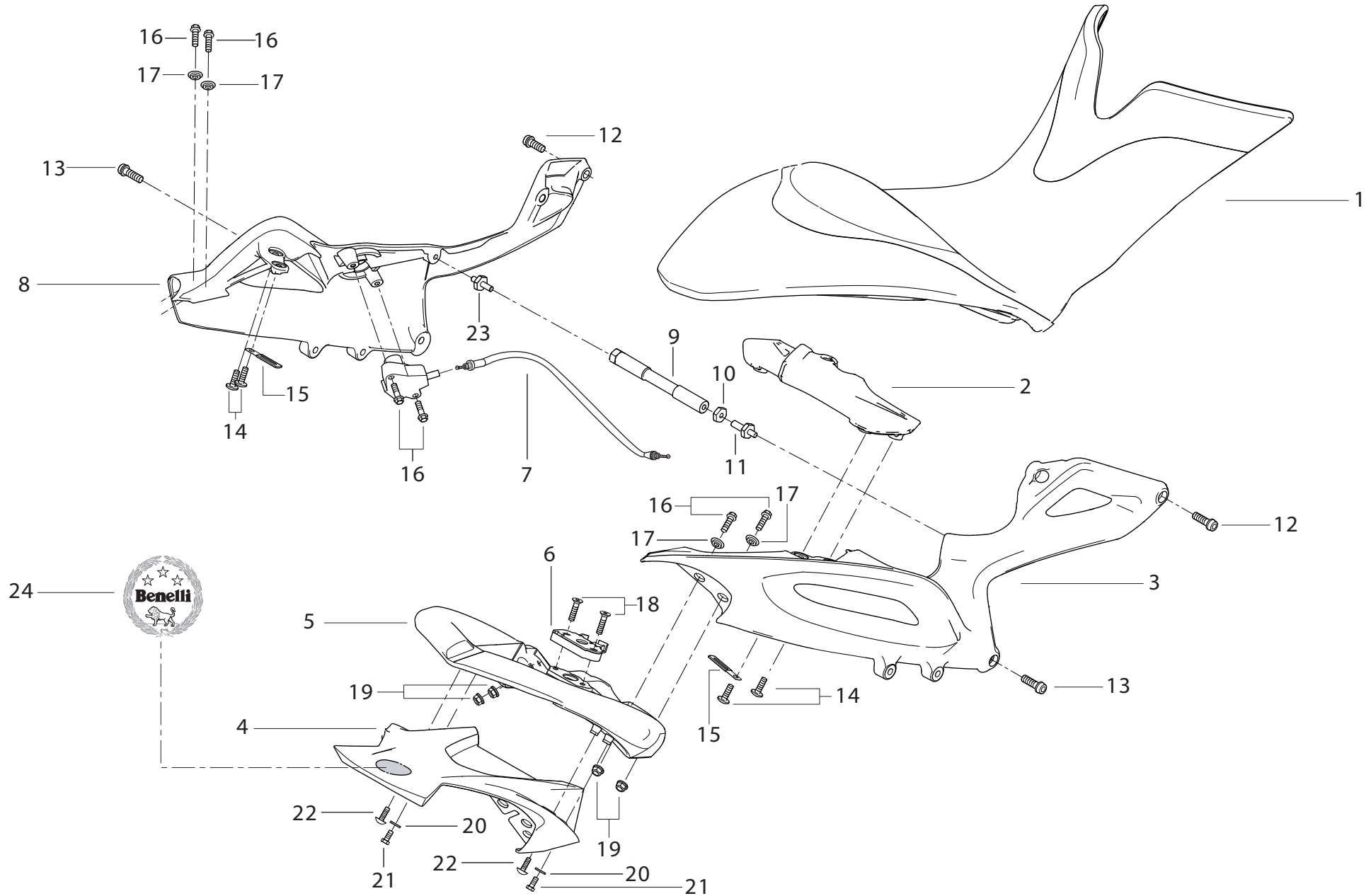

POS. NO. N. INDEX POS.	N. CODICE CODE NO. Nr. CODE ATRIKEL Nr. CODICO Nr.	DESCRIZIONE	DESCRIPTION	DESIGNATION	BEZEICHNUNG	DENOMINACION	NOTE NOTES NOTES MARKE NOTAS	Q.TA' Q.TY Q.TE M.GE C.AD	
1	R310075003000	SELLA	SEAT	SIEGE	SATTEL	SILLIN		1	
2	R30015000900X	TRAVERSO POSTERIORE	BACK SPRING	TRAVERSE ARRIÈRE	HINTERE QUERSTANGE	TRAVESERO TRASERO		1	
3	R31005000800X	TELAIETTO POSTERIORE DX (NERO)	REAR R.H. FRAME (BLACK)	CADRE ARRIÈRE DROITE (NOIR)	HINTERER RAHMEN RECHT (SCHWARZ)	CHASSIS TRASERO DER. (NEGRO)		1	
4	R310074190000	CODONE	TAIL GUARD	CORPS DE SELLE	HECK	CUERPO ASIEN TO	AMAZONAS	1	
5	R31005000200X	MANIGLIA	HANDLE	POIGNÉE	HANDGRIFF	MANILLA		1	
6	R180266102000	LEVA APERTURA SELLA	SEAT LEVER	LEVIER DE SELLE	SITZBANKHEBEL	PALANCA ABERTURA SILLÍN		1	
7	R310066126000	COMANDO FLESSIBILE	FLEXIBLE CONTROLL	COMMANDE FLEXIBLEL	SEILSTEUERUNGL	MANDO FLEXIBLE		1	
8	R31005000700X	TELAIETTO POSTERIORE SX (NERO)	REAR L.H. FRAME (BLACK)	CADRE ARRIÈRE GAUCHE (NOIR)	HINTERER RAHMEN LINKS (SCHWARZ)	CHASSIS TRASERO IZQ. (NEGRO)		1	
9	R300050018000	COLONNETTA	STUD BOLT	GOUJON	STIFTSCHRAUBE	ESPÁRRAGO		1	
10	R90752992B	DADO SPECIALE	SPECIAL NUT	ECROU SPÉCIALE	SPEZIALMUTTER	TUERCA ESPECIAL		1	
11	R300015014000	VITE SPECIALE DX	R.H. SPECIAL SCREW	VIS SPÉCIALE DROITE	SPEZIALSCHRAUBE RECHTS	TORNILLO ESPECIAL DER.		1	
12	R90751432B	VITE	SCREW	VIS	SCHRAUBE	TORNILLO		2	
13	R90751452B	VITE	SCREW	VIS	SCHRAUBE	TORNILLO		2	
14	R90752162B	VITE	SCREW	VIS	SCHRAUBE	TORNILLO		4	
15	R300068104000	FASCETTA IN GOMMA	RUBBER HOSE CLAMP	COLLIER EN CAOUTCHOUC	GUMMISCHELLE	ABRAZADERA EN GOMA		2	
16	R90750672B	VITE	SCREW	VIS	SCHRAUBE	TORNILLO		6	
17	R310079007000	BOCCOLA	BUSH	DOUILLE	BUCHSE	CASQUILLO		4	
18	R90650542B	VITE	SCREW	VIS	SCHRAUBE	TORNILLO		2	
19	R91350072B	DADO	NUT	ECROU	MUTTER	TUERCA		4	
20	R92050152B	RONDELLA	WASHER	RONDELLE	UNTERLEGSCHIEBE	ARANDELA		2	
21	R91050392B	VITE	SCREW	VIS	SCHRAUBE	TORNILLO		2	
22	R90750182B	VITE	SCREW	VIS	SCHRAUBE	TORNILLO		2	
23	R300015015000	VITE SPECIALE SX	L.H. SPECIAL SCREW	VIS SPÉCIALE GAUCHE	SPEZIALSCHRAUBE LINKS	TORNILLO ESPECIAL IZQ.		1	
24	R030493003000	ADESIVO BENELLI (Ø40)	BENELLI STICKER (Ø40)	DÉCALCOMANIE BENELLI (Ø40)	AUFKLEBER BENELLI (Ø40)	ADHESIVO BENELLI (Ø40)		1	

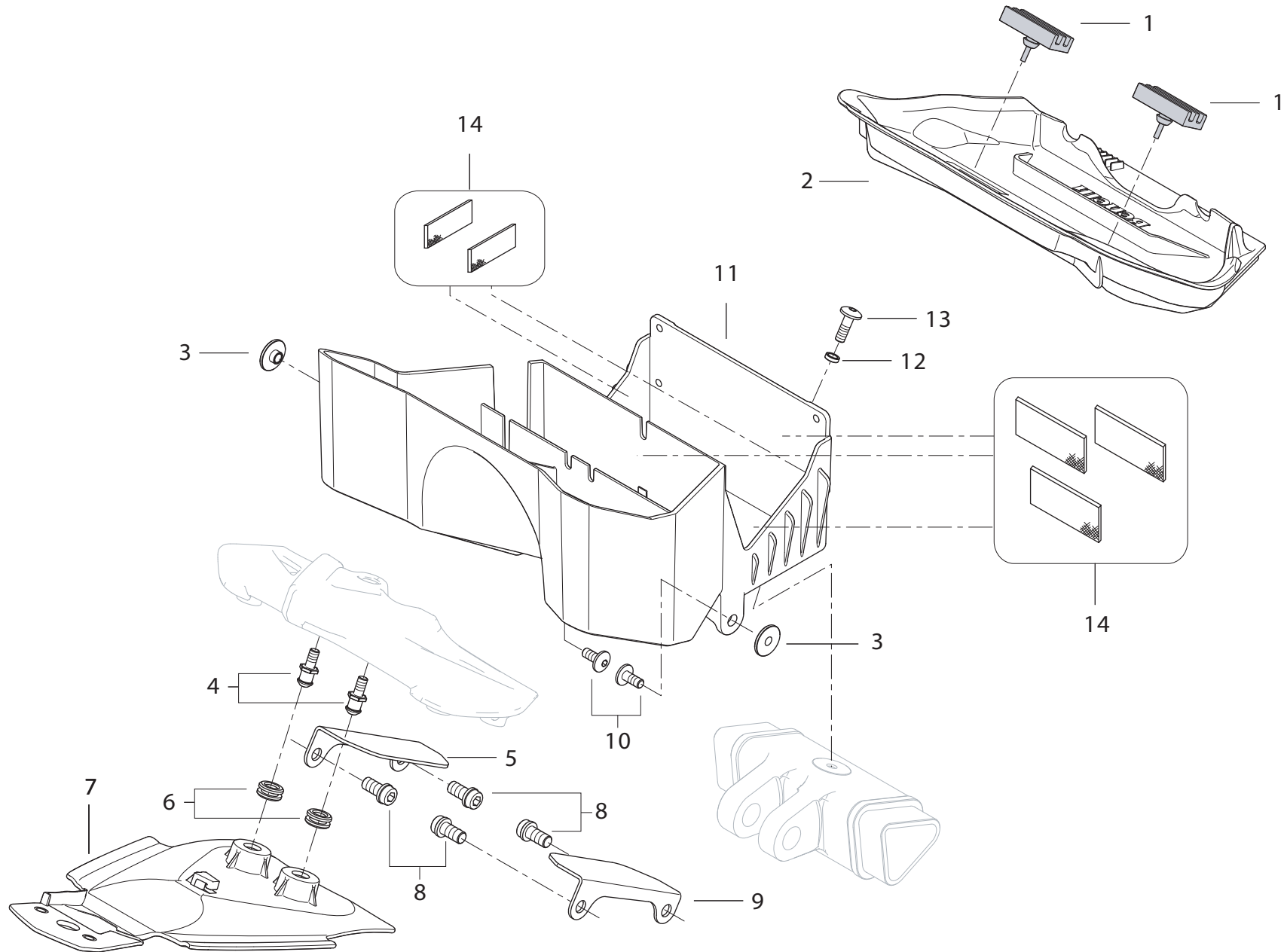



SCATOLA BATTERIA



BATTERY BOX



BOÎTE BATTERIE



BATTERIEGEHÄUSE



CAJA BATERÍA

POS. NO. N. INDEX POS.	N. CODICE CODE NO. Nr. CODE ATRIKEL Nr. CODICO Nr.	DESCRIZIONE	DESCRIPTION	DESIGNATION	BEZEICHNUNG	DENOMINACION	NOTE NOTES NOTES MARKE NOTAS	Q.TA' Q.TY Q.TE M.GE C.AD	
1	R300079189000	TAMPONE	PAD	TAMPON	STOPFEN	APOYO		2	
2	R300074211000	COPERCHIO	COVER	COUVERCLE	DECKEL	TAPA		1	
3	R310079188000	BOCCOLA	BUSH	DOUILLE	BUCHSE	CASQUILLO		2	
4	R300052003000	VITE SPECIALE	SPECIAL SCREW	VIS SPÉCIALE	SCHRAUBE	TORNILLO ESPECIAL		2	
5	R300057005000	STAFFA SX	L.H. BRACKET	BRIDE GAUCHE	LINKER BÜGEL	SOPORTE IZQ.		1	
6	R100279118000	GOMMINO ANTIVIBRANTE	VIBRATION DAMPER PAD	JOINT EN CAOUTCHOUC ANTI-VIBRATION	SCHWINGUNGSDÄMPFERGUMMI	JUNTA DE GOMA ANTI-VIBRACIÓN		2	
7	R300091006000	COPERCHIO PARACALORE	HEAT GUARD COVER	COUVERCLE PARE-CHALEUR	DECKEL WÄRMESCHUTZ	TAPA PROTECCIÓN CALOR		1	
8	R90751422B	VITE	SCREW	VIS	SCHRAUBE	TORNILLO		4	
9	R300057006000	STAFFA DX	R.H. BRACKET	BRIDE DROITE	RECHTER BÜGEL	SOPORTE DER.		1	
10	RR90752032B	VITE	SCREW	VIS	SCHRAUBE	TORNILLO		2	
11	R300074210001	SCATOLA SUPPORTO BATTERIA	BATTERY BOX MOUNT	SUPPORT BOÎTE BATTERIE	BATTERIEHALTERUNG	SOPORTE CAJA BATERÍA		1	
12	R90752972B	BOCCOLA	BUSH	DOUILLE	BUCHSE	CASQUILLO		1	
13	R90752162B	VITE	SCREW	VIS	SCHRAUBE	TORNILLO		1	
14	R51840091AZ	ANTIVIBRANTE	VIBRATION DAMPER	ANTIVIBRATION	SCHWINGUNGSDÄMPFER	ANTI-VIBRACIÓN		5	

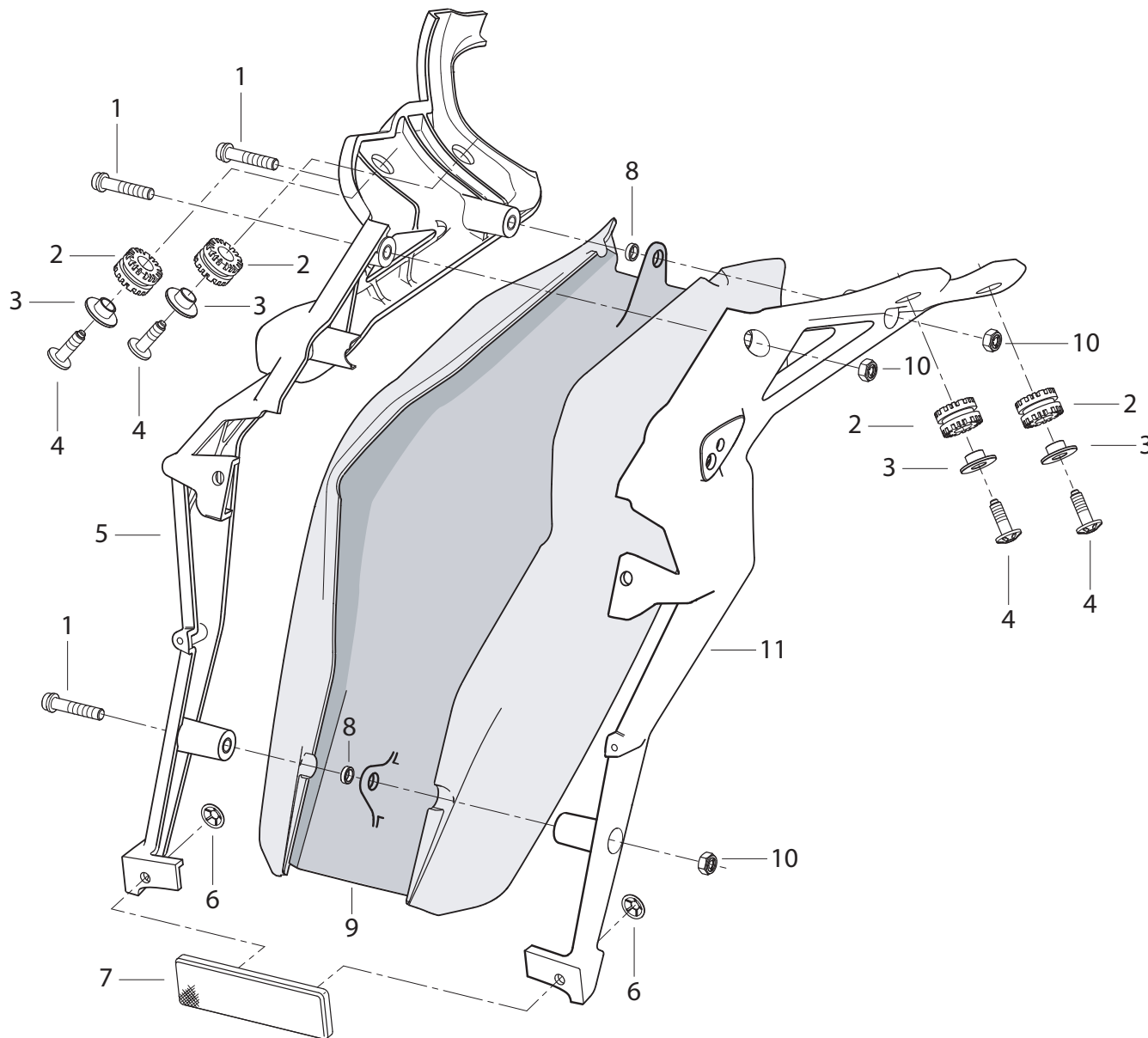

POS. NO. N. INDEX POS.	N. CODICE CODE NO. Nr. CODE ATRIKEL Nr. CODICO Nr.	DESCRIZIONE	DESCRIPTION	DESIGNATION	BEZEICHNUNG	DENOMINACION	NOTE NOTES MARKE NOTAS	Q.TA' Q.TY Q.TE M.GE C.AD	
1	R90750532B	VITE	SCREW	VIS	SCHRAUBE	TORNILLO		3	
2	R180479181000	GOMMINO	RUBBER PAD	JOINT EN CAOUTCHOUC	GUMMISTÜCK	JUNTA DE GOMA		4	
3	R300079194000	BOCCOLA	BUSH	DOUILLE	BUCHSE	CASQUILLO		4	
4	R90750198E	VITE	SCREW	VIS	SCHRAUBE	TORNILLO		4	
5	R300074215000	PORTATARGA SX	L.H. NUMBER PLATE HOLDER	PORTE-PLAQUE GAUCHE	LINKS NUMMERSCHILDTAFEL	PORTA-MATRÍCULA IZQ.		1	
6	R95050091A	ROSETTA	WASHER	ROSETTE	UNTERLEGSSCHEIBE	ARANDELA		2	
7	R52840041A0	CATADIOTTRO	REFLECTOR	CATADIOPTRE	RÜCKSTRAHLER	CATADI ÓPTICO		1	
8	R90752972B	BOCCOLA	BUSH	DOUILLE	BUCHSE	CASQUILLO		1	
9	R310074235000	PARAFANGO POSTERIORE	REAR MUDGUARD	GARDE-BOUE AR.	HINTERERS SCHUTZBLECH	GUARDABARROS TRASERO		1	
10	R91750032B	DADO	NUT	ECROU	MUTTER	TUERCA		3	
11	R300074216000	PORTATARGA DX	R.H. NUMBER PLATE HOLDER	PORTE-PLAQUE DROITE	RECHTS NUMMERSCHILDTAFEL	PORTA-MATRÍCULA DER.		1	

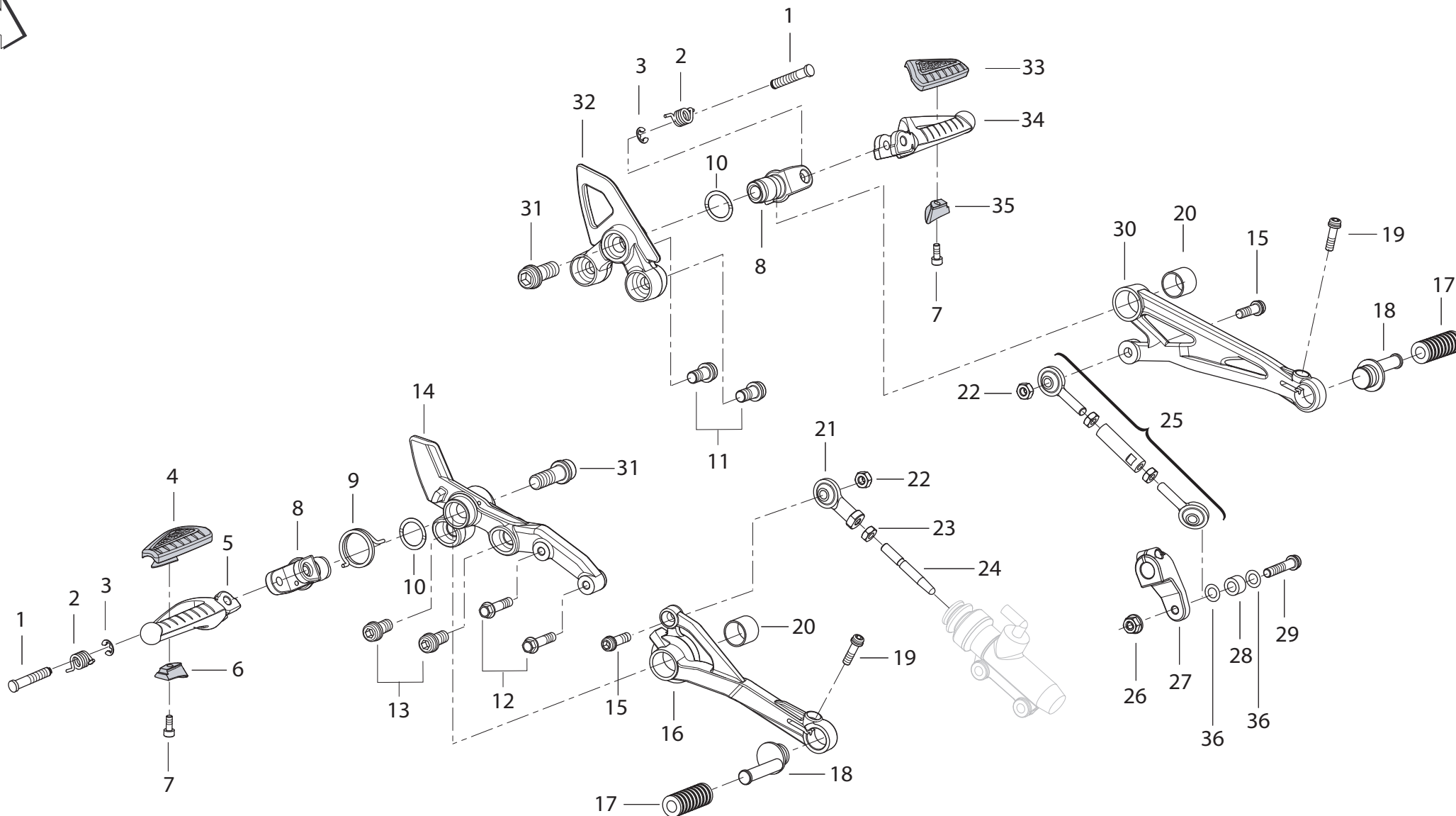



PEDANE ANTERIORI



FRONT FOOT PEG



REPOSE PIEDS AVANT



VORDERE FUSSRASTE



ESTRIBERAS DELANTERA

POS. NO. N. INDEX POS.	N. CODICE CODE NO. Nr. CODE ATRIKEL Nr. CODICO Nr.	DESCRIZIONE	DESCRIPTION	DESIGNATION	BEZEICHNUNG	DENOMINACION	NOTE NOTES NOTES MARKE NOTAS	Q.TA' Q.TY Q.TE M.GE C.AD	
1	R21215031A	PERNO	PIN	PIVOT	ZAPFEN	PERNO		2	
2	R21215121A	MOLLA	SPRING	RESSORT	FEDER	MUELLE		2	
3	R92650088D	ANELLO SEEGER	CIRCLIP	CIRCLIP	SEEGERRING	ANILLO SEEGER		2	
4	R300358030000	GOMMINO	RUBBER PAD	JOINT EN CAOUTCHOUC	GUMMISTÜCK	JUNTA DE GOMA		1	
5	R21813801A	PEDANA ANTERIORE DX	FRONT R.H. FOOT PEG	REPOSE-PIED AVANT DROIT	VORDERE RECHTE FUSSRASTE	ESTRIBERA DELANTERA DER.		1	
6	R300358026000	GOMMINO FISSAGGIO DX	R.H. FASTENING RUBBER PAD	JOINT EN CAOUTCHOUC FIXATION DROITE	BEFESTIGUNG GUMMISTÜCK RECHTE	JUNTA DE GOMA FIJACIÓN DER.		1	
7	R90250188E	VITE	SCREW	VIS	SCHRAUBE	TORNILLO		2	
8	R310058031000	FORCHETTA	FORK	FOURCHE	GABEL	HORQUILLA		2	
9	R300059000000	MOLLA	SPRING	RESSORT	FEDER	MUELLE		1	
10	R21215391A	RONDELLA ELASTICA	SPRING WASHER	RONDELLE ÉLASTIQUE	ELASTISCHER UNTERLEGSCHIEBE	ARANDELA ELÁSTICA		2	
11	R16343531A	VITE	SCREW	VIS	SCHRAUBE	TORNILLO		2	
12	R90750692B	VITE	SCREW	VIS	SCHRAUBE	TORNILLO		2	
13	R90751512B	VITE	SCREW	VIS	SCHRAUBE	TORNILLO		2	
14	R310058000000	PIASTRA PORTA PEDANA ANTERIORE DX	FRONT R.H. FOOT PEG HOLDER PLATE	PLAQUE PORTE-REPOSE-PIED AVANT DROITE	PLATTE FÜR FUßRASTENHALTER VORDERES RECHTER	SOPORTE ESTRIBERA DELANTERO DER.		1	
15	R90750512B	VITE	SCREW	VIS	SCHRAUBE	TORNILLO		2	
16	R310059005000	LEVA COMANDO FRENO	BRAKE CONTROL LEVER	LEVIER DE COMMANDE FREIN	BREMSHEBEL	LEVA MANDO FRENO		1	
17	R300158022000	GOMMINO	RUBBER PAD	JOINT EN CAOUTCHOUC	GUMMISTÜCK	JUNTA DE GOMA		2	
18	R310058021000	ECCENTRICO PUNTALINO	RUNNER ECCENTRIC	EXCENTRIQUE BUTÉE	EXZENTERNABE TASTBOLZEN	EXCÉNTRICO TRINQUETE		2	
19	R90750422B	VITE	SCREW	VIS	SCHRAUBE	TORNILLO		2	
20	R21215081A	BOCCOLA	BUSH	DOUILLE	BUCHSE	CASQUILLO		2	
21	R21813851A	SNODO SFERICO	BALL JOINT	JOINT À ROTULE	KUGELGELENK	ARTICULACIÓN ESFERICA		1	
22	R91750032B	DADO	NUT	ECROU	MUTTER	TUERCA		2	
23	R91551022B	DADO	NUT	ECROU	MUTTER	TUERCA		1	
24	R21215041A	ASTA DI REGISTRO	ADJUSTER ROD	TIGE DE RÉGLAGE	EINSTELLSTAB	VORILLA DE REGULACIÓN		1	

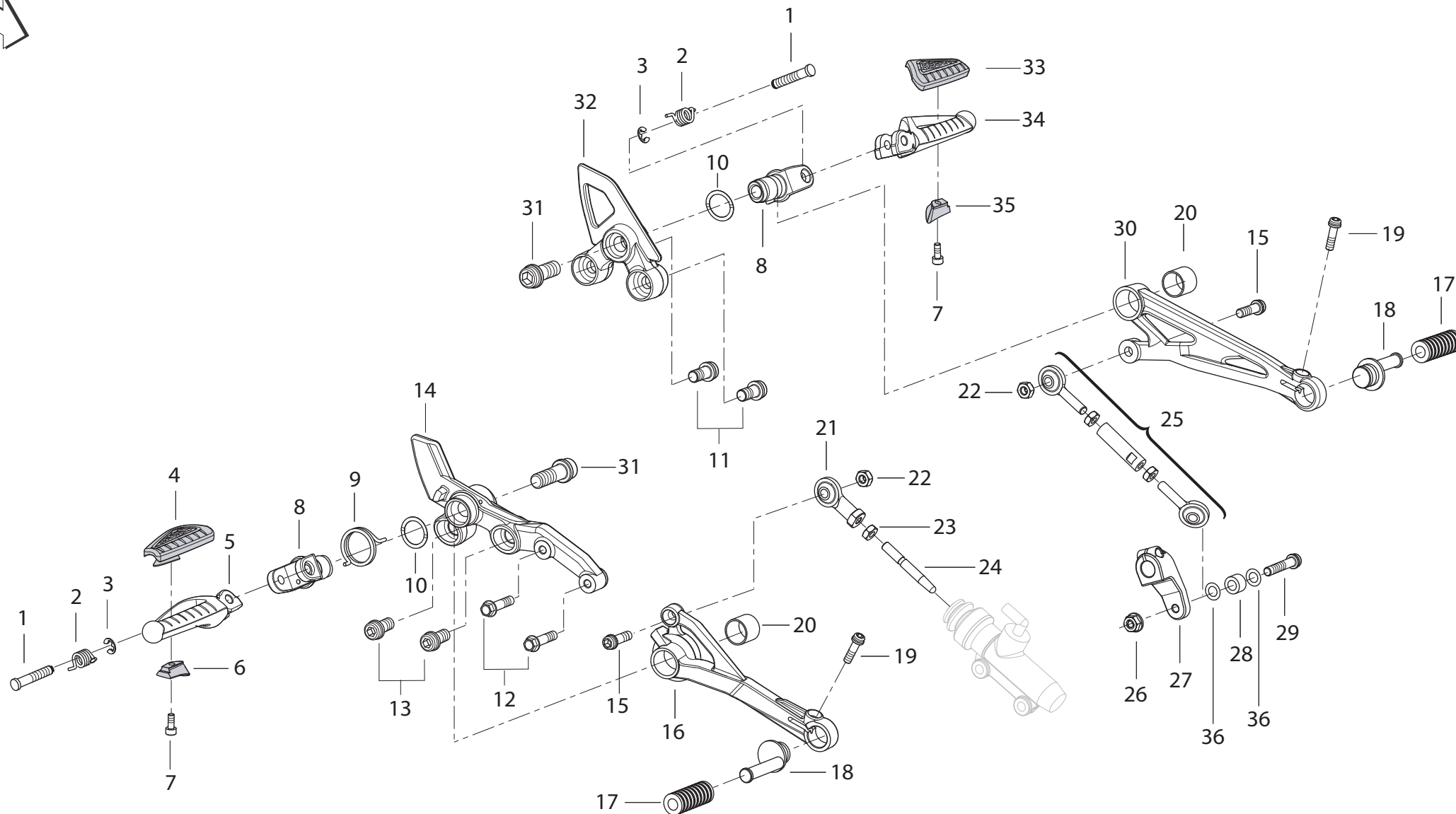



PEDANE ANTERIORI



FRONT FOOD PEG



REPOSE PIEDS AVANT



VORDERE FUSSRASTE



ESTRIBERAS DELANTERA

POS. NO. N. INDEX POS.	N. CODICE CODE NO. Nr. CODE ATRIKEL Nr. CODICO Nr.	DESCRIZIONE	DESCRIPTION	DESIGNATION	BEZEICHNUNG	DENOMINACION	NOTE NOTES NOTES MARKE NOTAS	Q.TA' Q.TY Q.TE M.GE C.AD	
25	R310099011000	ASSIEME ASTA RINVIO CAMBIO	GEARBOX TRANSMISSION ROD ASSEMBLY	ENSEMBLE TIGE RENVOI BOÎTE DE VITESSES	GRUPPE STAB FÜR WECHSELGETRIEBEVORGELEGE	GRUPO VARILLA REENVÍO CAMBIO		1	
26	R91350072B	DADO	NUT	ECROU	MUTTER	TUERCA		1	
27	R21813811A	LEVETTA COMANDO CAMBIO	GEARCHANGE CONTROL LEVER	LEVIER DE COMMANDE VITESSES	SCHALTHEBEL	LEVA MANDO CAMBIO		1	
28	R310058037000	DISTANZIALE	SPACER	ENTRETOISE	DISTANZSTÜCK	DISTANCIADOR INTERIOR		1	
29	R90750532B	VITE	SCREW	VIS	SCHRAUBE	TORNILLO		1	
30	R310058008000	LEVA COMANDO CAMBIO	GEARCHANGE LEVER	LEVIER DE COMMANDE VITESSES	SCHALTHEBEL	LEVA MANDO CAMBIO		1	
31	R90753082B	VITE	SCREW	VIS	SCHRAUBE	TORNILLO		2	
32	R310058001000	PIASTRA PORTA PEDANA ANTERIORE SX	FRONT L.H. FOOT PEG HOLDER PLATE	PLAQUE PORTE-REPOSE-PIED AVANT GAUCHE	PLATTE FÜR FUßRASTENHALTER VORDERES LINKS	SOPORTE ESTRIBERA DELANTERO IZQ.		1	
33	R300358025000	GOMMINO	RUBBER PAD	JOINT EN CAOUTCHOUC	GUMMISTÜCK	JUNTA DE GOMA		1	
34	R21813791A	PEDANA ANTERIORE SX	FRONT L.H. FOOT PEG	REPOSE-PIED AVANT GAUCHE	VORDERE LINKE FUSSRASTE	ESTRIBERA DELANTERA IZQ.		1	
35	R300358029000	GOMMINO FISSAGGIO SX	L.H. FASTENING RUBBER PAD	JOINT EN CAOUTCHOUC FIXATION GAUCHE	BEFESTIGUNG GUMMISTÜCK LINK	JUNTA DE GOMA FIJACIÓN IZQ.		1	
36	R92050152B	RONDELLA	WASHER	RONDELLE	UNTERLEGSSCHEIBE	ARANDELA		2	



PEDANE POSTERIORI



REAR FOOT PEG



REPOSE PIED ARRIÈRE



HINTERE FUSSRASTE



ESTRIBERAS TRASERA

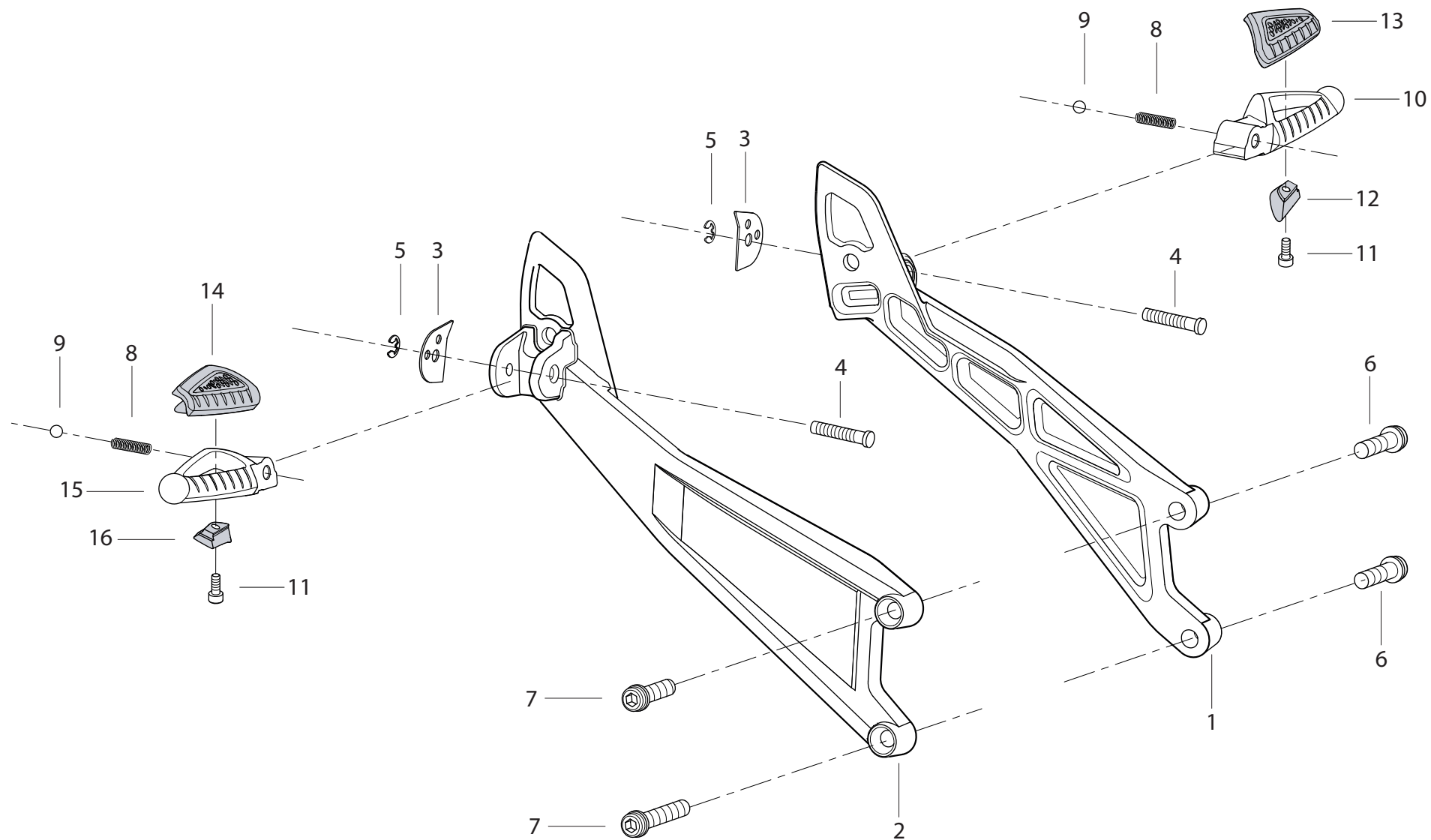



PEDANE POSTERIORI



REAR FOOT PEG



REPOSE PIED ARRIÈRE



HINTERE FUSSRASTE



ESTRIBERAS TRASERA

POS. NO. N. INDEX POS.	N. CODICE CODE NO. Nr. CODE ATRIKEL Nr. CODICO Nr.	DESCRIZIONE	DESCRIPTION	DESIGNATION	BEZEICHNUNG	DENOMINACION	NOTE NOTES NOTES MARKE NOTAS	Q.TA' Q.TY Q.TE M.GE C.AD	
1	R31005800500X	PIASTRA PORTAPEDANA SX	L.H. FOOT PEG HOLDER PLATE	PLAQUE PORTE-REPOSE-PIED GAUCHE	PLATTE FÜR FUßRASTENHALTER LINKER	SOPORTE ESTRIBERA IZQ.		1	
2	R31005800600X	PIASTRA PORTAPEDANA DX	R.H. FOOT PEG HOLDER PLATE	PLAQUE PORTE-REPOSE-PIED DROITE	PLATTE FÜR FUßRASTENHALTER RECHER	SOPORTE ESTRIBERA DER.		1	
3	R180258007000	PIASTRINO	PLATE	PLAQUETTE	PLÄTTCHEN	LÁMINA		2	
4	R21215031A	PERNO	PIN	PIVOT	ZAPFEN	PERNO		2	
5	R92650088D	ANELLO ELASTICO	SNAP RING	BAGUE ÉLASTIQUE	SPRENGRING	SEAGER		2	
6	R90751462B	VITE	SCREW	VIS	SCHRAUBE	TORNILLO		2	
7	R90751492B	VITE	SCREW	VIS	SCHRAUBE	TORNILLO		2	
8	R26110091A	MOLLA	SPRING	RESSORT	FEDER	MUELLE		2	
9	R26110101A	SFERA	BALL	BILLE	KUGEL	ESFERA		2	
10	R180258003000	PEDANA POSTERIORE SX	REAR L.H. FOOT PEG	REPOSE-PIED AR. GAUCHE	HINTERE FUSSRASTE LINKS	ESTRIBERA TRASERA IZQ.		1	
11	R90250188E	VITE	SCREW	VIS	SCHRAUBE	TORNILLO		2	
12	R300358029000	FERMO GOMMA PEDANA SX	L.H. FIXED RUBBER	LE CAOUTCHOUC FIXE GAUCHE	ÖRTLICH FESTGELEGTER GUMMI GAUCHE	CAUCHO FIJO IZQ.		1	
13	R300358025000	COPRIPEDANA IN GOMMA SX	L.H. FOOT PEG RUBBER COVER	COUVRE-REPOSE-PIED EN CAOUTCHOUC GAUCHE	FUßSTÜTZENVERKLEIDUNG AUS GUMMI LINKER	COBERTURA APOYA-PIES DE GOMA IZQ.		1	
14	R300358030000	COPRIPEDANA IN GOMMA DX	R.H. FOOT PEG RUBBER COVER	COUVRE-REPOSE-PIED EN CAOUTCHOUC DROITE	FUßSTÜTZENVERKLEIDUNG AUS GUMMI RECHTER	COBERTURA APOYA-PIES DE GOMA DER.		1	
15	R180258004000	PEDANA POSTERIORE DX	REAR R.H. FOOT PEG	REPOSE-PIED AR. DROITE	HINTERE FUSSRASTE RECHTS	ESTRIBERA TRASERA DER.		1	
16	R300358026000	FERMO GOMMA PEDANA DX	R.H. FIXED RUBBER	LE CAOUTCHOUC FIXE DROITE	ÖRTLICH FESTGELEGTER GUMMI RECHTER	CAUCHO FIJO DER.		1	

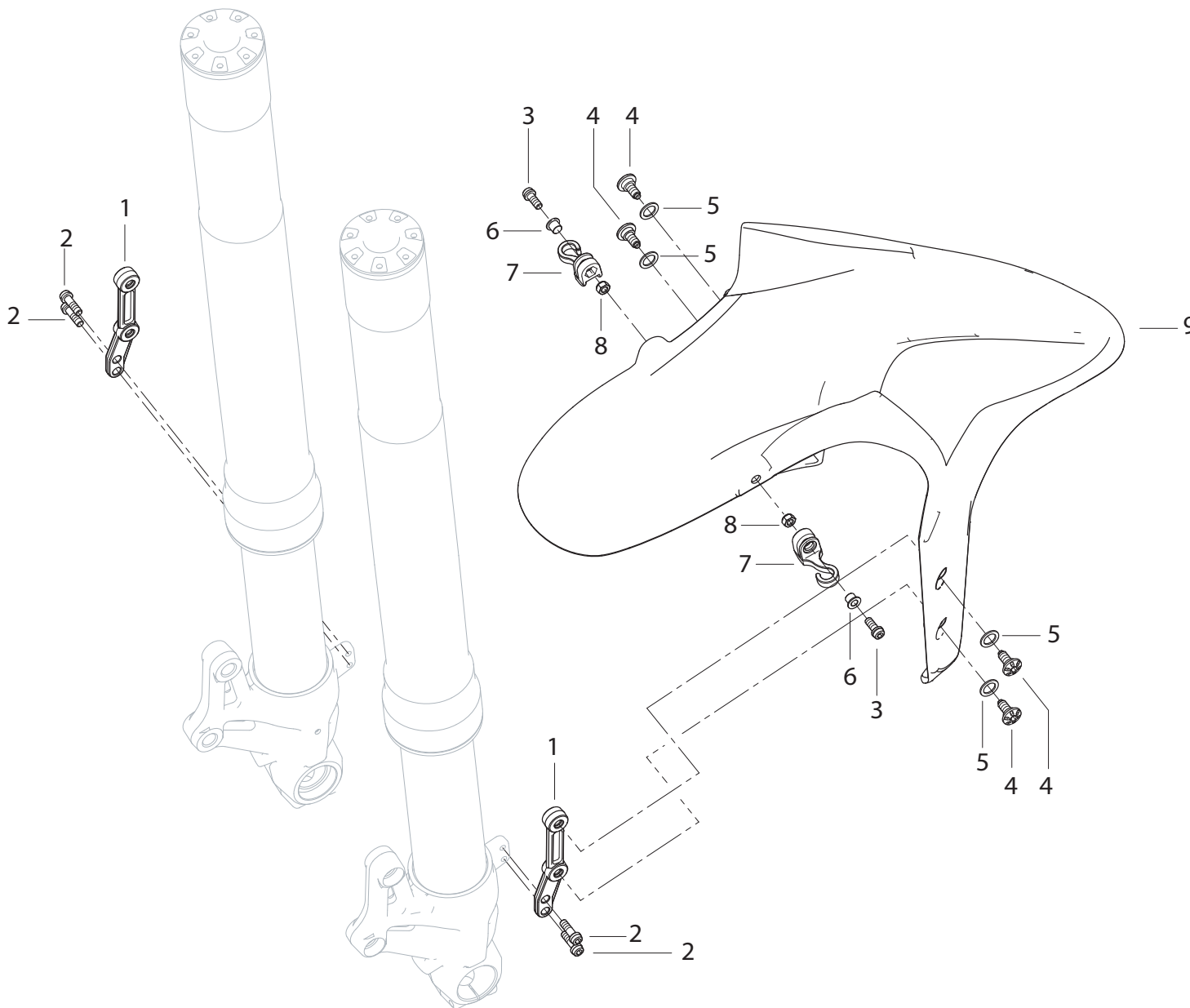

POS. NO. N. INDEX POS.	N. CODICE CODE NO. Nr. CODE ATRIKEL Nr. CODICO Nr.	DESCRIZIONE	DESCRIPTION	DESIGNATION	BEZEICHNUNG	DENOMINACION	NOTE NOTES NOTES MARKE NOTAS	Q.TA' Q.TY Q.TE M.GE C.AD	
1	R180257138000	STAFFA	BRACKET	BRIDE	BÜGEL	SOPORTE		2	
2	R90750412B	VITE	SCREW	VIS	SCHRAUBE	TORNILLO		4	
3	R90750392B	VITE	SCREW	VIS	SCHRAUBE	TORNILLO		2	
4	R90752268E	VITE SPECIALE	SPECIAL SCREW	VIS SPÉCIALE	SPEZIALSCHRAUBE	TORNILLO ESPECIAL		4	
5	R90752302B	ROSETTA NYLON	NYLON WASHER	ROSETTE EN NYLON	NYLON-UNTERLEGSCHIEBE	ARANDELA NYLON		4	
6	R310079200000	BOCCOLA A "T"	BUSH	DOUILLE	BUCHSE	CASQUILLO		2	
7	R310068102000	PASSATUBO	HOSE GUIDE	PASSE-TUBE	LEITUNGSFÜHRUNG	PASATUBO		2	
8	R91750022B	DADO	NUT	ECROU	MUTTER	TUERCA		2	
9	R3100741390CL	PARAFANGO ANTERIORE (NERO)	FRONT MUDGUARD (BLACK)	GARDE-BOUE AVANT (NOIR)	VORDERES SCHUTZBLECH (SCHWARZ)	GUARDABARROS DELANTERO (NEGRO)		1	
9	R3100741390CW	PARAFANGO ANTERIORE (VERDE)	FRONT MUDGUARD (GREEN)	GARDE-BOUE AVANT (VERT)	VORDERES SCHUTZBLECH (GRÜN)	GUARDABARROS DELANTERO (VERDE)		1	



FORCELLA ANTERIORE



FRONT FORK



FOURCHE AVANT



TELEGABEL



HORQUILLA DELANTERA

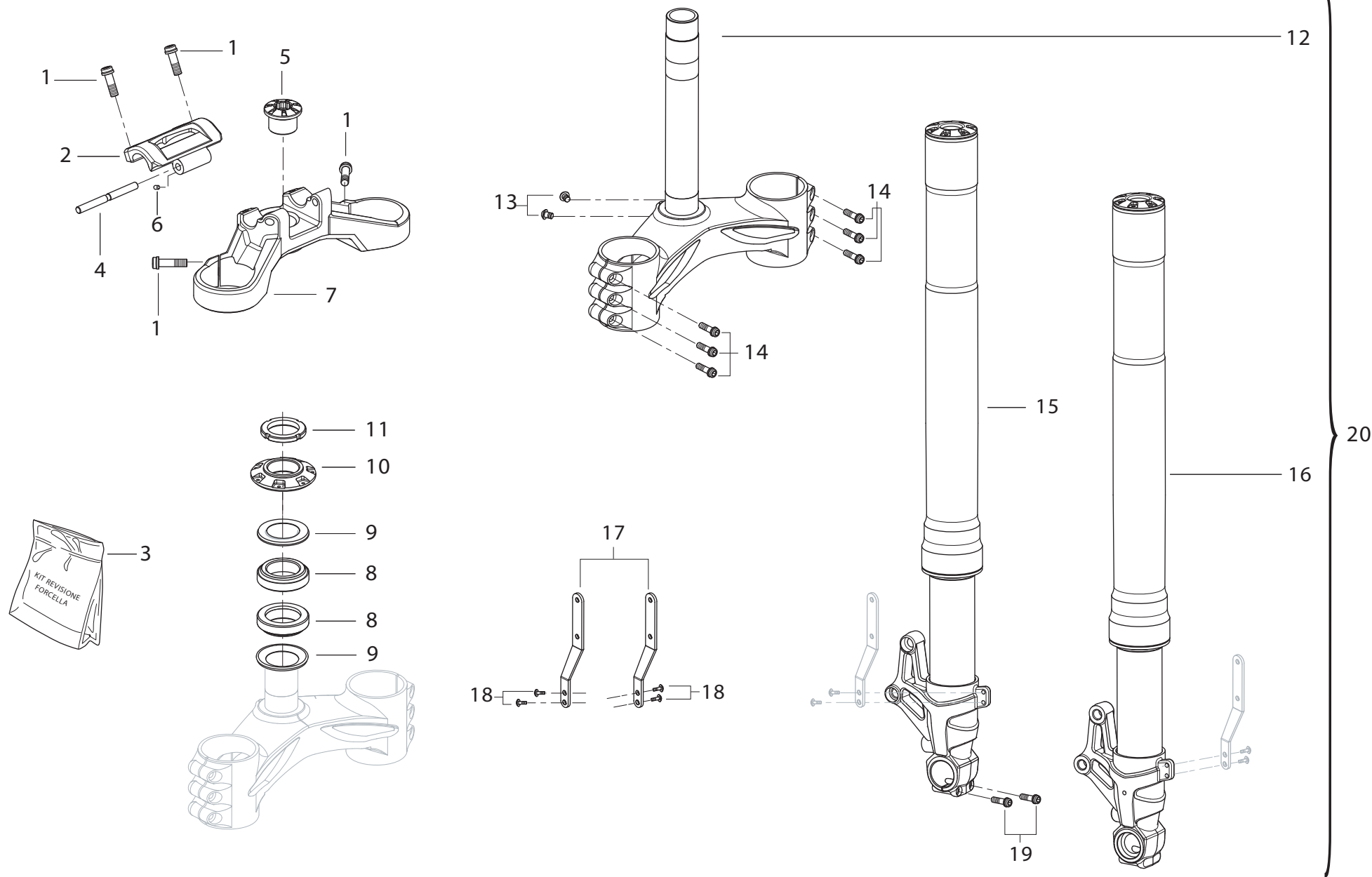



FORCELLA ANTERIORE



FRONT FORK



FOURCHE AVANT



TELEGABEL



HORQUILLA DELANTERA

POS. NO. N. INDEX POS.	N. CODICE CODE NO. Nr. CODE ATRIKEL Nr. CODICO Nr.	DESCRIZIONE	DESCRIPTION	DESIGNATION	BEZEICHNUNG	DENOMINACION	NOTE NOTES NOTES MARKE NOTAS	Q.TA' Q.TY Q.TE M.GE C.AD	
1	R90751452B	VITE	SCREW	VIS	SCHRAUBE	TORNILLO		4	
2	R31006902100X	CAVALLOTTO MANUBRIO	HANDLEBAR BRACKET	CAVALIER GUIDON	BÜGELBOLZEN LENKER	PERNO DE U		1	
3	R300000157000	KIT REVISIONE FORCELLA	FORK OVERHAUL KIT	KIT RÉVISION FOURCHE	REPARATURKIT TELEGABEL	KIT REVISIÓN HORQUILLA		1	
4	R300052008000	PERNO	PIN	PIVOT	ZAPFEN	PERNO		1	
5	R21413141A	VITE SPECIALE	SPECIAL SCREW	VIS SPÉCIALE	SPEZIALSCHRAUBE	TORNILLO ESPECIAL		1	
6	R92950352B	GRANO	DOWEL	VIS SANS TÊTE	STIFT	CLAVIJA		1	
7	R30036900700X	TESTA DI STERZO	STEERING HEAD	TÊTE DE DIRECTION	GABELKOPF	TIJA SUPERIOR		1	
8	R21413021A	CUSCINETTO	BEARING	ROULEMENT	LAGER	COJINETE		2	
9	R21413031A	ANELLO PARAPOLVERE	DUST PROTECTION RING	PARE-POUSSIÈRE	STAUBSCHUTZRING	ANILLO GUARDAPOLVO		2	
10	R180269004000	GHIERA DI STERZO	STEERING RING NUT	BAGUE DE DIRECTION	LENKUNGSZAPFEN	ZUNCHO DE DIRECCIÓN		1	
11	R21413171A	GHIERA PERNO DI STERZO	STEERING RING NUT PIN	BAGUE PIVOT DE DIRECTION	LENKUNGSZAPFEN-NUTMUTTER	ZUNCHO PERNO DE DIRECCIÓN		1	
12	R310169008000	BASE DI STERZO	STEERING HEAD BASE	BASE DE DIRECTION	GABELKOPF	TIJA INFERIOR		1	
13	R90752292B	VITE	SCREW	VIS	SCHRAUBE	TORNILLO		2	
14	R90750512B	VITE	SCREW	VIS	SCHRAUBE	TORNILLO		6	
15	R310069006000	ASSIEME GAMBA DX	R.H. FORK LEG ASSEMBLY	ENSEMBLE FOURCHE DROITE	RECHTES FEDERBEIN KOMPLETT	TUBO HORQUILLA DER.		1	
16	R310069005000	ASSIEME GAMBA SX	L.H. FORK LEG ASSEMBLY	ENSEMBLE FOURCHE GAUCHE	LINKES FEDERBEIN KOMPLETT	TUBO HORQUILLA IZQ.		1	
17	R180257138000	PIASTRA SUPPORTO PARAFANGO	MUDGUARD SUPPORT PLATE	PLAQUE DE SUPPORT GARDE-BOUE	HALTEPLATTE FÜR SCHUTZBLECH	PLANCHA SOPORTE GUARDABARROS		2	
18	R90750412B	VITE	SCREW	VIS	SCHRAUBE	TORNILLO		4	
19	R90750532B	VITE	SCREW	VIS	SCHRAUBE	TORNILLO		2	
20	R310069000000	FORCELLA ANTERIORE COMPLETA	COMPLETE FRONT FORK	FOURCHE AVANT COMPLÈTE	KOMPLETTE TELEGABEL	HORQUILLA DELANTERA COMPLETA		1	

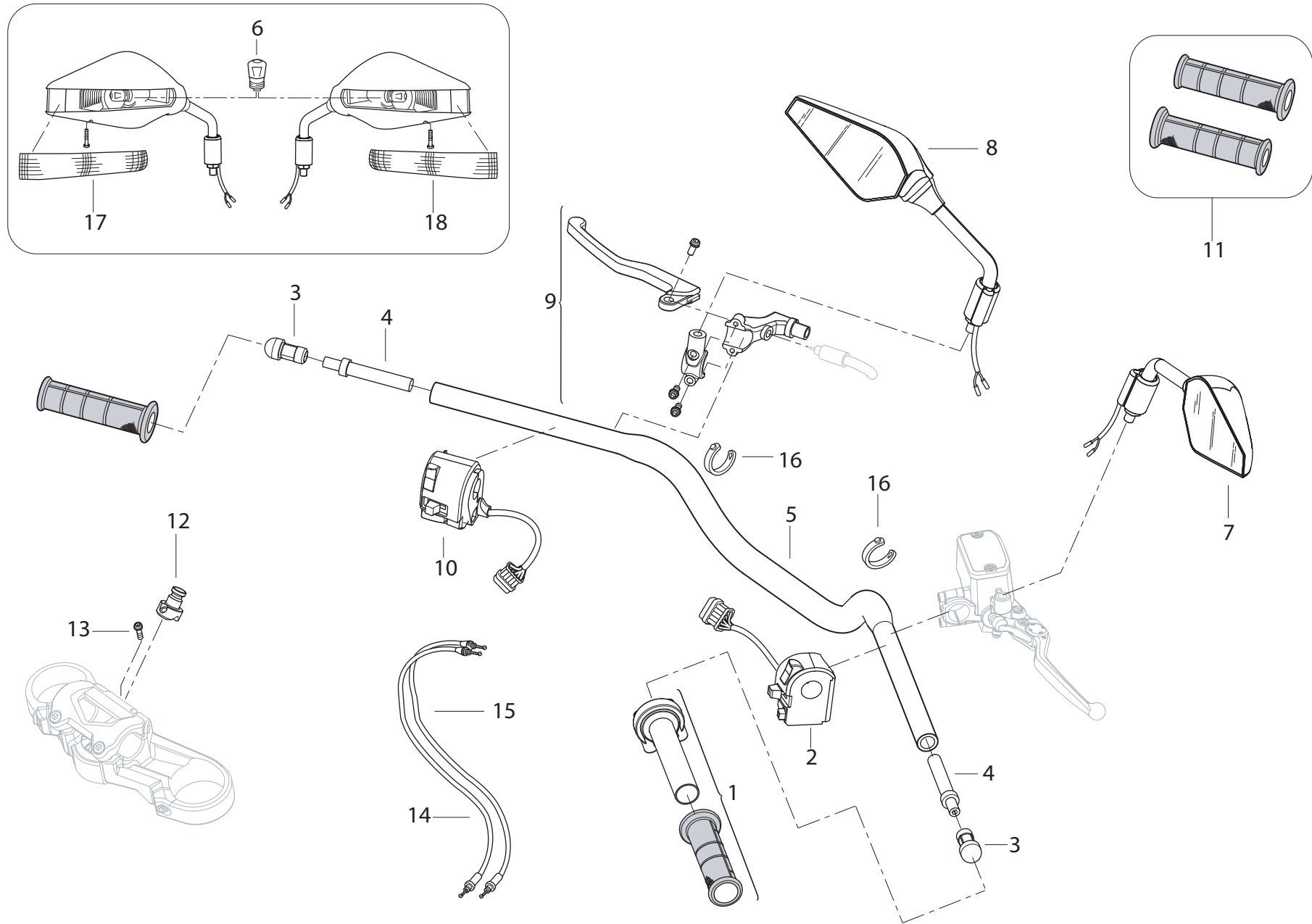

POS. NO. N. INDEX POS.	N. CODICE CODE NO. Nr. CODE ATRIKEL Nr. CODICO Nr.	DESCRIZIONE	DESCRIPTION	DESIGNATION	BEZEICHNUNG	DENOMINACION	NOTE NOTES NOTES MARKE NOTAS	Q.TA' Q.TY Q.TE M.GE C.AD	
1	R21413291A	COMANDO GAS	THROTTLE CONTROL	CONTRÔLE GAZ	GASSTEUERUNG	MANDO ACELERADOR		1	
2	R300062110000	COMMUTATORE DX	R.H. SWITCH	COMMUTATEUR DROIT	RECHTER LENKERSCHALTER	COMMUTADOR DER.		1	
3	R180279170000	TAPPO	CAP	BOUCHON	VERSCHLUB	TAPÓN		2	
4	R300061003000	TERMINALE MANOPOLA	HAND GRIP TERMINAL	TERMINAISON POIGNÉE	ENDSTÜCK GRIFF	TERMINAL PUÑO		2	
5	R310056000000	MANUBRIO	HANDLEBAR	GUIDON	LENKER	MANILLAR		1	
6	R310078006000	LAMPADA	BULB	LAMPE	BIRNE	LÁMPARA		1	
7	R310092000000	SPECCHIO RETROVISORE DX	R.H. REAR-VIEW MIRROR	RÉTROVISEUR DROIT	RECHTER RÜCKSPIEGEL	ESPEJO RETROVISOR DER.		1	
8	R310092001000	SPECCHIO RETROVISORE SX	L.H. REAR-VIEW MIRROR	RÉTROVISEUR GAUCHE	LINKER RÜCKSPIEGEL	ESPEJO RETROVISOR IZQ.		1	
9	R300065002000	LEVA COMANDO FRIZIONE	CLUTCH CONTROL LEVER	LEVIER DE COMMANDE EMRAYAGE	KUPPLUNGSHEBEL	LEVA MANDO EMBRAGUE		1	
10	R300062109000	COMMUTATORE SX	L.H. SWITCH	COMMUTATEUR GAUCHE	LINKER LENKERSCHALTER	COMMUTADOR IZQ.		1	
11	R180200170000	COPPIA MANOPOLE	GRIPS PAIR	JEU DE POIGNÉES	GRIFFPAAR	PAR PUÑOS		1	
12	R310057183000	SUPPORTO GPS	GPS HOLDER	SUPPORT GPS	HALTERUNG GPS	SOPORTE GPS		1	
13	R90750412B	VITE	SCREW	VIS	SCHRAUBE	TORNILLO		1	
14	R310060104000	CAVO APERTURA GAS	THROTTLE OPENING CABLE	CÂBLE OVERTURE GAZ	GASÖFFNUNGSKABEL	CABLE ABERTURA ACELERADOR		1	
15	R310060106000	CAVO CHIUSURA GAS	THROTTLE CLOSING CABLE	CÂBLE FERMETURE GAZ	GASCHLIEßKABEL	CABLE CIERRE ACELERADOR		1	
16	R22640041AZ	FASCETTA IN GOMMA	RUBBER HOSE CLAMP	COLLIER EN CAOUTCHOUC	GUMMISCHELLE	ABRAZADERA EN GOMA		2	
17	R310078004000	COPPETTA DX	R.H. CUP	CUVETTE DROIT	RECHTER WANNE	TULIPA DER.		1	
18	R310078005000	COPPETTA SX	L.H. CUP	CUVETTE GAUCHE	LINKER WANNE	TULIPA IZQ.		1	

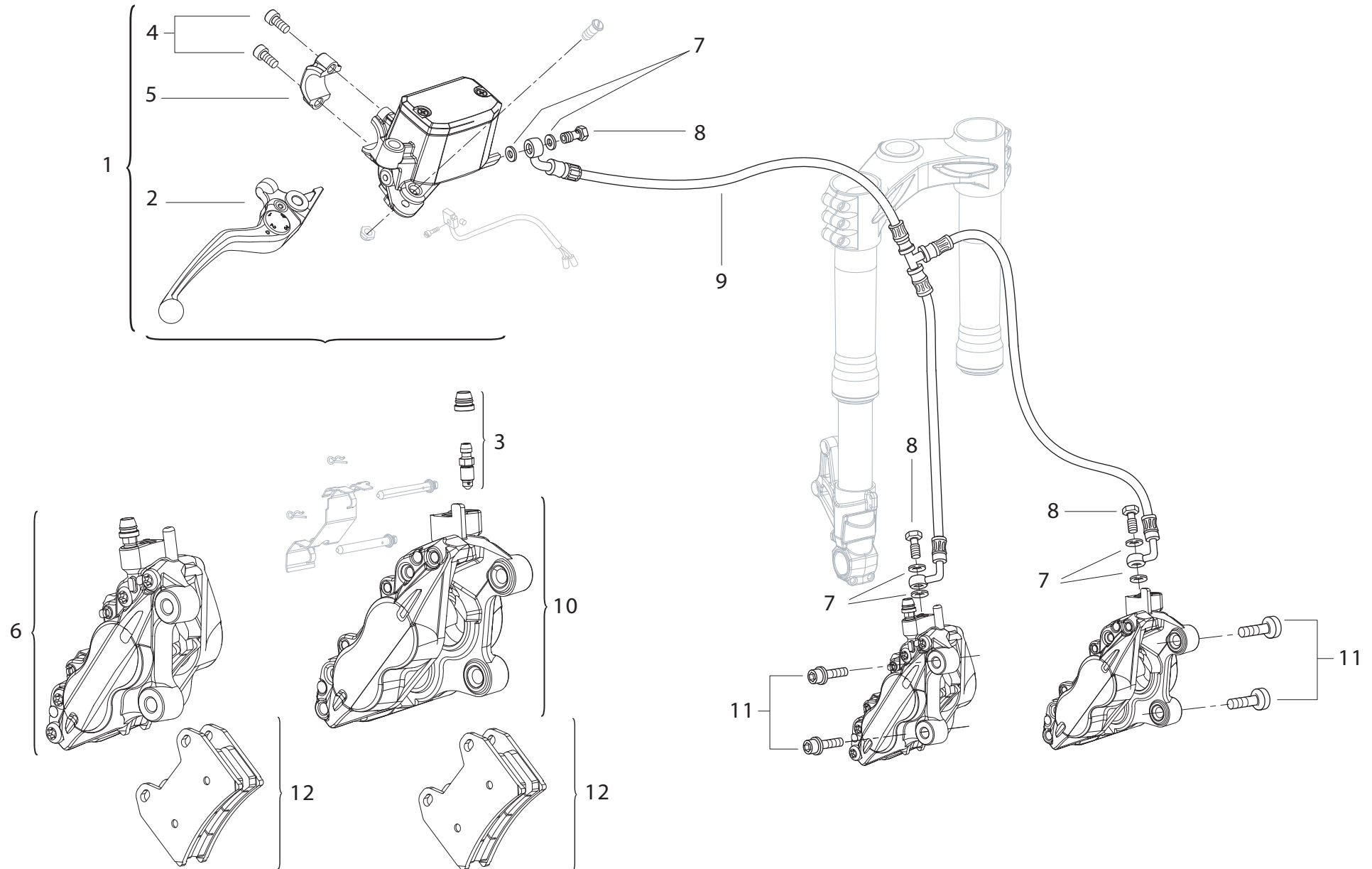

POS. NO. N. INDEX POS.	N. CODICE CODE NO. Nr. CODE ATRIKEL Nr. CODICO Nr.	DESCRIZIONE	DESCRIPTION	DESIGNATION	BEZEICHNUNG	DENOMINACION	NOTE NOTES NOTES MARKE NOTAS	Q.TA' Q.TY Q.TE M.GE C.AD	
1	R300063000000	POMPA FRENO ANTERIORE	FRONT BRAKE PUMP	POMPE FREIN AVANT	PUMPE FÜR VORDERRADBREMSE	BOMBA FRENO DELANTERO		1	
2	R300063104000	LEVA COMANDO FRENO	BRAKE CONTROL LEVER	LEVIER DE COMMANDE FREIN	BREMSHEBEL	LEVA MANDO FRENO		1	
3	R310000186000	SPURGO	BLEED	VIDANGE	ABLAß	PURGA		1	
4	R90750692B	VITE	SCREW	VIS	SCHRAUBE	TORNILLO		2	
5	R300063105000	CAVALLOTTO	BRACKET	CAVALIER	BÜGELBOLZEN	PERNO DE U		1	
6	R300063004000	PINZA FRENO DX	R.H. BRAKE CALIPER	PINCE FREIN DROIT	RECHTE BREMSZANGE	PINZA FRENO DERECHA		1	
7	R180264003000	GUARNIZIONE	GASKET	GARNITURE	DICHTUNG	JUNTA		6	
8	R180264002000	VITE SPECIALE	SPECIAL SCREW	VIS SPÉCIALE	SPEZIALSCHRAUBE	TORNILLO ESPECIAL		3	
9	R310064100000	TUBO FRENO ANTERIORE	FRONT BRAKE LINE	TUBE FREIN AVANT	VORDERE BREMSLEITUNG	TUBO FRENO DELANTERO		1	
10	R300063005000	PINZA FRENO SX	L.H. BRAKE CALIPER	PINCE FREIN GAUCHE	LINKE BREMSZANGE	PINZA FRENO IZQ.		1	
11	R21215231A	VITE	SCREW	VIS	SCHRAUBE	TORNILLO		4	
12	R300000126000	COPPIA PASTIGLIE	PADS PAIR	PAIRE DE PLAQUETTES	PAAR BREMSBELÄGE	PAR PASTILLAS		2	

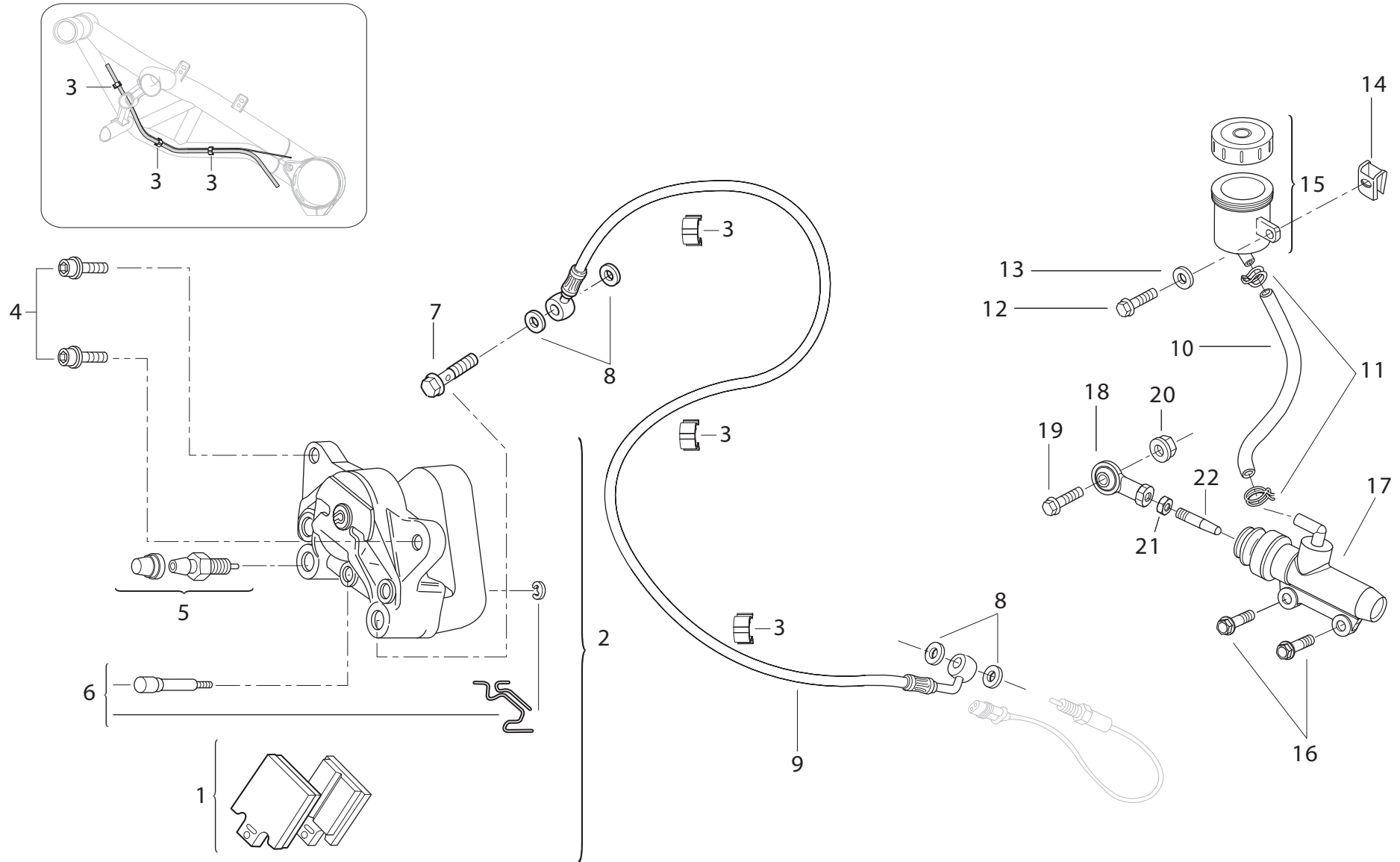



FRENO POSTERIORE



REAR BRAKE



FREIN ARRIÈRE



HINTERBREMSE



FRENO TRASERO

POS. NO. N. INDEX POS.	N. CODICE CODE NO. Nr. CODE ATRIKEL Nr. CODICO Nr.	DESCRIZIONE	DESCRIPTION	DESIGNATION	BEZEICHNUNG	DENOMINACION	NOTE NOTES NOTES MARKE NOTAS	Q.TA' Q.TY Q.TE M.GE C.AD	
1	R310000127000	COPPIA PASTIGLIE	PADS PAIR	PAIRE DE PLAQUETTES	PAAR BREMSBELÄGE	PAR PASTILLAS		1	
2	R310063006000	PINZA FRENO POSTERIORE	REAR BRAKE CALIPER	PINCE FREIN ARRIÈRE	HITERE BREMSZANGE	PINZA FRENO TRASERO		1	
3	R300063124000	PASSACAVO	FAIRLEAD	PASSE-CÂBLE	KABELDURCHFÜHRUNG	PASA-CABLE		3	
4	R90751432B	VITE	SCREW	VIS	SCHRAUBE	TORNILLO		2	
5	R310000186000	SPURGO	BLEED	VIDANGE	ABLAß	PURGA		1	
6	R310000187000	RICAMBIO PERNI E MOLLETTA	SPARE PINS AND SPRING	KIT GOUJONS ET RESSORT	ERSATZTEILE BOLZEN MIT FEDER	RECAMBIOS PERNOS Y RESORTE		1	
7	R180264002000	VITE SPECIALE	SPECIAL SCREW	VIS SPÉCIALE	SPEZIALSCHRAUBE	TORNILLO ESPECIAL		1	
8	R180264003000	GUARNIZIONE	GASKET	GARNITURE	DICHTUNG	JUNTA		4	
9	R310064101000	TUBO FRENO POSTERIORE	REAR BRAKE LINE	TUBE FREIN ARRIÈRE	HINTERE BREMSLEITUNG	TUBO FRENO TRASERO		1	
10	R180164001000	TUBO	TUBE	TUBE	ROHR	TUBO		1	
11	R95251153B	FASCETTA A MOLLA	CLAMP	COLLIER	SHELLE	ABRAZADERA		2	
12	R90750412B	VITE	SCREW	VIS	SCHRAUBE	TORNILLO		1	
13	R300063109000	BOCCOLA	BUSH	DOUILLE	BUCHSE	CASQUILLO		1	
14	R95050082B	CLIP FISSAGGIO RAPIDO	QUIK FASTENING	FIXATION RAPIDE	SCHNELLBEFESTIGUNG	FIJACIÓN RÁPIDA		1	
15	R21413271A	SERBATOIO OLIO COMPLETO	COMPLETE OIL TANK	RÉSERVOIR D' HUILE COMPLET	KOMPLETTER ÖLTANK	DEPÓSITO ACEITE COMPLETO		1	
16	R90750692B	VITE	SCREW	VIS	SCHRAUBE	TORNILLO		2	
17	R310063007000	POMPA FRENO POSTERIORE	REAR BRAKE PUMP	POMPE FREIN ARRIÈRE	PUMPE FÜR HITERRADBREMSE	BOMBA FRENO TRASERO		1	
18	R21813851A	SNODO SFERICO	BALL JOINT	JOINT À ROTULE	KUGELGELENK	ARTICULACIÓN ESFÉRICA		1	
19	R90750512B	VITE	SCREW	VIS	SCHRAUBE	TORNILLO		1	
20	R91750032B	DADO	NUT	ECROU	MUTTER	TUERCA		1	
21	R91551022B	DADO	NUT	ECROU	MUTTER	TUERCA		1	
22	R21215041A	ASTA DI REGISTRO	ADJUSTER ROD	TIGE DE RÉGLAGE	EINSTELLSTAB	VARILLA DE REGULACIÓN		1	

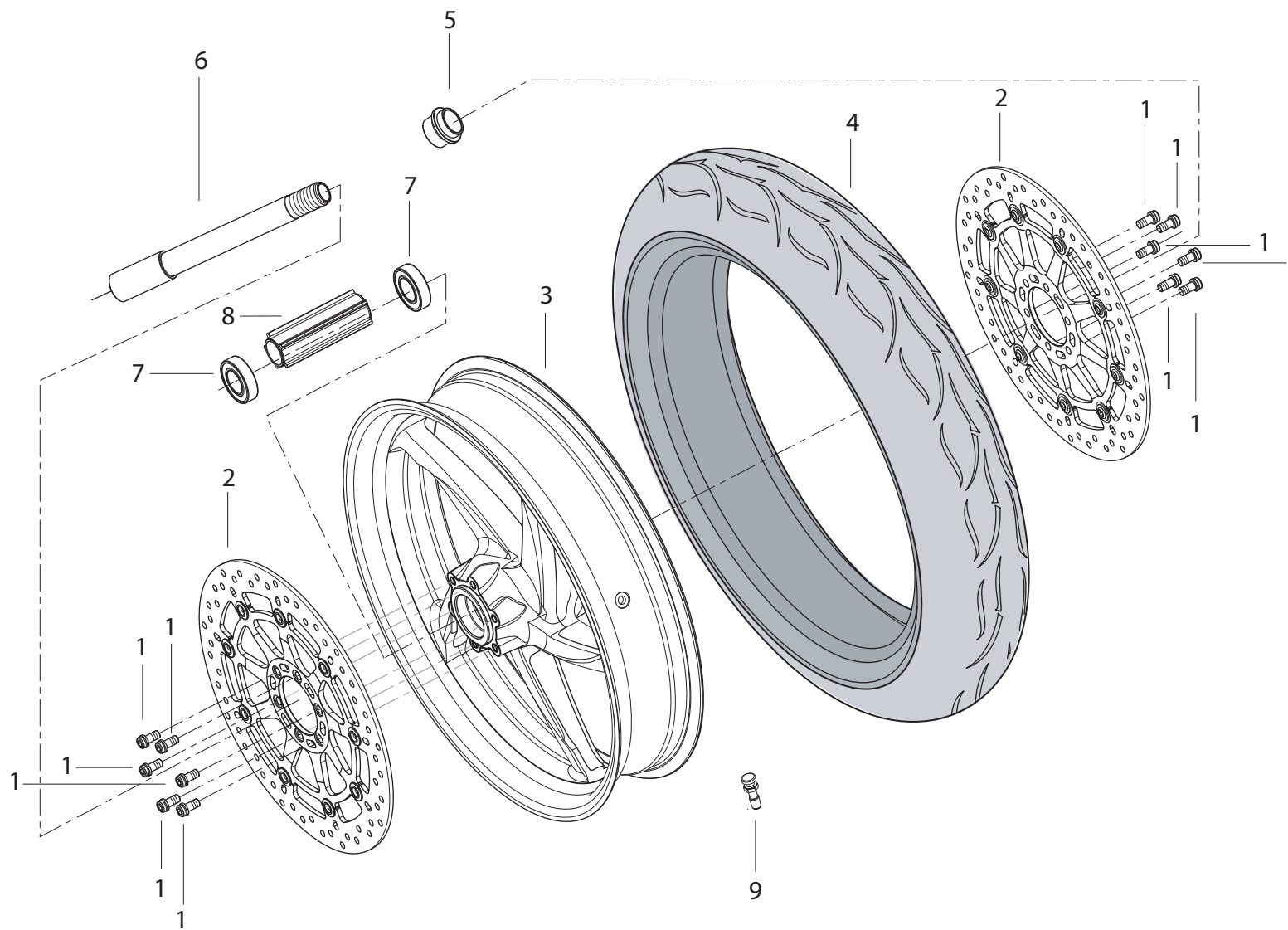

POS. NO. N. INDEX POS.	N. CODICE CODE NO. Nr. CODE ATRIKEL Nr. CODICO Nr.	DESCRIZIONE	DESCRIPTION	DESIGNATION	BEZEICHNUNG	DENOMINACION	NOTE NOTES NOTES MARKE NOTAS	Q.TA' Q.TY Q.TE M.GE C.AD	
1	R90751422B	VITE	SCREW	VIS	SCHRAUBE	TORNILLO		12	
2	R300071101000	DISCO FRENO ANTERIORE (Ø320)	FRONT BRAKE DISC (Ø320)	DISQUE FREIN AVANT (Ø320)	VORDERE BREMSSCHEIBE (Ø320)	DISCO FRENO DELANTERO (Ø320)		2	
3	R30037100200E	CERCHIO RUOTA ANTERIORE (NERO)	FRONT WHEEL RIM (BLACK)	JANTE ROUE AVANT (NOIR)	VORDERRADFELGE (SCHWARZ)	LLANTA RUEDA DELANTERA (NEGRO)		1	
4	R310071100000	PNEUMATICO ANTERIOIRE	FRONT TIRE	PNEU AVANT	VORDES REIFEN	NEUMÁTICO DELANTERO		1	
5	R180271116000	DISTANZIALE SINISTRO	L.H. SPACER	ENTRETOISE GAUCHE	LINKES DISTANZSTÜCK	DISTANCIADOR IZQ.		1	
6	R180471107000	PERNO RUOTA ANTERIORE	FRONT WHEEL SPINDLE	PIVOT ROUE AV.	VORDERRADZAPFEN	PERNO RUEDA DELANTERA		1	
7	R21215201A	CUSCINETTO	BEARING	ROULEMENT	LAGER	COJINETE		2	
8	R180271104000	DISTANZIALE INTERNO	INNER SPACER	ENTRETOISE INTERNE	INNERES DISTANZSTÜCK	DISTANCIADOR INTERIOR		1	
9	R180272108000	VALVOLA	VALVE	SOUPAPE	VENTIL	VÁLVULA		1	



RUOTA POSTERIORE



REAR WHEEL



ROUE ARRIÈRE



HINTERRAD



RUEDA TRASERA

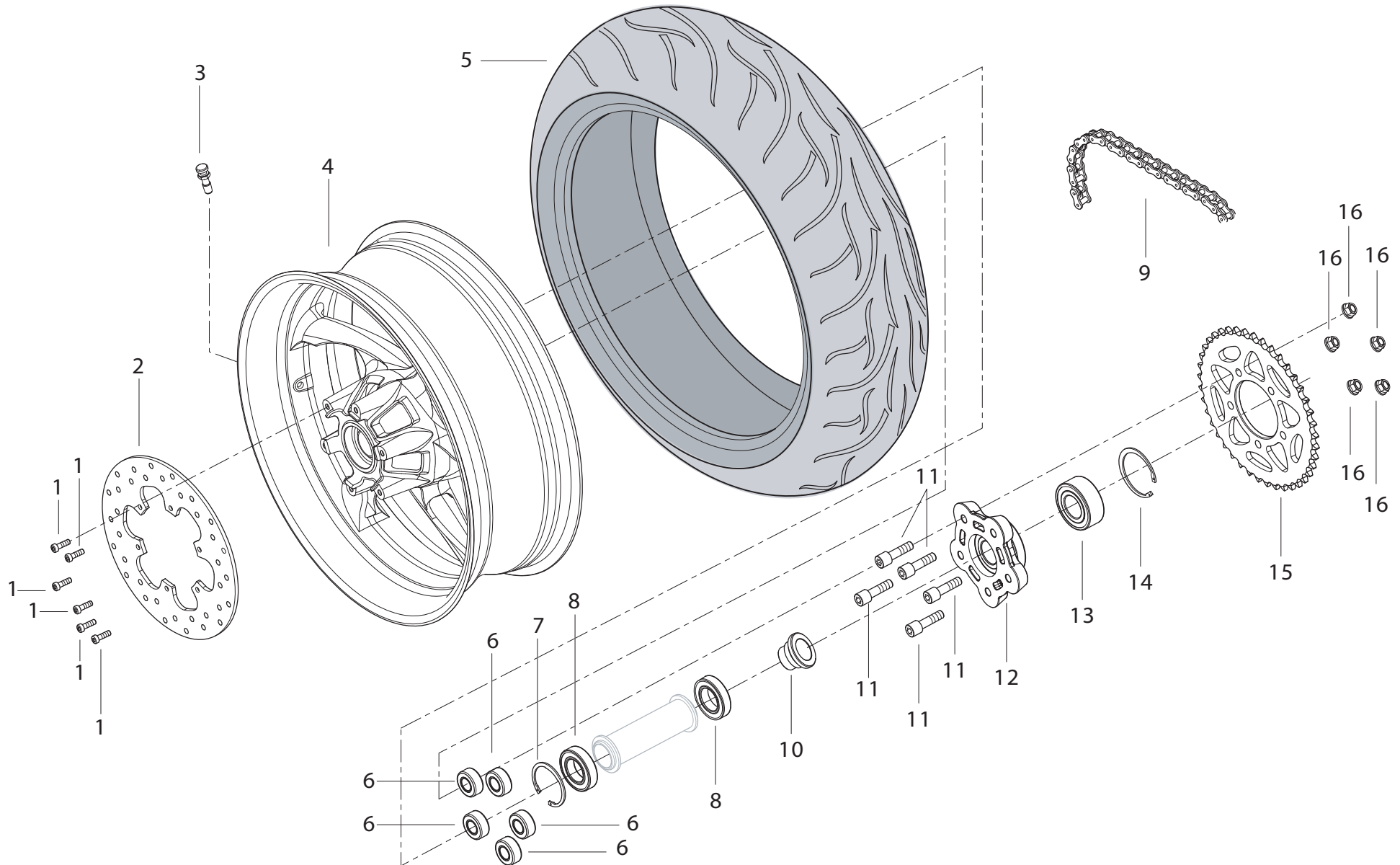

POS. NO. N. INDEX POS.	N. CODICE CODE NO. Nr. CODE ATRIKEL Nr. CODICO Nr.	DESCRIZIONE	DESCRIPTION	DESIGNATION	BEZEICHNUNG	DENOMINACION	NOTE NOTES NOTES MARKE NOTAS	Q.TA' Q.TY Q.TE M.GE C.AD	
1	R90350672C	VITE	SCREW	VIS	SCHRAUBE	TORNILLO		6	
2	R180272105000	DISCO FRENO POSTERIORE	REAR BRAKE DISC	DISQUE FREIN AR.	HINTERE BREMSSCHEIBE	DISCO FRENO TRASERO		1	
3	R180272108000	VALVOLA	VALVE	SOUPAPE	VENTIL	VÁLVULA		1	
4	R30037200200E	CERCHIO RUOTA POSTERIORE (NERO)	REAR WHEEL RIM (BLACK)	JANTE ROUE AR. (NOIR)	HINTERRADFELGE (SCHWARZ)	LLANTA RUEDA TRASERA (NEGRO)		1	
5	R310072100000	PNEUMATICO POSTERIORE	REAR TIRE	PNEU ARRIÈRE	HINTER REIFEN	NEUMÁTICO TRASERO		1	
6	R180272109000	GOMMA PARASTRAPPI	SPRING DRIVE RUBBER	CAOUTCHOUC FLECTEUR	STOESSSCHUTZGUMMI	GOMA JUNTA AMORTIGÜADORA		5	
7	R21214961A	ANELLO ELASTICO	SNAP RING	BAGUE ÉLASTIQUE	SPRENGRING	SEAGER		1	
8	R21214921A	CUSCINETTO	BEARING	ROULEMENT	LAGER	COJINETE		2	
9	R310027001000	CATENA	CHAIN	CHAÎNE	KETTE	CADENA		1	
10	R180272117000	DISTANZIALE SINISTRO	L.H. SPACER	ENTRETOISE GAUCHE	LINKES DISTANZSTÜCK	DISTANCIADOR IZQ.		1	
11	R180272113000	VITE	SCREW	VIS	SCHRAUBE	TORNILLO		5	
12	R180272104000	FLANGIA PORTACORONA	REAR SPROCKET FLANGE	BRIDE PORTE-COURONNE	KRANZHALTEFLANSCH	BRIDA PORTA-CORONA		1	
13	R180172114000	CUSCINETTO	BEARING	ROULEMENT	LAGER	COJINETE		1	
14	R92652620D	ANELLO ELASTICO	SNAP RING	BAGUE ÉLASTIQUE	SPRENGRING	SEAGER		1	
15	R310027031000	CORONA Z34	RING GEAR Z34	COURONNE Z34	KRANZ Z34	CORONA Z34		1	
16	R91350092B	DADO	NUT	ECROU	MUTTER	TUERCA		5	

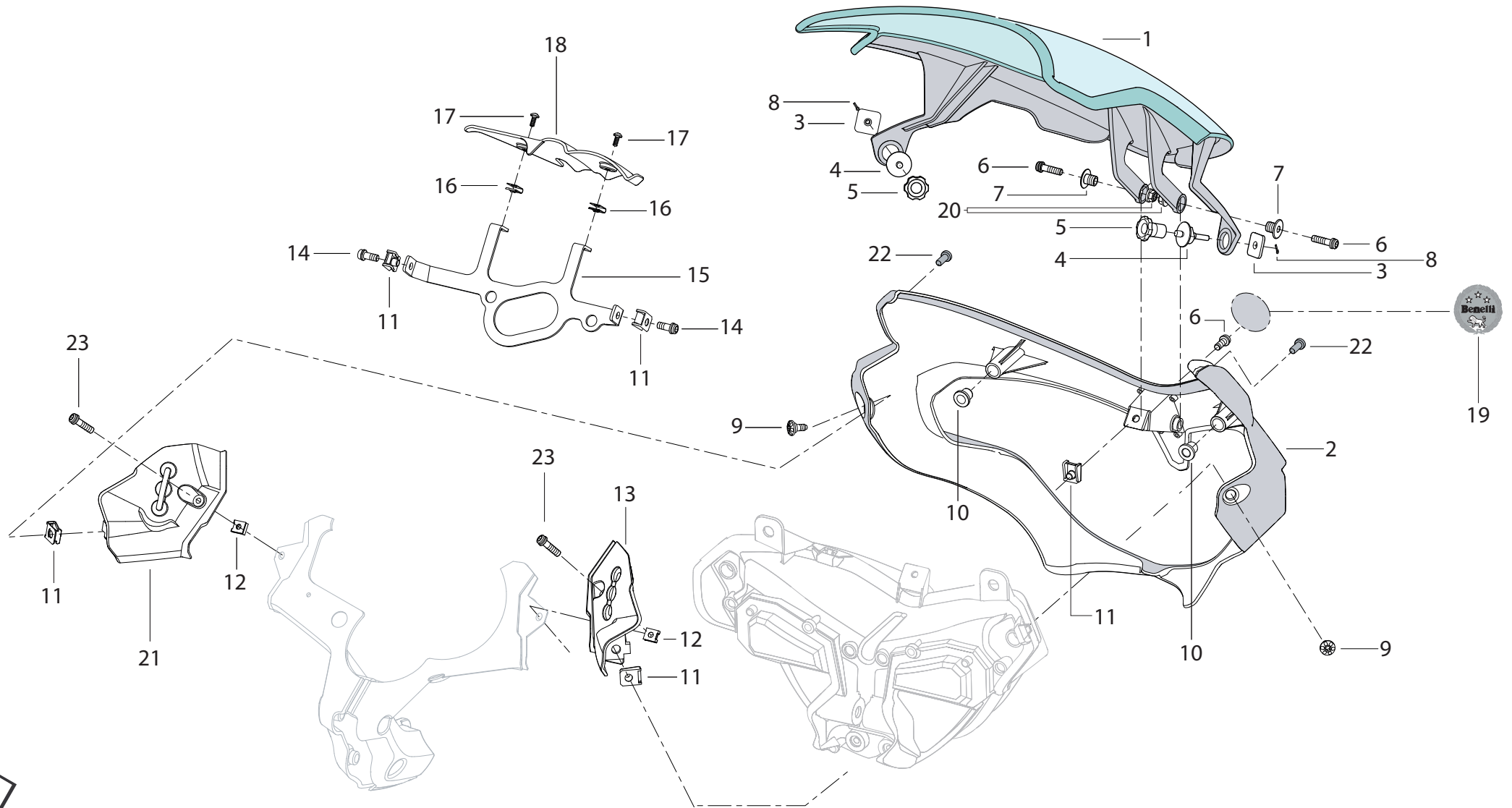

POS. NO. INDEX POS.	N. CODICE CODE NO. Nr. CODE ATRIKEL Nr. CODICO Nr.	DESCRIZIONE	DESCRIPTION	DESIGNATION	BEZEICHNUNG	DENOMINACION	NOTE NOTES NOTES MARKE NOTAS	Q.TA' Q.TY Q.TE M.GE C.AD	
1	R310000185000	KIT CUPOLINO	HEADLIGHT FAIRING KIT	KIT CARÉPAGE	KIT FAHRTWINDSCHUTZ	KIT CÚPULA		1	
2	R3100961000CL	CUPOLINO FISSO (NERO DARK)	FIXED HEADLIGHT FAIRING (BLACK DARK)	BULLE FIXE (NOIR DARK)	FESTSTEHENDE COCKPITVERKLEIDUNG (SCHWARZ DARK)	CÚPULA FIJA (NEGRO DARK)		1	
2	R3100961000CW	CUPOLINO FISSO (ARGENTO)	FIXED HEADLIGHT FAIRING (SILVER)	BULLE FIXE (ARGENT)	FESTSTEHENDE COCKPITVERKLEIDUNG (SILBERN)	CÚPULA FIJA (PLATA)		1	
3	R310057167000	PIASTRINO	PLATE	PLAQUETTE	PLÄTTCHEN	LÁMINA		2	
4	R310057166000	PERNO	PIN	PIVOT	ZAPFEN	PERNO		2	
5	R310057168000	POMELLO	KNURL	MOLETAGE	KNURL	NUDO		2	
6	R90750422B	VITE	SCREW	VIS	SCHRAUBE	TORNILLO		3	
7	R310079001000	BOCCOLA	BUSH	DOUILLE	BUCHSE	CASQUILLO		2	
8	R92350102B	COPIGLIA	SPLIT PIN	GOUPILLE	SPLINT	CLAVIJA		2	
9	R90752268E	VITE SPECIALE	SPECIAL SCREW	VIS SPÉCIALE	SPEZIALSCHRAUBE	TORNILLO ESPECIAL		2	
10	R310079203000	ANTIVIBRANTE	VIBRATION DAMPER	ANTIVIBRATION	SCHWINGUNGSDÄMPFER	ANTI-VIBRACIÓN		2	
11	R95050012A	CLIP FISSAGGIO RAPIDO	QUIK FASTENING	FIXATION RAPIDE	SCHNELLEBEFESTIGUNG	FIJACIÓN RÁPIDA		5	
12	R95050052A	CLIP FISSAGGIO RAPIDO	QUIK FASTENING	FIXATION RAPIDE	SCHNELLEBEFESTIGUNG	FIJACIÓN RÁPIDA		2	
13	R310074188000	COPERCHIO FARO DX	R.H. COVER	COUVERCLE DROIT	DECKEL RECHTER	TAPA DER.		1	
14	R90750492B	VITE	SCREW	VIS	SCHRAUBE	TORNILLO		2	
15	R310080001000	PIASTRINO	PLATE	PLAQUETTE	PLÄTTCHEN	LÁMINA		1	
16	R95050102B	CLIP FISSAGGIO RAPIDO	QUIK FASTENING	FIXATION RAPIDE	SCHNELLEBEFESTIGUNG	FIJACIÓN RÁPIDA		2	
17	R93054019L	VITE	SCREW	VIS	SCHRAUBE	TORNILLO		2	
18	R310074239000	COPERCHIO CONNETTORI	COVER	COUVERCLE	DECKEL	TAPA		1	
19	R030493003000	DECALCOMANIA "BENELLI" ø 40	STICKER "BENELLI" ø 40	DÉCALCOMANIE "BENELLI" ø 40	AUFKLEBER "BENELLI" ø 40	ADHESIVO "BENELLI" ø 40		1	
20	R91350062B	DADO	NUT	ECROU	MUTTER	TUERCA		2	
21	R310074189000	COPERCHIO FARO SX	L.H. COVER	COUVERCLE GAUCHE	DECKEL LINKS	TAPA IZQ.		1	
22	R180190121000	TAPPO	CAP	BOUCHON	VERSCHLUß	TAPÓN		2	
23	R93650029E	VITE	SCREW	VIS	SCHRAUBE	TORNILLO		2	

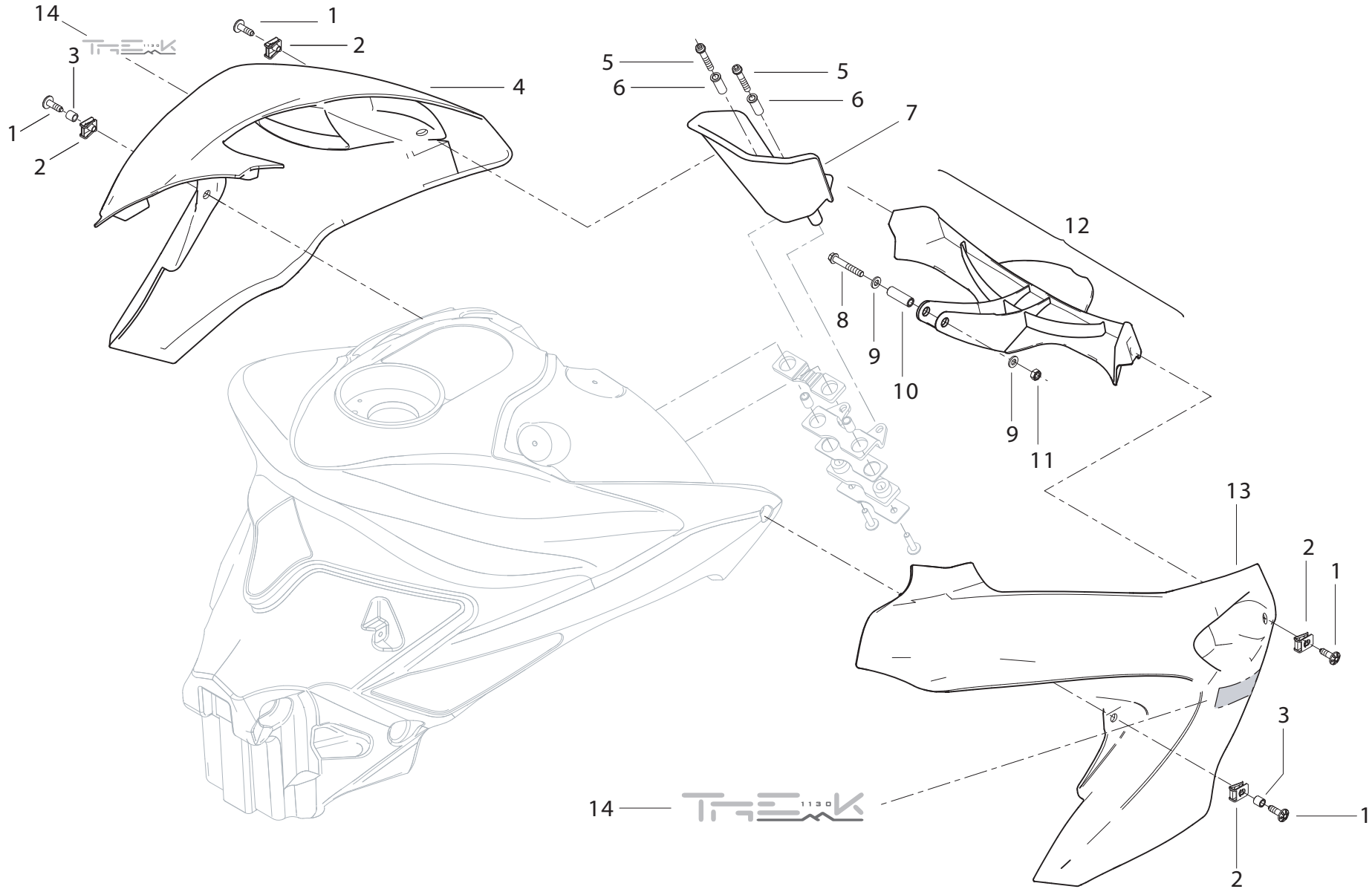

POS. NO. N. INDEX POS.	N. CODICE CODE NO. Nr. CODE ATRIKEL Nr. CODICO Nr.	DESCRIZIONE	DESCRIPTION	DESIGNATION	BEZEICHNUNG	DENOMINACION	NOTE NOTES NOTES MARKE NOTAS	Q.TA' Q.TY Q.TE M.GE C.AD	
1	R90752181A	VITE SPECIALE	SPECIAL SCREW	VIS SPÉCIALE	SPEZIALSCHRAUBE	TORNILLO ESPECIAL		4	
2	R95050012A	CLIP FISSAGGIO RAPIDO	QUIK FASTENING	FIXATION RAPIDE	SCHNELLEBEFESTIGUNG	FIJACIÓN RÁPIDA		4	
3	R310057001000	BOCCOLA	BUSH	DOUILLE	BUCHSE	CASQUILLO		2	
4	R3100741830CL	FIANCHETTO SX (NERO DARK)	L.H. BODY PANEL (BLACK DARK)	PANNEAU LATÉRAL GAUCHE (NOIR DARK)	LINK SEITENABDECKUNG (SCHWARZ DARK)	PANEL IZQ. (NEGRO DARK)		1	
4	R3100741830CX	FIANCHETTO SX (ARGENTO)	L.H. BODY PANEL (SILVER)	PANNEAU LATÉRAL GAUCHE (ARGENT)	LINK SEITENABDECKUNG (SILBERN)	PANEL IZQ. (PLATA)		1	
5	R90750542B	VITE	SCREW	VIS	SCHRAUBE	TORNILLO		2	
6	R310079184000	BOCCOLA	BUSH	DOUILLE	BUCHSE	CASQUILLO		2	
7	R310074191000	COPERCHIO BLOCCASTERZO	STEERING LOCK COVER	COUVERCLE BLOQUE DIRECTION	DECKEL LENKSPERRE	TAPA BLOQUE EMBRAGUE		1	
8	R90750732B	VITE	SCREW	VIS	SCHRAUBE	TORNILLO		1	
9	R92050152B	RONDELLA	WASHER	RONDELLE	UNTERLEGSSCHEIBE	ARANDELA		2	
10	R310057002000	BOCCOLA	BUSH	DOUILLE	BUCHSE	CASQUILLO		1	
11	R91750032B	DADO	NUT	ECROU	MUTTER	TUERCA		1	
12	R310074141000	STAFFA	BRACKET	BRIDE	BÜGEL	SOPORTE		1	
13	R3100741820CL	FIANCHETTO DX (NERO DARK)	R.H. BODY PANEL (BLACK DARK)	PANNEAU LATÉRAL DROIT (NOIR DARK)	RECHT SEITENABDECKUNG (SCHWARZ DARK)	PANEL DER. (NEGRO DARK)		1	
13	R3100741820CX	FIANCHETTO DX (ARGENTO)	R.H. BODY PANEL (SILVER)	PANNEAU LATÉRAL DROIT (ARGENT)	RECHT SEITENABDECKUNG (SILBERN)	PANEL DER. (PLATA)		1	
14	R310093001000	KIT ADESIVI	KIT STIKER	KIT DÉCALCOMANIE	KIT AUFKLEBER	KIT ADHESIVOS		2	



SERBATOIO



FUEL TANK



RÉSEVOIR CARBURANT



KRAFTSTOFFTANK



DEPÓSITO GASOLINA

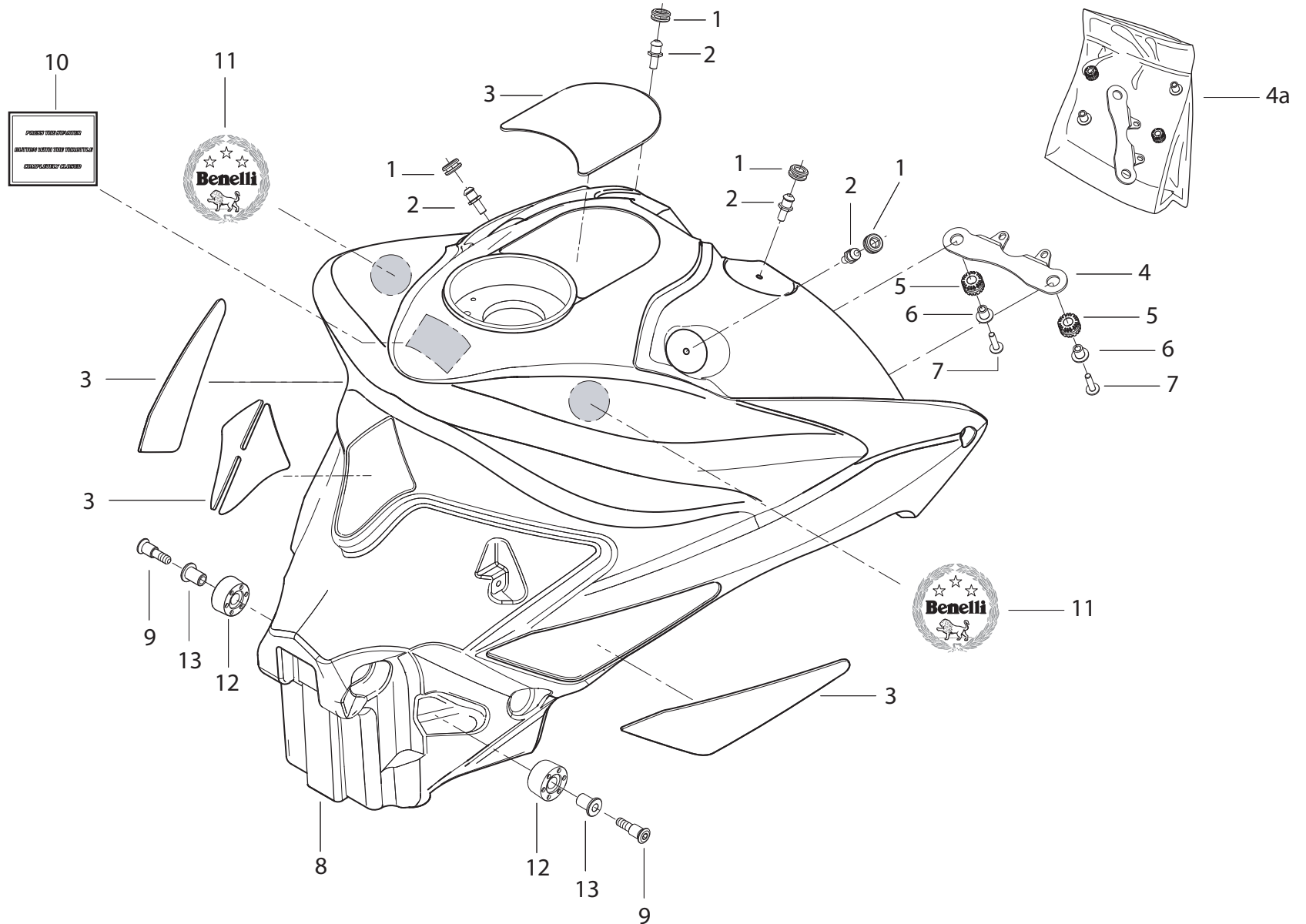

POS. NO. N. INDEX POS.	N. CODICE CODE NO. Nr. CODE ATRIKEL Nr. CODICO Nr.	DESCRIZIONE	DESCRIPTION	DESIGNATION	BEZEICHNUNG	DENOMINACION	NOTE NOTES NOTES MARKE NOTAS	Q.TA' Q.TY Q.TE M.GE C.AD	
1	R100279118000	GOMMINO	RUBBER PAD	JOINT EN CAOUTCHOUC	GUMMISTÜCK	JUNTA DE GOMA		4	
2	R300052003000	VITE SPECIALE	SPECIAL SCREW	VIS SPÉCIALE	SPEZIALSCHRAUBE	TORNILLO ESPECIAL		4	
3	R310093000000	KIT DECALCOMANIE (SERBATOIO)	STICKER KIT (FUEL TANK)	KIT DÉCALCOMANIE (RÉSEVOIR CARBURANT)	KIT AUFKLEBER (KRAFTSTOFFTANK)	KIT ADHESIVO (DEPÓSITO GASOLINA)		4	
4	R310057140001	PIASTRINO	PLATE	PLAQUETTE	PLÄTTCHEN	LÁMINA	dal telaio ZBNTK00007P100490	1	
4a	R310000203000	KIT FISSAGGIO SERBATOIO	FUEL TANK FIXING KIT	KIT FIXATION RÉSEVOIR CARBURANT	KIT BEFESTIGUNG KRAFTSTOFFTANK	KIT FIJACIÓN DEPÓSITO GASOLINA	da ZBNTK00007P100005 a ZBNTK00007P100109	1	
5	R180479181000	GOMMINO	RUBBER PAD	JOINT EN CAOUTCHOUC	GUMMISTÜCK	JUNTA DE GOMA		2	
6	R310057040000	BUSSOLA	BUSH	DOUILLE	BUCHSE	CASQUILLO		2	
7	R90752172B	VITE	SCREW	VIS	SCHRAUBE	TORNILLO		2	
8	R3100881001BT	SERBATOIO (GRIGIO)	FUEL TANK (GREY)	RÉSEVOIR CARBURANT (GRIS)	KRAFTSTOFFTANK (GRAU)	DEPÓSITO GASOLINA (GRIS)		1	
8	R3100881000CW	SERBATOIO (VERDE)	FUEL TANK (GREEN)	RÉSEVOIR CARBURANT (VERT)	KRAFTSTOFFTANK (GRÜN)	DEPÓSITO GASOLINA (VERDE)		1	
8	R3100881000CY	SERBATOIO (GIALLLO)	FUEL TANK (YELLOW)	RÉSEVOIR CARBURANT (JAUNE)	KRAFTSTOFFTANK (GELB)	DEPÓSITO GASOLINA (AMARILLO)		1	
9	R90752882B	VITE SPECIALE	SPECIAL SCREW	VIS SPÉCIALE	SPEZIALSCHRAUBE	TORNILLO ESPECIAL		2	
10	R180293115000	ADESIVO (OMOLOGAZIONE)	STIKER	DÉCALCOMANIE	AUFKLEBER	ADHESIVO		1	
11	R050393002000	DECALCOMANIA "BENELLI"	STICKER "BENELLI"	DÉCALCOMANIE "BENELLI"	AUFKLEBER "BENELLI"	ADHESIVO "BENELLI"		2	
12	R300079181000	TAMPONE IN GOMMA	RUBBER PAD	TAMPON EN CAOUTCHOUC	GUMMISTOPFEN	APOYO DE GOMA		2	
13	R300079182000	BOCCOLA	BUSH	DOUILLE	BUCHSE	CASQUILLO		2	

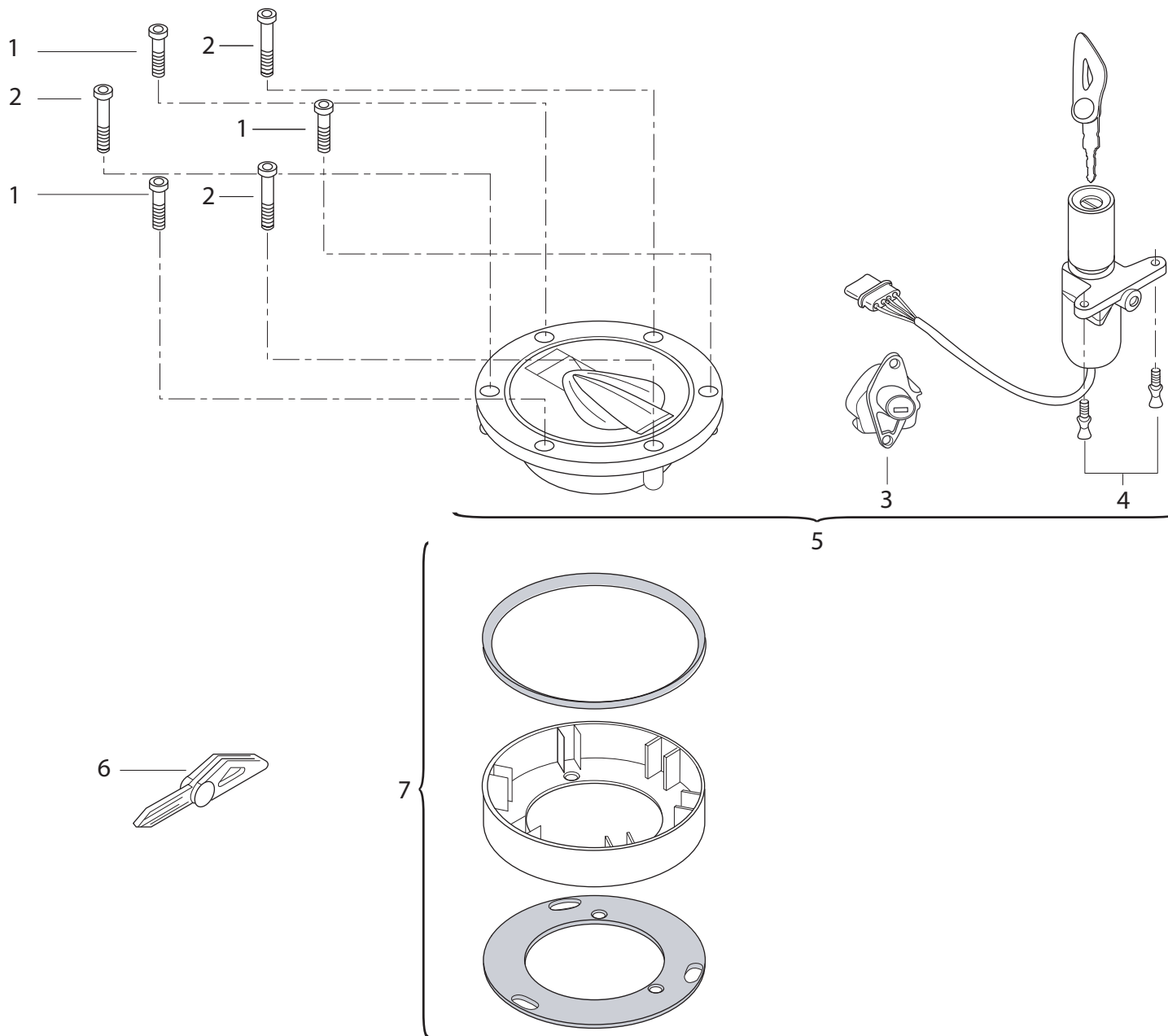

POS. NO. N. INDEX POS.	N. CODICE CODE NO. Nr. CODE ATRIKEL Nr. CODICO Nr.	DESCRIZIONE	DESCRIPTION	DESIGNATION	BEZEICHNUNG	DENOMINACION	NOTE NOTES MARKE NOTAS	Q.TA' Q.TY Q.TE M.GE C.AD	
1	R90250478E	VITE	SCREW	VIS	SCHRAUBE	TORNILLO		3	
2	R90250408E	VITE	SCREW	VIS	SCHRAUBE	TORNILLO		3	
3	R180266126000	SERRATURA SELLA	SEAT LOCK	SERRURE SELLE	SATTELSCHLOß	CERRADURA SILLÍN		1	
4	R180166008000	VITE	SCREW	VIS	SCHRAUBE	TORNILLO		4	
5	R310066002000	GRUPPO SERRATURE	LOCKS KIT	JEU SERRURE	SCHLOßGRUPPE	GRUPO CERRADURAS		1	
6	R180266128000	CHIAVE	WRENCH	CLÈ	SCHLUSSEL	LLAVE		1	
7	R180166125000	GUARNIZIONE	GASKET	GARNITURE	DICHTUNG	JUNTA		1	



PROTEZIONE MOTORE



ENGINE PROTECTION



PROTECTION MOTEUR



SCHUTZ MOTOR



PROTECCIÓN MOTOR

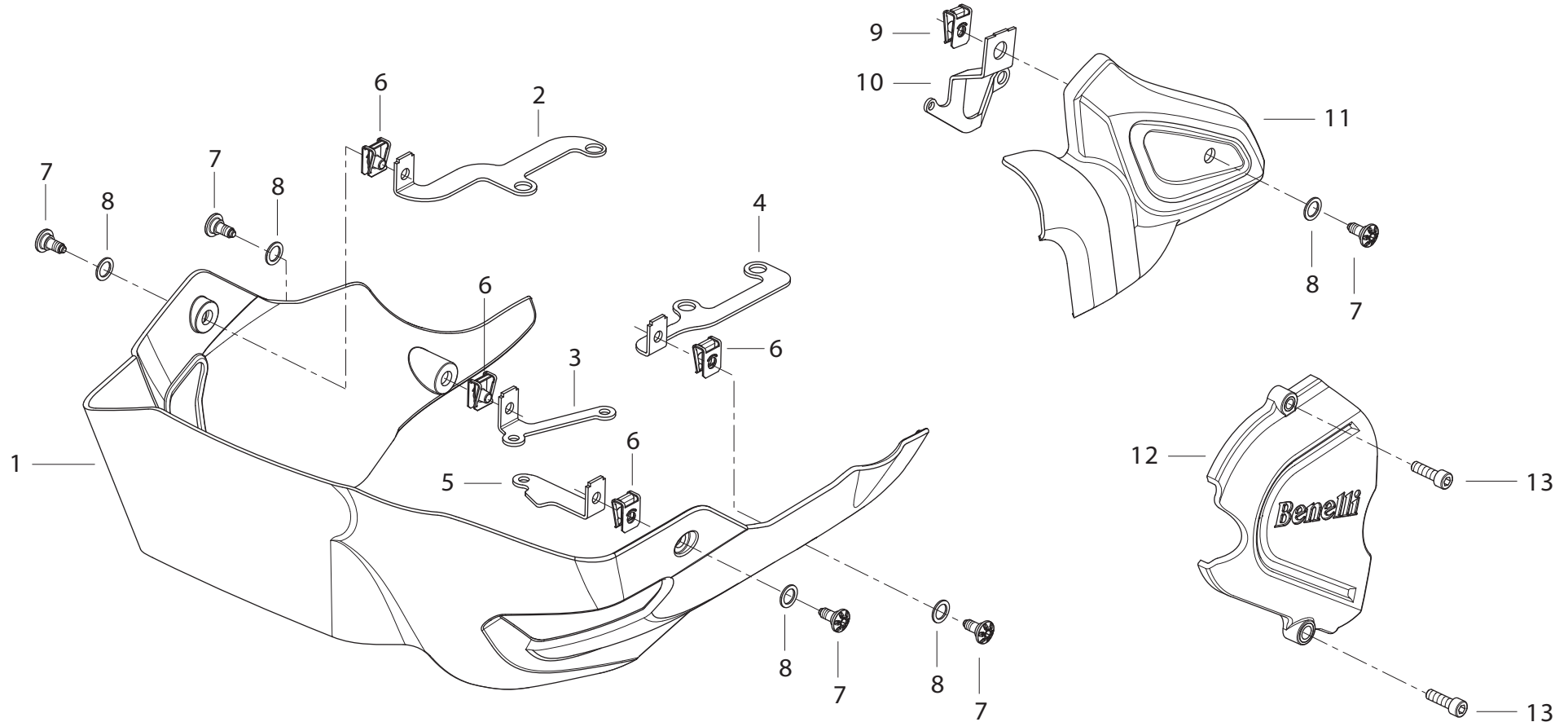



PROTEZIONE MOTORE



ENGINE PROTECTION



PROTECTION MOTEUR



SCHUTZ MOTOR



PROTECCIÓN MOTOR

POS. NO. N. INDEX POS.	N. CODICE CODE NO. Nr. CODE ATRIKEL Nr. CODICO Nr.	DESCRIZIONE	DESCRIPTION	DESIGNATION	BEZEICHNUNG	DENOMINACION	NOTE NOTES NOTES MARKE NOTAS	Q.TA' Q.TY Q.TE M.GE C.AD	
1	R310074138000	PROTEZIONE MOTORE	ENGINE PROTECTION	PROTECTION MOTEUR	SCHUTZ MOTOR	PROTECCIÓN MOTOR		1	
2	R310057164000	PIASTRINO ANTERIORE DX	R.H. FRONT PLATE	PLAQUETTE AVANT DROIT	VORDERE RECHTE PLÄTTCHEN	LÁMINA DELANTERA DER.		1	
3	R310057165000	PIASTRINO POSTERIORE DX	R.H. REAR PLATE	PLAQUETTE ARRIÈRE DROIT	HINTERE RECHTE PLÄTTCHEN	LÁMINA TRASERA DER.		1	
4	R310057162000	PIASTRINO ANTERIORE SX	L.H. FRONT PLATE	PLAQUETTE AVANT GAUCHE	VORDERE LINKE PLÄTTCHEN	LÁMINA DELANTERA IZQ.		1	
5	R310057163000	PIASTRINO POSTERIORE SX	L.H. REAR PLATE	PLAQUETTE ARRIÈRE GAUCHE	HINTERE LINKE PLÄTTCHEN	LÁMINA TRASERA IZQ.		1	
6	R95050012A	CLIP FISSAGGIO RAPIDO	QUIK FASTENING	FIXATION RAPIDE	SCHNELLEBEFESTIGUNG	FIJACIÓN RÁPIDA		4	
7	R90752268E	VITE	SCREW	VIS	SCHRAUBE	TORNILLO		5	
8	R90752302B	RONDELLA NYLON	NYLON WASHER	ROSETTE EN NYLON	NYLON-UNTERLEGSSCHEIBE	ARANDELA NYLON		5	
9	R95050012A	CLIP FISSAGGIO RAPIDO	QUIK FASTENING	FIXATION RAPIDE	SCHNELLEBEFESTIGUNG	FIJACIÓN RÁPIDA		1	
10	R300157166000	PIASTRINO	PLATE	PLAQUETTE	PLÄTTCHEN	LÁMINA		1	
11	R310074221000	COPERCHIO ALTERNATORE	GENERATOR COVER	COUVERCLE ALTERNATEUR	DECKEL DES DREHSTROMGENERATORS	TAPA ALTERNADOR		1	
12	R180201009000	COPERCHIO PIGNONE	SPROCKET COVER	COUVERCLE PIGNON	DECKEL RITZEL	TAPA PIÑÓN		1	
13	R90250672B	VITE	SCREW	VIS	SCHRAUBE	TORNILLO		2	

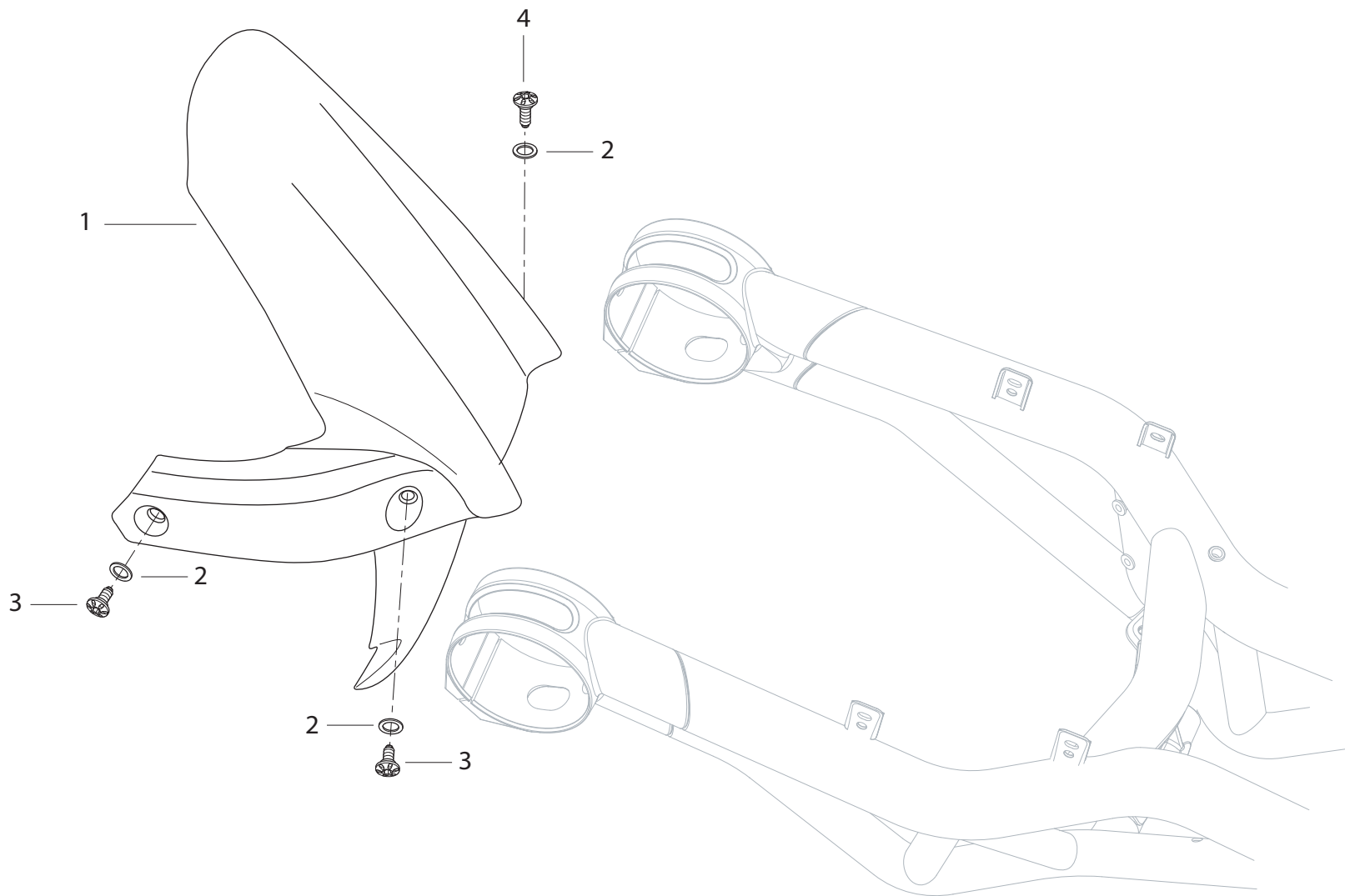

POS. NO. N. INDEX POS.	N. CODICE CODE NO. Nr. CODE ATRIKEL Nr. CODICO Nr.	DESCRIZIONE	DESCRIPTION	DESIGNATION	BEZEICHNUNG	DENOMINACION	NOTE NOTES NOTES MARKE NOTAS	Q.TA' Q.TY Q.TE M.GE C.AD	
1	R3000741710CL	PARAFANGO POSTERIORE	REAR MUDGUARD	GARDE-BOUE ARRIÈRE	HINTERE SCHUTZBLECH	GUARDABARROS TRASERO		1	
2	R90752302B	RONDELLA	WASHER	RONDELLE	UNTERLEGSCHIEBE	ARANDELA		3	
3	R90752268E	VITE	SCREW	VIS	SCHRAUBE	TORNILLO		2	
4	R90750708E	VITE	SCREW	VIS	SCHRAUBE	TORNILLO		1	



IL PRESENTE MANUALE È PROPRIETÀ DELLA
BENELLI Q.J. S.R.L.
OGNI PRODUZIONE, TOTALE O PARZIALE,
È VIETATA.

THIS MANUAL IS PROPERTY OF
BENELLI Q.J. S.R.L.
ANY TOTAL OR PARTIAL REPRODUCTION
IS FORBIDDEN.

CE MANUEL EST DE LA PROPRIÉTÉ DE
BENELLI Q.J. S.R.L.
TOURE REPRODUCTION TOTALE OU
PARTIELLE, ESTINTERDITE.

DIE VORLIEGENDE BEDIENUNGSANLEITUNG
STEHT IM EIGENTUM VON BENELLI Q.J. S.R.L.
JEDE VÖLLIGE ODERTEILWEISE KOPIE
IST VERBOTEN.

EL PRESENTE MANUAL ES PROPIEDAD
DE BENELLI Q.J. S.R.L.
SE PROHÍBE SU REPRODUCCIÓN
TOTAL O PARCIAL.



Benelli consiglia accessori originali
Benelli suggestions original accessories
Benelli conseiller accessoires original
Benelli raten Zubehör originell
Benelli aconsejar accesorios originales



Ver. 02 - Feb. 08
Benelli Q.J. s.r.l.
Strada della Fornace Vecchia
61100 - Pesaro - Italy
www.benelli.com

